

Type: Rectangular Stone Hearth Oven

Model: REC1250

The Beech REC1250 Stone Hearth Oven is manufactured from a high grade castable ceramic material and completely enclosed in a housing of 5mm (1/4") mild steel. This mild steel outer casing and incorporated lifting hooks make installation easy which reduces potential damage to the oven. The inside measurements of the oven are 1250mm (49") x 850mm (33.5") with a 1.06m² (10.8ft²) cooking surface. This style of oven can be fired using wood, gas back-up or full gas.

The spectacular performance of a Beech Oven is a result of the huge thermal mass of the unique ceramic cast interior. Beech Ovens have **TWICE** the mass (*thermal mass*) of any other pre-cast oven on the market. The unique oven design results in superior cooking performance and exceptional thermal efficiency.

The cooking surface of the oven (*stone hearth*) is constructed using high quality 75mm (3") thick Fire bricks, renowned for their excellent cooking attributes and incredible wear resistance. The use of bricks eliminates the unsightly cracking associated with one piece floors. The bricks sit upon a 25mm (1") VF insulating board and a further 5mm (1/4") reinforced mild steel base.

The unique three (3) piece oven design allows all Beech Ovens to be installed through a standard 700mm (27.5") doorway. All Beech Ovens can be installed without the use of a crane therefore significantly reducing the costs of installation. The oven body comes with an exclusive 4 year guarantee.

The oven can be installed within 75mm (3") (*including 50mm (2") of insulating wool and 25mm (1") air gap*) of non-combustible material (*check local building and fire codes*). The oven exhausts through a spigot above the oven mouth. The oven must be vented in accordance with local and/or national codes. Refer to "Duct Design Options" or for more information, refer to the Installation and Operation Manual located on our website www.beechovens.com
Allow 600mm sq (24" x 24") ventilation into the underside of the oven for secondary air to the gas burner (*if applicable*).

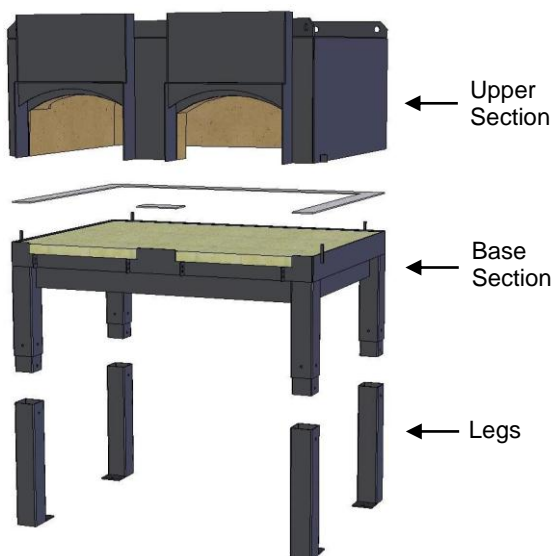

Unique Features

Wood or thermostatically controlled gas system.
Easy installation into most areas (*three (3) piece assembly*).
Stainless steel plug door for oven mouth.
Any gas type – Specify at order time.

Optional Accessories

- Internal spotlight.
- Gas fired Char Grill with slide out drawer.
- Viewing window available in any location.
- Various shape/design facades and Stainless Steel Hearths.
- Thermostatically controlled Display burner.
- Exhaust Fan/Hood.
- Stainless Steel pizza tools.
- Service panels/hearth/lintel extensions.

Approximate Pizza Capacity Per Hour

At 250°C (482°F) floor temperature the oven will cook:

Size	200mm (8")	250mm (10")	300mm (12")	400mm (16")
Pizza / hour	190	115	70	48

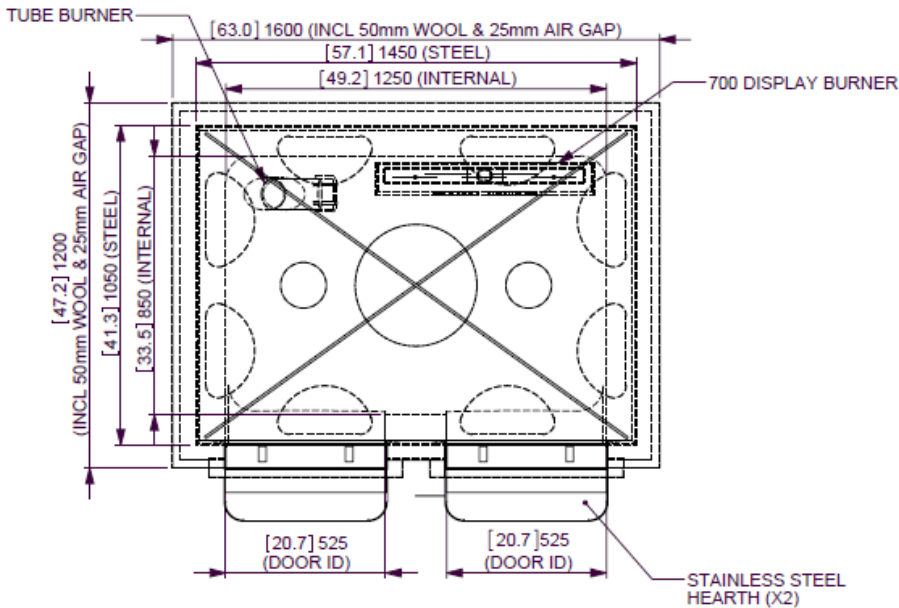

NOTES:
CONNECTION TO APPROVED FLUE/DUCTING REQUIRED
(CHECK LOCAL CODES AND REGULATIONS)

THE OVEN IS DELIVERED IN THREE (3) SECTIONS:
UPPER SECTION - Approx 850kg
BASE SECTION - Approx 450kg
LEGS - Approx 10kg EACH

TOTAL WEIGHT = Approx 1600kg

SERVICES REQUIRED - SEE BLUE TEXT

FOR INSTALLATION INSTRUCTIONS SEE INSTALLATION AND OPERATION MANUAL

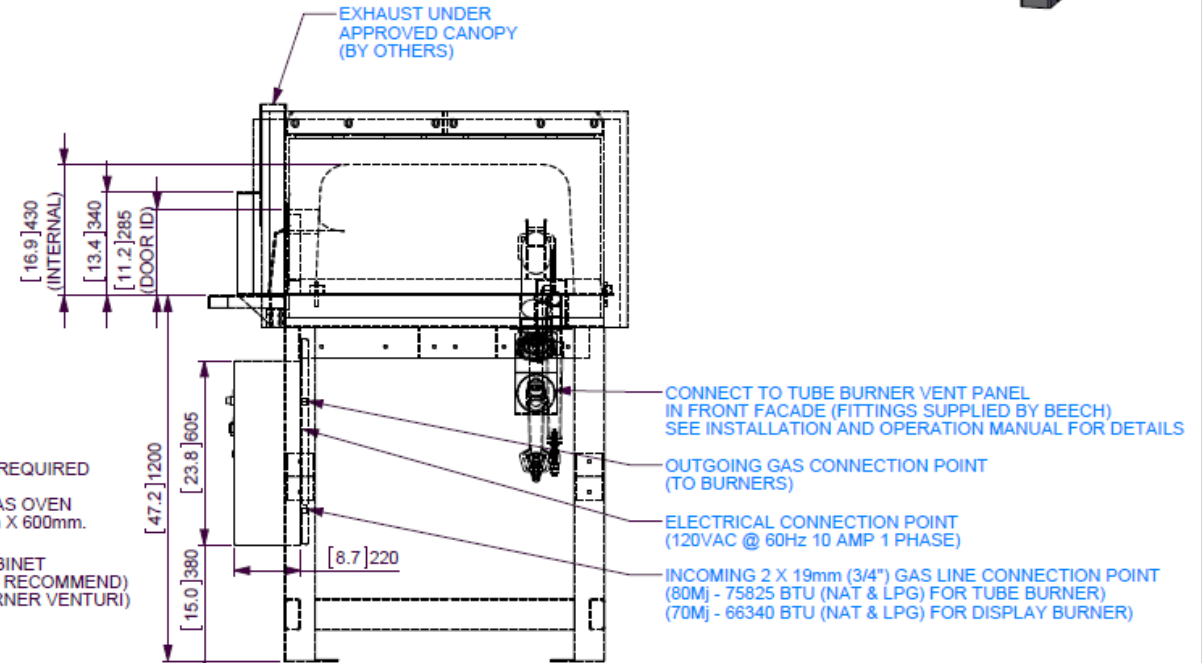
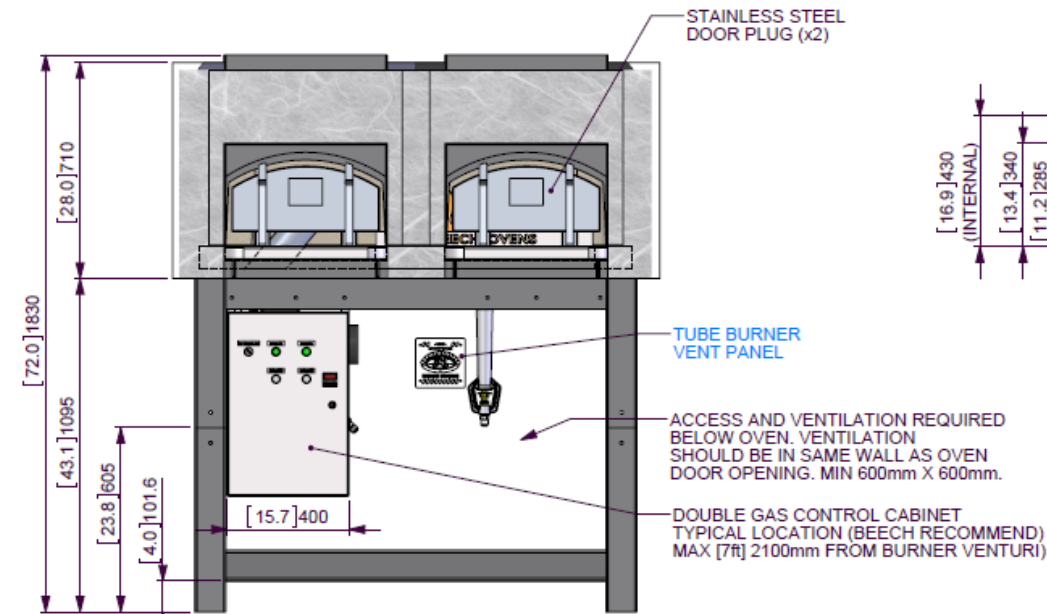
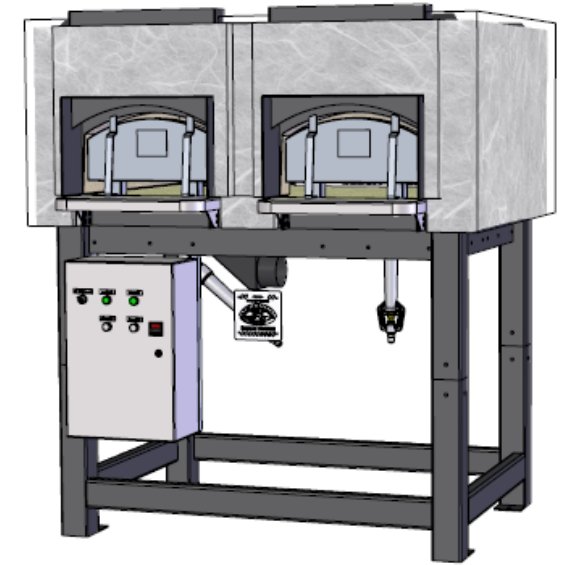

REV.	DESCRIPTION OF CHANGES	DATE	CHANGED BY
0	ISSUED FOR CONSTRUCTION		

LAST EDITED: Wednesday, 22 July 2015 11:11:50 AM

©Copyright 2015 Beech Ovens Pty Ltd. All rights reserved.



www.beechovens.com

Drawn	M. WEBB	Checked		Scale	1:17	Date	22/07/2015	
RECTANGULAR OVEN 1250mm ID FGR (DISPLAY RIGHT - TUBE LEFT) SS HEARTH								A3
							NTS - SITE MEASURE	

REC1250-2020 - DETAILS-USA