



Project Name: _____

Location: _____

Item #: _____

Qty: _____

Grista Sandwich/Salad Prep Table, 2 Door - 15 Cu Ft, 60"

GRSL-2D/60



Easily prepare fresh, made-to-order sandwiches and salads with the Grista 2 Door Refrigerated Salad and Sandwich Prep Table. This commercial prep table keeps ingredients at safe temperatures, enhances kitchen efficiency and provides a convenient workspace for staff. Ideal for any sandwich shop, deli, pizzeria, restaurant or cafe, this durable stainless-steel two-door cold prep station is designed with easy-to-grip recessed door handles and two plastic-coated shelves to store ingredients.

FEATURES AND CONSTRUCTION

- Durable 430 series stainless steel exterior and painted aluminum interior
- Two doors with recessed handles
- One plastic-coated wire shelf per section/door
- Equipped with a 3/4" thick removable polyethylene cutting board that provides a convenient space for assembling sandwiches and salads
- Cold topping area holds a variety of different sized food pans up to 6" deep
- Hinged insulated cover keeps food items cold when not in service
- 15 cu ft (425 L) storage capacity
- Precise digital temperature controller with LED display
- Temperature range of 33°F to 41°F (1°C to 5°C)
- (4) 4" casters (2 locking and 2 non-locking) for easy mobility in your commercial kitchen

ELECTRIC

115V / 60Hz / 1Ph
Cord Length (Inches): 98.40"
Plug Type: NEMA-5-15P
Cord set included

NEMA 5-15P



3RD PARTY APPROVALS



Intertek



Intertek

WARRANTY (USA / CANADA)

2 Year Warranty on Parts & Labor, 5 Years on Compressor
Contact Admiral Craft Equipment for details at 1-877-672-7740



NOMINAL STORAGE CAPACITY

Cubic Feet: 18.4 cu. ft.

TEMPERATURE

Holding Temperature (Fahrenheit): 33° - 40°

These models are designed to operate in an environment where temperature and humidity do not exceed 75°F (24°C) and 55% relative humidity



Grista Sandwich/Salad Prep Table, 2 Door - 15 Cu Ft, 60"

GRSL-2D/60

FRONT

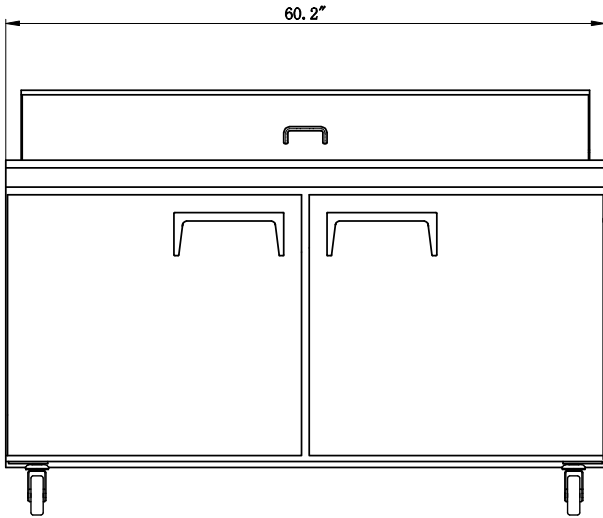

SIDE

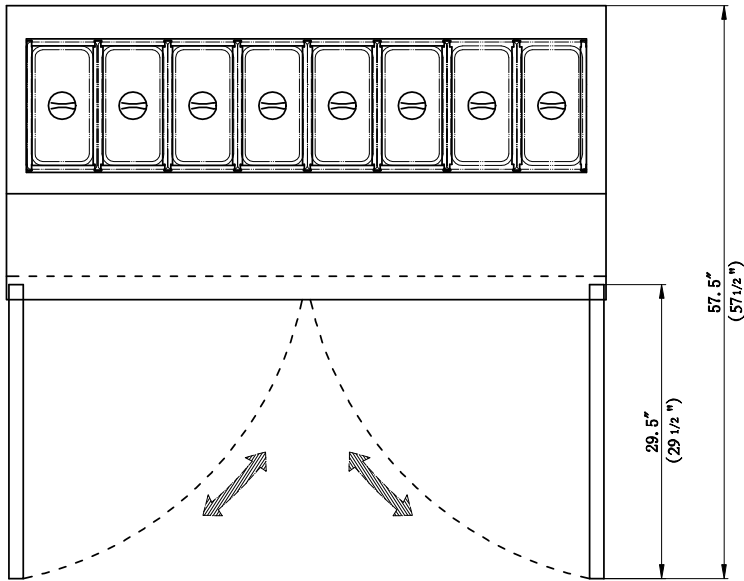
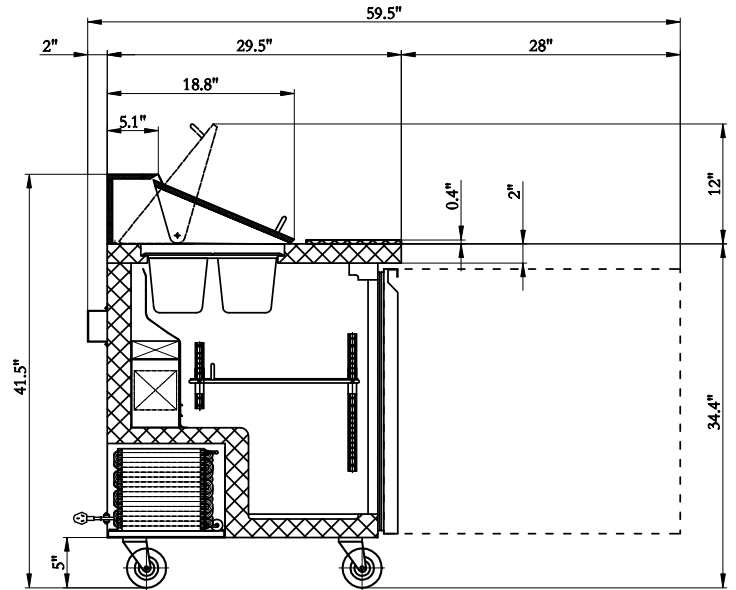

TOP

Sandwich and Salad Prep Tables

Doors	Shelves	Amps	HP	Refrigerant	Capacity	Dimensions	Item Weight lbs	Shipping Weight lbs
2	2	5.4A	0.75	R290	18.4 cu. ft.	60.2" x 29.5" x 42.3"	319.0	416.0

Due to periodic changes in designs, methods, procedures, policies and regulations, the specifications contained in this document are subject to change without notice. While we exercise good faith efforts to provide information that is accurate, we are not responsible for errors or omissions in information provided or conclusions reached as a result of using the specifications. By using the information provided, the user assumes all risks in connection with such use.