



# BEVERAGE-AIR

Project: _____	AIA#
Item: _____	SIS#
Location: _____	
Approved: _____	

# WTFD32AHC WORKTOP FREEZER

**WORKTOP FREEZER**  
**WTFD32AHC Flat Top With Drawers**  
**Hydrocarbon Series**

**MODEL:**  
**WTFD32AHC-2-FLT**



**7 Year Parts/Labor Warranty**  
**7 Year Compressor Warranty**

### CABINET CONSTRUCTION

- Stainless steel front, sides, drawers and grille (galvanized back & bottom)
- Interior liner is made of corrosion resistant aluminum
- Stainless steel worktop for added durability
- Flat top
- Full electronic control
- Interior thermometer is standard
- Snap-in drawer gaskets
- Upper and lower pull-out drawers accommodate 6" deep pans
- Stainless steel drawer frames supported on telescoping drawer slides
- Drawer slides include locking mechanism that prevents drawer from being inadvertently pulled off cabinet
- 6" Casters, (2) with brakes standard

### OPTIONS & ACCESSORIES

- Stainless steel back
- Stainless steel interior
- Cutting board
- 6" Legs (stainless steel, black or seismic/flange)
- Low profile casters
- Remote option\* (see note on back on page)

### REFRIGERATION SYSTEM

- Uses environmentally friendly, energy efficient R290 refrigerant, and meets all regulatory requirements for CARB, SNAP, DOE & more
- Adaptive defrost
- Epoxy coated evaporator coil
- Freezers capable of maintaining product temperature of -10°F



  
 Please verify qualifying units by visiting:  
[www.energystar.gov/cfs](http://www.energystar.gov/cfs)

3779 Champion Blvd., Winston-Salem, NC 27105  
 1-888-845-9800 Fax: 1-336-245-6453  
 Beverage-Air.com Sales@bevair.com



# BEVERAGE-AIR

MODEL	WTFD32AHC-2-FLT
<b>EXTERNAL DIMENSIONAL DATA</b>	
Width Overall	32"
Depth Overall with Handle & Bumper	32"
Height Overall with 6" Casters	35 1/2"
Number of Drawers	2
Depth with Drawer Extended	48 1/2"
Drawer Openings	(2) 27 5/8" x 9 3/8"
<b>INTERNAL DIMENSIONAL DATA</b>	
NET Capacity (cubic ft.)	7.2
Internal Width Overall (in)	28"
Internal Depth Overall (in)	15 3/8"
Internal Height Overall (in)	23"
<b>ELECTRICAL DATA</b>	
Full Load Amperes	4.0
Voltage	115/60/1
Nema Plug (8' cord)	5-15P
<b>REFRIGERATION DATA</b>	
Horsepower	1/3+
Capacity (BTU/Hr)	1184
Heat Rejection (BTU/Hr)	1776
Charge (lbs/grams/ounces)	0.165 / 75 / 2.64
<b>SHIPPING DATA</b>	
Gross Weight - Crated	240 lbs
Height - Crated	35"
Width - Crated	35"
Depth - Crated	33"

\*NOTE: Remote units are field wired and come with 6" legs. Refrigerant must be specified at time of order.

We reserve the right to change specifications and product design without notice. Such revisions do not entitle the buyer to corresponding changes, improvements, additions or replacements for previously purchased equipment. Dimensional tolerances +/- 1/4". Metric dimensions (MM).

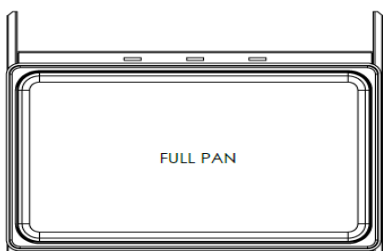

## Worktop Freezer With Drawers Model: WTFD32AHC-2-FLT

### Model Views

Required Clearance: 3" Bottom & 2" Rear

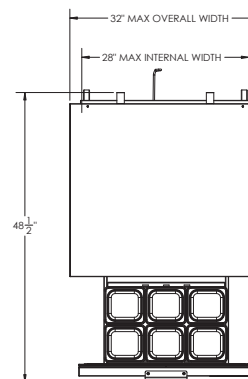

### PLAN VIEW

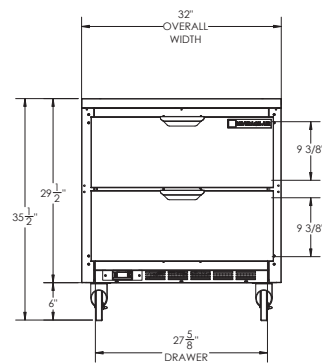

### ELEVATION VIEW

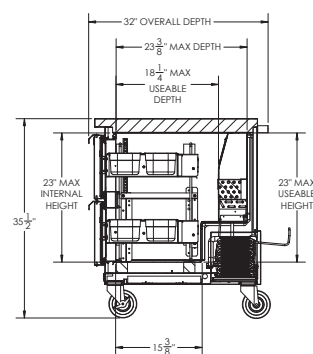

### SIDE VIEW

### ELECTRICAL CONNECTION



115/60/1  
NEMA 5-15P

Unit pre-wired at factory and include 8' long cord and plug set.

