







BLUELAX

CHARBROILER BLCB24

PRODUCT DESCRIPTION

-  35,000 BTU per Burner every 12"
-  Cool-Touch Front Stainless Steel Landing ledge
-  Easy access Full size crumb tray
-  Shipped Standard as Natural Gas, LP conversion Kit included.
-  Easy to remove full width crumb tray.
-  High Quality and durable Stainless Steel design



Charbroiler Knobs



Cast Iron Waste and Oil Drain

Radiant Burner

Radiant Burner Cover

MODEL#

DIMENSIONS

BLCB24

Width Depth Height

24 in 28 3/4 in 15 3/8 in

* All measures are presented in Inches



223 W. Rosecrans Ave. Gardena, CA 90248
T : 310.808.0102
F:310.808.0242

9 W. Shelton Terrace #A Hillside, NJ 07025
T : 908.688.0970
F : 908.688.8143

DETAILS & SPECIFICATIONS

CHARBROILER BLCB24

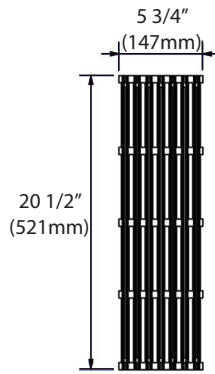
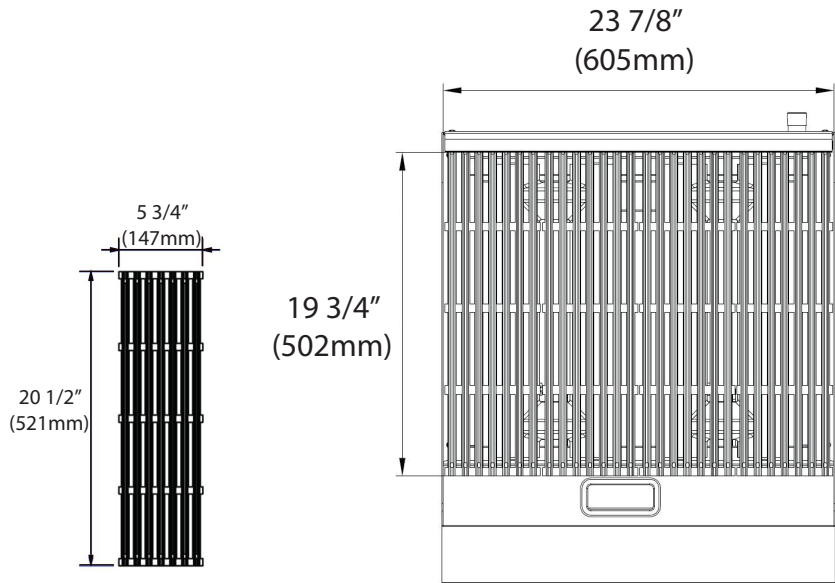
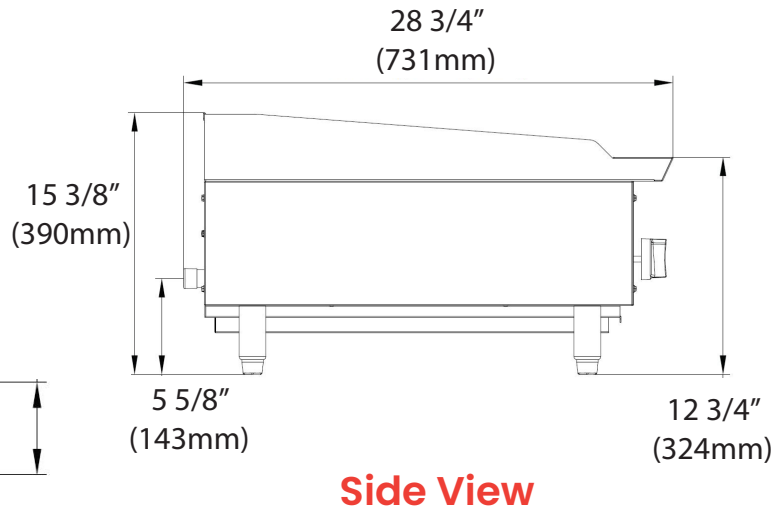
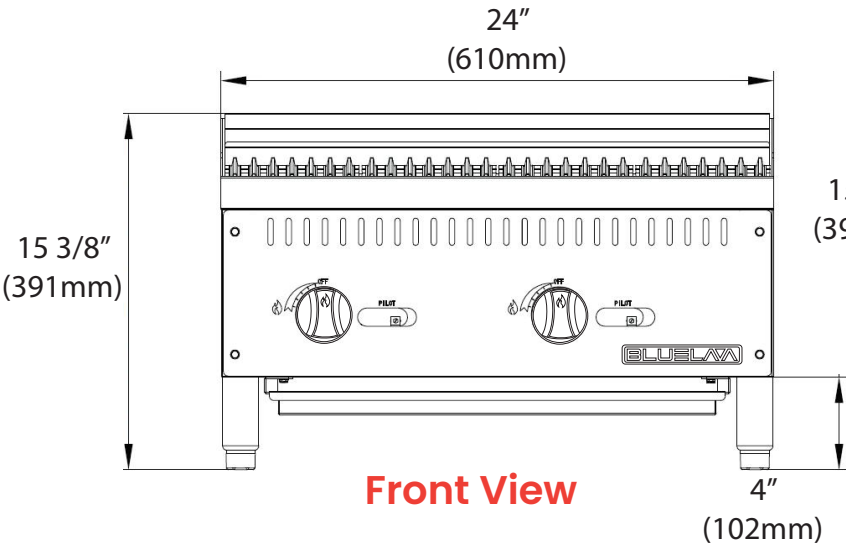

BLCB24

GAS	NG/Propane
EQUIPMENT DIMENSIONS	23.86x20.47in
BURNERS	2
BTU/H PER BURNER	35,000
TOTAL BTU/H	70,000
GAS PRESSURE	NG: 4 "WC Propane: 10 "WC
NOZZLE	NG: #34 Propane: 49#
CONTAINER FITMENT	250

Model	Packaging Dimensions (inches)			Net Weight (lbs)	Ship Weight (lbs)
	W	D	H		
BLCB24	26 1/8"	32 5/8"	20 1/2"	132	154



orders@blueairfse.com

223 W. Rosecrans Ave. Gardena, CA 90248
T: 310.808.0102
F: 310.808.0242

9 W. Shelton Terrace #A Hillside, NJ 07025
T: 908.688.0970
F: 908.688.8143