

## Product Specifications Front-Venting Freezers

- Create a seamless, built-in look that adds a clean, professional appearance, ideal for open kitchens or customer-facing areas.
- Ensure efficient operation in high-traffic areas by directing heat away from the interior, maintaining consistent airflow even in compact spaces.
- Unidirectional casters included for easy maneuverability and stability in tight spaces.



UCFZ336-SS61A



UCFZ348-SS61A



UCFZ360-SS61A



UCFZ372-SS61A

Model	Description	Voltage/Hz/Phase/Amps	Shipping Weight
UCFZ336-SS61A	2 Door Front-Venting Freezer	115 / 60 / 1 / 6	264 lb
UCFZ348-SS61A	2 Door Front-Venting Freezer	115 / 60 / 1 / 6	319 lb
UCFZ360-SS61A	2 Door Front-Venting Freezer	115 / 60 / 1 / 6	342 lb
UCFZ372-SS61A	3 Door Front-Venting Freezer	115 / 60 / 1 / 12	452 lb

### Specifications

UCFZ336-SS61A dimensions: 33 <sup>31</sup>/<sub>32</sub>" H x 36 <sup>5</sup>/<sub>22</sub>" W x 31 <sup>13</sup>/<sub>16</sub>" D

UCFZ348-SS61A dimensions: 33 <sup>31</sup>/<sub>32</sub>" H X 48" W X 31 <sup>3</sup>/<sub>4</sub>" D

UCFZ360-SS61A dimensions: 33 <sup>31</sup>/<sub>32</sub>" H X 60 <sup>13</sup>/<sub>32</sub>" W X 31 <sup>3</sup>/<sub>4</sub>" D

UCFZ372-SS61A dimensions: 33 <sup>31</sup>/<sub>32</sub>" H X 71 <sup>29</sup>/<sub>32</sub>" W X 31 <sup>3</sup>/<sub>4</sub>" D

UCFZ336-SS61A: volume of 9.29 cu ft, 2 epoxy coated shelves

UCFZ348-SS61A: volume of 13.17 cu ft, 2 epoxy coated shelves

UCFZ360-SS61A: volume of 17.04 cu ft, 2 epoxy coated shelves

UCFZ372-SS61A: volume of 19.86 cu ft, 3 epoxy coated shelves

AISI 304 stainless steel interior and exterior

Autodefrost

CFC-free high density polyurethane insulated cabinet

Electronic Control

Environmentally friendly R290 refrigerant

Epoxy coated, sealed evaporator eliminates potential corrosion

Factory pre-wired for dedicated outlet, 11 ft cord and plug included NEMA 5-15P

NSF/ANSI Standard 7 compliant

Temperature range: -13°F to 14°F



# Product Specifications • Front-Venting Freezers

### Top (UCFZ336)

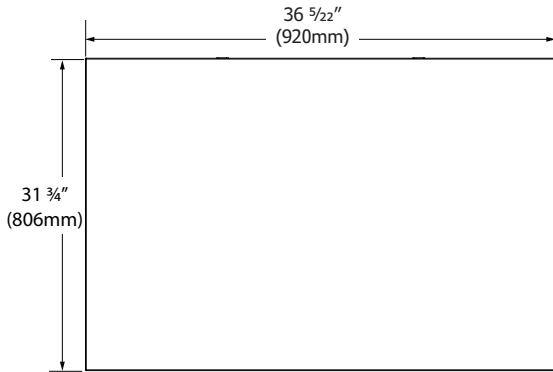

### Top (UCFZ348)

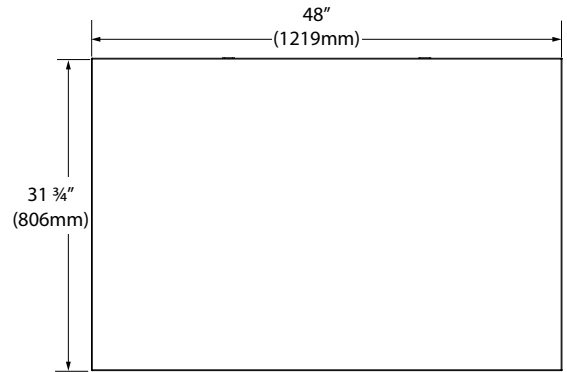

### Top (UCFZ372)

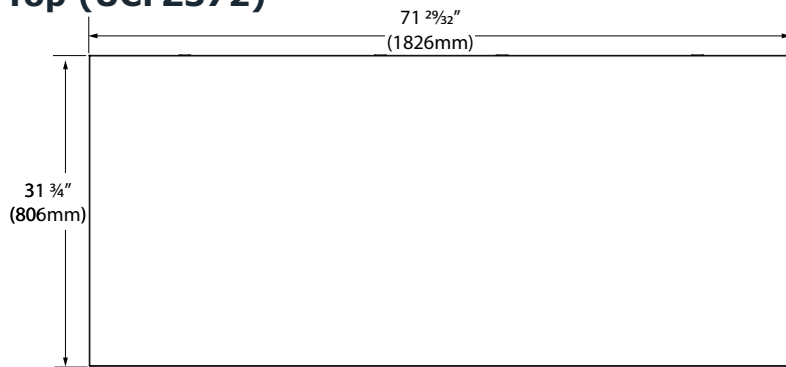

### Top (UCFZ360)

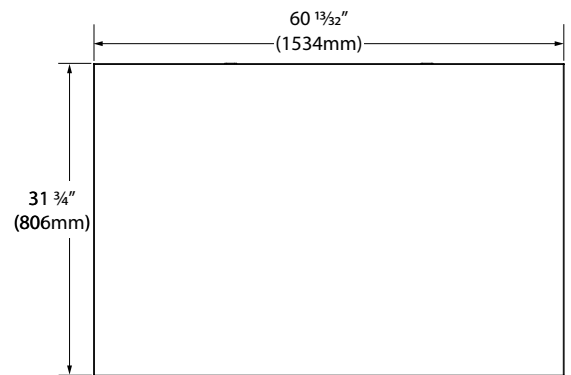

### Front (UCFZ336, 348, 360)

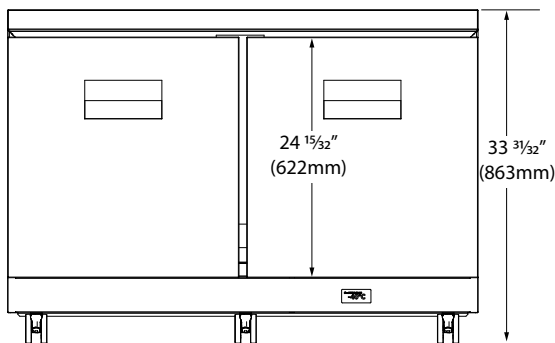

### Side (all models)

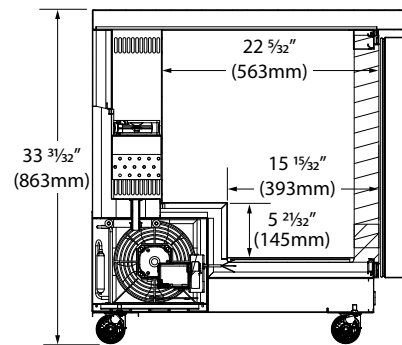

### Front (UCFZ372)

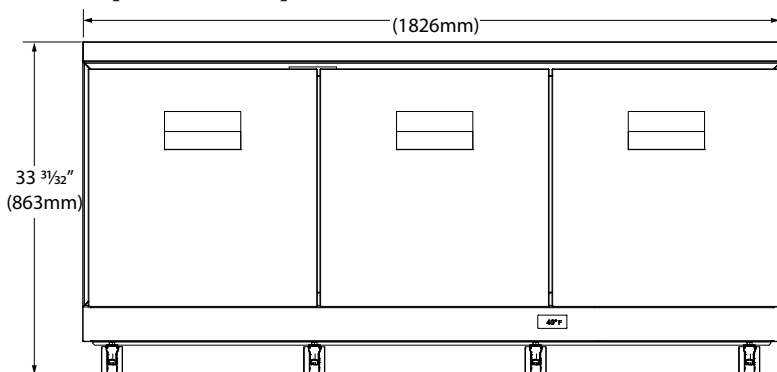

Intertek

## Commercial Warranty

3 Year (parts & labor) / 5 year sealed system (parts)  
See complete warranty for details