

Operations & Service Manual

GBF Series Fryers



Model: GBF-35/50
Single



Model: GBF-35/50 Banked



Giles Enterprises, Inc.

2750 Gunter Park Drive West • Montgomery, AL 36109 USA

Phone Toll Free: 800.554.4537 (USA & Canada Only)

Phone: 334.272.1457

Fax: 334.239.4117 • Website: www.gfse.com

Form No. 65686 (Release date: 04/20/11) Rev. C



Record the following information here for easy, quick reference

Model: _____

Serial Number(s) - record left fryer to right fryer for "banked" systems; each unit has its own serial number:

Voltage: _____ **Phase:** _____

Date Installed: _____

Be ready to provide this information when calling for service or repair parts.



LIMITED WARRANTY

- Subject to the terms and conditions of this Limited Warranty as herein stated, all Giles Enterprises, Inc., Foodservice Equipment and parts purchased new from an authorized Giles Enterprises, Inc., representative are warranted as to defects in material or workmanship for a period of 12 months from the date of installation, provided, however, that with regard to labor costs in connection with this warranty, see below. All installations must be made by a qualified installing agency in accordance with all applicable codes and/or regulations in the jurisdiction in which installed. Limited warranty coverage is extended to the original owner only and is void if the unit is resold.
- During the Limited Warranty period, Giles Enterprises, Inc. will replace or recondition, at its factory, any part or parts of this unit which Giles Enterprises, Inc. inspectors judge defective, provided the unit has been subjected to normal usage, properly installed, operated and serviced. This Limited Warranty does not cover cosmetic damage, and damage due to acts of God, accident, misuse, alteration, negligence, abuse of the Giles Foodservice Equipment or the use of unorthodox repair methods. All parts replaced under this Limited Warranty carry only the unexpired term of this Limited Warranty. Limited Warranty service may be furnished only by an authorized Giles Enterprises, Inc., representative.
- If Limited Warranty service is requested, Giles Enterprises, Inc., will send factory-authorized service representatives to repair, recondition, replace or inspect units of its manufacture with such labor being rendered without cost to owner for ninety (90) days from the date of installation. Otherwise, service, including labor and transportation charges or other expenses, in connection with the removal or installation of any part or parts supplied under this Limited Warranty, are specified on the original sales contract between the purchaser and the authorized Giles Enterprises, Inc., representative.
- Giles Enterprises, Inc. reserves the right to change or improve its equipment and parts in any way without obligation to alter such equipment or parts previously manufactured.
- Giles Enterprises, Inc. makes no further warranties, express or implied including implied warranties of merchantability or fitness for a particular purpose, and has no other obligation or liability not specifically stated herein.
- Repair or replacement as provided under this limited warranty is the exclusive remedy. Giles Enterprises, Inc., shall not be liable for any incidental or consequential damages for breach of any express or implied warranty on this product, except to the extent prohibited by applicable law. Any implied warranty of merchantability or fitness for a particular purpose on this product is limited in duration to the duration of this limited warranty.
- Used Giles Enterprises, Inc., Foodservice Equipment or parts or Giles Enterprises, Inc., Foodservice Equipment or parts not purchased from an authorized Giles Enterprises, Inc., representative, carry no warranties, express or implied.



Safety	vi
Safety Overview	vi
Specific Safety Precautions	vii
1. Introduction	1
1.01 Construction	1
1.02 Standard Features	1
1.03 Optional Features	1
1.04 Specifications	2
1.04.1 Overall Dimensions for Single & "Banked" Fryer systems	2
1.04.2 Regulatory Listings	3
1.04.3 Basket Size	3
1.04.4 Vat Size and Capacity	3
1.04.5 Shipping Specifications (Crated)	4
2. Installation	5
2.01 Location	5
2.02 Unpacking	6
2.03 Electrical Requirements	7
2.04 Electrical Specifications (per Fryer Unit)	7
2.05 Electrical Connections	8
2.05.1 Electrical Connection Diagram	8
2.06 Ventilation of Fryer	9
2.07 Restraint Device	9
3. Overview	11
3.01 Auto-Basket Lifts & Baskets	12
3.02 Control Panel	14
3.02.1 Control Panel - Computer Controller	14
3.02.2 Control Panel - Mechanical Controls	16
3.03 Lower Cabinet Area - Single Fryer & Base Unit of "banked" systems	18
3.04 Lower Cabinet Area - Add-on Fryer for "banked" systems	20
3.05 Filter Pan Unit - Single Fryer & Base Unit of "banked" systems	22
3.06 Filter Pan Assembly	24
3.07 Accessories (Included)	26
3.08 Accessories (Not Included)	28
4. Unit Preparation	31
4.01 Set-up Fryer(s) for Check-out	32
4.02 Power test	33
4.03 Heating Element Test	34
4.03.1 Heating Element Test - Computer Controller	34
4.03.2 Heating Element Test - Mechanical Controls	35
4.04 Filter Pump Test	37
4.05 Boil-Out Procedure	38

4.06	Clean Filter Pan.....	38
5.	Fryer Operation.....	39
5.01	Cooking Controller.....	40
5.01.1	<u>Computer Controller - Overview</u>	40
5.01.1.1	Keys and Functions.....	41
5.01.1.2	Programming Cooking Temperature.....	42
5.01.1.3	Programming Cooking Time.....	43
5.01.1.4	Start a Cooking Time.....	44
5.01.1.5	Cancel a Running Cooking Time.....	44
5.01.1.6	Manually Lowering and Raising the Cook Baskets (Basket Lift Option Only).....	44
5.01.1.7	Display Cook Time Remaining.....	45
5.01.1.8	Displaying Actual Temperature of the Shortening.....	45
5.01.2	<u>Mechanical Controls - Overview</u>	46
5.01.2.1	Setting the Temperature Unit of Measure.....	47
5.01.2.2	Setting a Cooking Temperature.....	48
5.01.2.3	Setting a Cooking Time.....	49
5.02	<u>Cooking Procedure</u>	50
5.02.1	Cooking Procedure - Computer Controller.....	52
5.02.2	Cooking Procedure - Mechanical Controls.....	55
5.03	Filtering Liquid Shortening.....	58
5-04	Removal of Used Liquid Shortening.....	61
5.05	Normal Shut-Down.....	64
5.06	Emergency Shut-Down.....	64
6.	Cleaning.....	65
6.01	Boil-Out Procedure (Cleaning the Fry Vat).....	65
6.02	Cleaning the Filter Pan & Refreshing Filter Media.....	68
7.	Troubleshooting.....	70
7.01	Temperature Control System.....	70
7.02	Oil Filtration System.....	72
7.03	Basket Elevator System (Basket Elevator Option Only).....	73
8.	Parts Listing.....	75
8.01	Parts Ordering & Service Information.....	75
8.02	Control Panels (Computer & Mechanical) - Single or Main Unit of Battery.....	76
8.03	Control Panels (Computer & Mechanical) - Add-on Unit of Battery.....	78
8.04	Lower Cabinet - Single or Main Unit of Battery.....	80
8.05	Lower Cabinet - Add-on Unit of Battery.....	82
8.06	Control Box Front.....	84
8.07	Rear Cabinet - Single Unit.....	86
8.08	Rear Cabinet - Banked Fryer Battery.....	88
8.09	Cabinet Underside - Banked Fryer Battery.....	90



8.10	Fry Vat Assembly	92
8.11	Filter Pan Assembly	94

Notes:

Safety

Safety Overview

The instructions contained in this manual are intended to aid in learning the proper procedures for installing, operating and servicing this unit.

Throughout this manual, safety precautions are identified by use of safety alert symbols and three alert keywords: **DANGER ... WARNING ... CAUTION**. Safety alert information precedes the step(s) or activity to which it applies. Suggested, recommended, or other noteworthy information is identified by use of the keyword **NOTE**. Additionally, certain key words are used to indicate a specific meaning or add emphasis as follows:

Shall: understood to mean mandatory.

Should: understood to mean advisory.

May: understood to mean permissive or possible.

Will: indicates the occurrence of a future predictable event or condition.



Safety Alert Symbols

Used in conjunction with key alert words (**DANGER ... WARNING ... CAUTION**) to signify potential personal injury hazards. These alerts immediately precede precautionary information. Adhere to all safety notices following these symbols to avoid possible injury or death. Failure to comply with safety precautions identified by the safety alert symbols may also void the manufacturer's warranty.

DANGER

- Indicates an imminently hazardous situation, which will result in serious personal injury and possible death, if not avoided. Use of this alert is limited to the most extreme situations.

WARNING

- Indicates a potentially hazardous situation, which could result in serious personal injury and possible death, if not avoided.

CAUTION

- Indicates a potentially hazardous situation or unsafe practice, which may result in minor to moderate personal injury, if not avoided.

CAUTION

- When used without the safety alert symbol, **CAUTION** indicates a potentially hazardous situation which, may result in equipment or property damage and void the warranty, if not avoided.

NOTE:

- Identifies suggested, recommended or other noteworthy information.

Specific Safety Precautions

For your safety, please read and observe the following precautions when operating or servicing this unit. Adherence to this important safety information will help prevent personal injury and/or equipment damage.

DANGER

- Turn off the Fryer and disconnect supply power to it before cleaning or performing any maintenance activity.
- **DO NOT** wash down the unit's interior or exterior with water from a spray hose.
- Failure to comply with these **DANGER** notices can result in death or serious injury, equipment or property damage and void the warranty.

WARNING

- Consult a qualified electrician to ensure that:
 - > all electrical specification and code requirements are met, and
 - > circuit breakers and wiring are of sufficient rating and gauge for this equipment.
- During installation, the unit must be properly grounded and must comply with all electrical requirements.
- Improper installation or adjustment, unauthorized alteration, or improper service and maintenance could result in death or serious personal injury, equipment or property damage, and void the warranty.
- **DO NOT** use or store gasoline, other flammable liquids, or materials that release flammable vapors in the vicinity of this or any other electrical appliance!
- During cooking operations, the oil level **MUST** be maintained above the indicated minimum level. If not maintained above that level the heating elements will shutdown.
- Failure to comply with **WARNING** notices could result in death or serious personal injury, equipment or property damage, and void the warranty.

CAUTION

- The unit must remain in an upright (vertical) position.
- Exercise care when unwrapping and removing the unit from the shipping skid.
- **DO NOT** operate this unit unless its components and their intended functions are fully understood. Before attempting to operate the unit, refer to **Section 3** and become familiar with the various controls.
- Certain parts of this unit become extremely **HOT** during normal operation. To avoid personal injury, exercise due caution when operating, loading and unloading food product, cleaning, or servicing the equipment. As appropriate, it is recommended that thermal oven mitts be worn when attending this unit.
- Allow the unit to cool down a minimum of 15 to 20 minutes before cleaning or servicing.
- Introducing overly wet food items or larger than recommended load sizes into the cook vat can lead to a surge boil, resulting in an overflow of **HOT** cooking oil from the vat. Exercise due caution when loading food for cooking and observe how the hot oil reacts before continuing.
- Cooked food products must be maintained at a minimum temperature of 150°F (65.5°C) or in accordance with local and state health regulations, while being held prior to serving or sale.
- **Fryers must be properly grounded. Improper grounding may result in electrical shock. Always refer to local electrical code for proper grounding technique of this or any other electrical equipment. Always consult a certified electrician or other qualified service person to ensure that circuit breakers and wiring are of sufficient rating and gauge for this equipment, and that the equipment is properly grounded.**
- Giles electric Fryers are manufactured to operate with a specific voltage, phase and frequency. Check the rating label, or plate, on the rear panel or inside the front door of the Fryer cabinet to determine correct required supply power.
- Ensure that the Fryer is positioned in a secure, safe location with casters locked and an appropriate restraining device installed.
- The wiring diagram provided with this equipment should aid electricians/technicians with installation of Fryer.
- Be careful not to puncture the Filter Pan's filter media if using a Drain Brush, or other implement, to clean the Fryer's drain valve and tube in the event of a clog.
- Failure to comply with **CAUTION** notices may result in minor to moderate personal injury, equipment or property damage, and void the warranty.

CAUTION

- This appliance is not intended for use by persons (including children) with reduced physical, sensory, or mental capabilities, or lack of experience and knowledge, unless they have been given adequate instruction and/or supervision concerning its use by a person responsible for their safety. Children should be supervised, or otherwise restricted, to ensure they do not play with or around this appliance.
- The electronic components on the Control Panel face and inside the control box, are impact-sensitive. To prevent damage, exercise care when operating the Fryer and when maneuvering carts or other rolling fixtures in the vicinity of the Fryer.
- **DO NOT** install the unit immediately adjacent to combustible walls or materials. Failure to maintain safe distances from combustibles may present a risk of fire.
- When cleaning the Fryer:
 - > **DO NOT** steam clean unit.
 - > **DO NOT** use products containing chlorine.
 - > **DO NOT** use abrasive products, steel wool or scouring pads.
 - > **DO NOT** use oven cleaners.
- Failure to comply with these **CAUTION** notices may result in equipment or property damage and void the warranty.
- Failure to comply with these **CAUTION** notices may violate local health codes.
- **DO NOT** modify, alter or install unauthorized attachments on this equipment!

NOTE:

- It is the responsibility of the customer to inspect the equipment upon receipt and report any shipping damages to the freight company. If the palletized unit shows evidence of damage, immediately inspect the unit and accompanying accessories. Note any damages on the freight bill and notify the carrier. It is at the discretion of the customer whether or not to refuse delivery of freight damaged equipment.
- To aid installation technicians and electricians, a wiring diagram is provided with this manual. Refer to it during installation or service.
- Comply with all appropriate state and/or local health regulations regarding cleaning and sanitation of this equipment.



1. Introduction

Congratulations on the purchase of a new Giles GBF-Series Fryer, manufactured by Giles Enterprises, Inc., Montgomery, Alabama (USA). All of the equipment we manufacture is thoroughly inspected and tested prior to shipment and with proper care and maintenance, it will provide years of trouble-free service.

To help protect your investment in this state-of-the-art cooking equipment, we recommend that you take a few moments to familiarize yourself with the installation, operational, and maintenance procedures contained in this manual. Adherence to these recommended procedures will minimize potential for unnecessary repair expense and costly “down-time”.

Please retain this manual and keep it handy for future reference.

1.01 Construction

The GBF Model Fryer’s exterior and fry vat are constructed of 18 and 20 gauge stainless steel. The inner cabinet structure is of welded tubular stainless steel.

1.02 Standard Features

Computer Controller: Electronic, micro-processor, cooking controller regulates cook cycle and monitors fryer’s status ... Two (2) basket timers, each with four (4) programmable menu keys ... Features included: cool-mode, force filter function & low oil level safety shutdown.

Filtration System: On-board oil filtration system ... designed to service multi-fryer banked configurations.

Bankable: Can be ordered as a banked battery of 2, 3, 4, or 5 fryer units.

Reusable, Stainless Micro-Mesh Filter Screen: Environmentally friendly solution for “Sustainability” and “Green” initiatives ... reduces long term cost of operation.

1.03 Optional Features

Automatic Basket Lift: Two (2) Basket Lifts per vat ... automatically lifts cooked product from hot oil at the end of set cook cycle.

Mechanical Cooking Controls: Two (2) mechanical 30-minute basket timers and a digital thermostat ... replaces computer controller.

1.04 Specifications

1.04.1 Overall Dimensions - Single & Banked Systems

SINGLE FRYER UNIT:

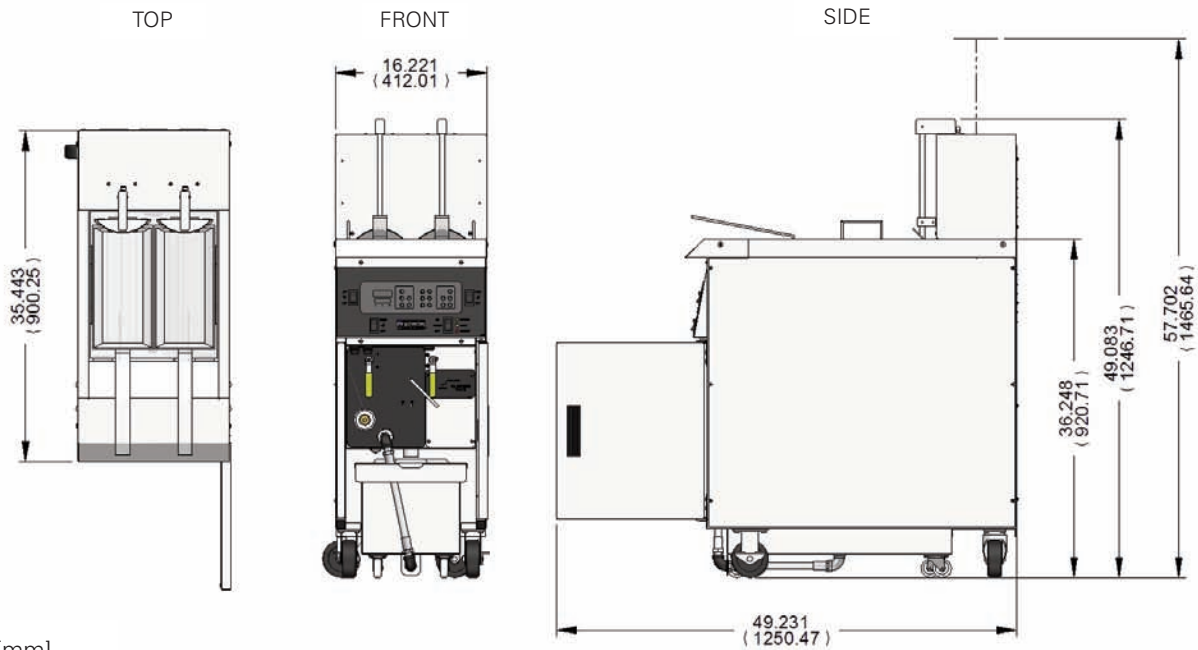

INCHES [mm]

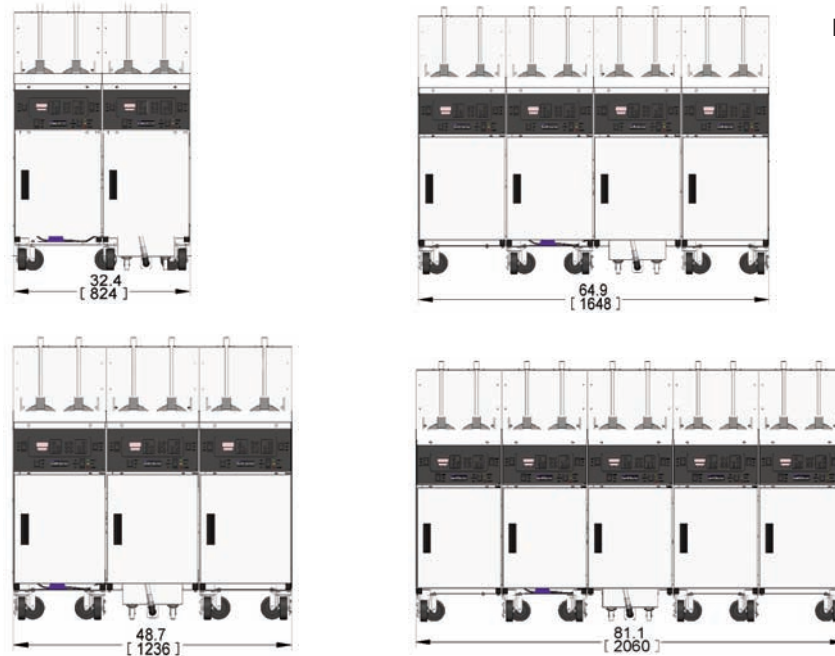

BANKED FRYER UNITS:

1.04.2 Regulatory Listings



UL LISTED



CLASSIFIED
UL
EPH



CE

Only 380-415V models with computer controls are CE listed.

1.04.3 Basket Size

Description	Length	Width	Height	Volume
Standard (2 per vat)	13.25 [336.6]	6.50 [165.1]	6.00 [152.4]	423.6 cu.in [6,942.8 cc]

INCHES [mm]

1.04.4 Vat Size & Capacity

Model	Length (Inside)	Width (Inside)	Height (Top of element to "Full" Level)	Liquid Shortening Capacity (Bottom of vat to "Full" Level)	
				Lbs [kg]	Gal [l]
GBF-50	16.25 [412.8]	13.90 [353.1]	4.97 [126.2]	50 [22.7]	7.1 [26.9]
GBF-35	16.25 [412.8]	13.90 [353.1]	3.50 [88.9]	35 [15.9]	5.0 [18.9]

INCHES [mm]

1.04.5 Shipping Specifications (Crated)

Model	Gr. Wt.	Crated Size			Cube
		Length	Width	Height	
GBF35/50-1	326 lbs (147.9 kg)	48" (1.22 m)	40" (1.02 m)	55.7" (1.41 m)	61.9 cu.ft (1.75 cu.m)
GBF35/50-2	593 lbs (269.0 kg)	48" (1.22 m)	40" (1.02 m)	55.7" (1.41 m)	61.9 cu.ft (1.75 cu.m)
GBF35/50-3	895 lbs (406.0 kg)	96" (2.44 m)	40" (1.02 m)	55.7" (1.41 m)	123.8 cu.ft (3.51 cu.m)
GBF35/50-4	1162 lbs (527.1 kg)	96" (2.44 m)	40" (1.02 m)	55.7" (1.41 m)	123.8 cu.ft (3.51 cu.m)
GBF35/50-5	1415 lbs (642.8 kg)	96" (2.44 m)	40" (1.02 m)	55.7" (1.41 m)	123.8 cu.ft (3.51 cu.m)

NOTE: Gross weight may vary ... unit weights can change depending on options ordered.

2. Installation

This section summarizes procedures necessary for proper installation of your new unit. To prevent personal injury or damage to the equipment, please ensure the following steps are followed.

2.01 Location



• **DO NOT MODIFY, ALTER OR ADD UNAUTHORIZED ATTACHMENTS TO THIS EQUIPMENT**

1. Keep the appliance and surrounding area free and clear of combustible materials; maintain 3 in. (7.6 cm) clearance.
2. Please note the wiring diagram provided with this appliance. Ensure that it corresponds with the equipment being installed.
3. Please ensure this appliance is electrically grounded in accordance with local codes, or in the absence of local codes, with the National Electrical Code, ANSI/NFPA NO. 70-1999.
4. Please provide adequate room for proper operation and servicing of the appliance.
5. Provide adequate ventilation in the operating area in compliance with local codes.
6. Always consult with an electrician or other qualified technician prior to installation.
7. Ensure that the voltage and amperage rating of the supply circuit meet the specifications indicated on the Fryer's data plate/label.
8. Locate the unit in a secure position and ensure that it will not unintentionally move. The unit is equipped with locking casters ... please use them!
9. This appliance is to be installed, operated, and maintained in accordance with the Standard for Ventilation Control and Fire Protection of Commercial Cooking Operations, NFPA 96-1994.

Compliance with the above items will help to ensure safe and proper installation. If you have any questions concerning these procedures, contact a Giles Representative or other qualified service agency.

2.02 Unpacking

The Giles Fryer is shipped as a palletized unit. It is secured to a wooden skid by high-tensile strength plastic strapping and wrapped by machine applied stretch-wrap.

CAUTION

- Exercise care when lifting or moving the palletized unit, and when removing packing materials or removing unit from the shipping skid.
- Failure to comply with these **CAUTION** notices may result in minor to moderate personal injury, damage to equipment or property, and void the warranty.

NOTE:

- If there is evidence of damage to the palletized load, immediately inspect the equipment and all accessories, and notify the freight company of any damages. Make a note of damages on the freight bill. Giles' responsibility for damages to the unit ended when the freight company's agent signed for the freight at the time of shipment.

1. Carefully cut and remove the plastic stretch wrap, strapping and all other packing material.
2. Carefully remove Fryer from the shipping skid. Fryers are very heavy, especially when in "banked" configurations. It is advisable to use appropriate material handling equipment when lifting unit from the skid, particularly when handling "banked" units of three (3) or more fryers.

NOTE:

- Giles shall not be liable for damages caused to the unit by improper use of material handling equipment or poor work practices. Giles shall not be liable for personal injuries or property damage which may be incurred during installation of this equipment. Installation is the sole responsibility of the purchaser, unless previous arrangements have been made in writing.

2.03 Electrical Requirements

CAUTION

- Fryers must be adequately and properly grounded. Improper grounding may result in electrical shock. Always refer to local electrical codes for proper grounding procedures on this or any other electrical equipment. Always consult with an electrician or other qualified service person to ensure circuit breakers and wiring are of sufficient rating and gauge for the equipment being installed.

GBF Series Fryers are available from the factory to operate with the voltages and phases listed below. Check the rating label/plate on the rear panel to determine the correct supply power requirement.

Each fryer unit of a banked battery, requires separate power service.

2.04 Electrical Specifications (per Fryer Unit)

Voltage	Phase	Hz	Watts	Amps			Circuit Breaker Required
				L1	L2	L3	
208 ⁺	3	60	18,250	53	53	50	65
208	3	60	18,000	50	50	50	60
240 ⁺	3	60	18,250	46	46	43	55
240	3	60	18,000	43	43	43	50
380 ⁺	3	50	16,720	43	43	40	50
380	3	50	16,485	41	41	41	45
415 ⁺	3	50	18,250	46	46	43	55
415	3	50	18,000	43	43	43	50

⁺ Denotes fryer unit which powers the filtration pump.

2.05 Electrical Connections

NOTE: Electrical installation materials (disconnects, breakers, conduit, connectors, wire, etc) shall be supplied by the purchaser.

1. Install appropriate circuit breaker(s) in Main Breaker Box! See **Section 2.04**.
2. (Recommended) Install a Quick-Disconnect between Main Box and Fryer; connect using flexible conduit.
3. Connect flexible conduit from Quick-Disconnect through Fryer back panel to the Fryer Service Box at the front of unit. Allow enough conduit slack so that the Fryer can be moved to provide clearance for cleaning or service. See **Figure 2.05.1**.
4. Open Fryer door and remove Service Box Cover. See **Figure 2.05.1**.
5. Connect a ground wire between the Ground Lug and a proper earth ground.
6. Route appropriately sized supply power wires to the Fryer.
7. Connect the supply power wires at the Distribution Block located in the Service Box. See **Figure 2.05.1**.
8. Reinstall Service Box Cover.
9. For “banked” installations, each Fryer in the battery will be connected in like manner.

2.05.1 Electrical Connections Diagram

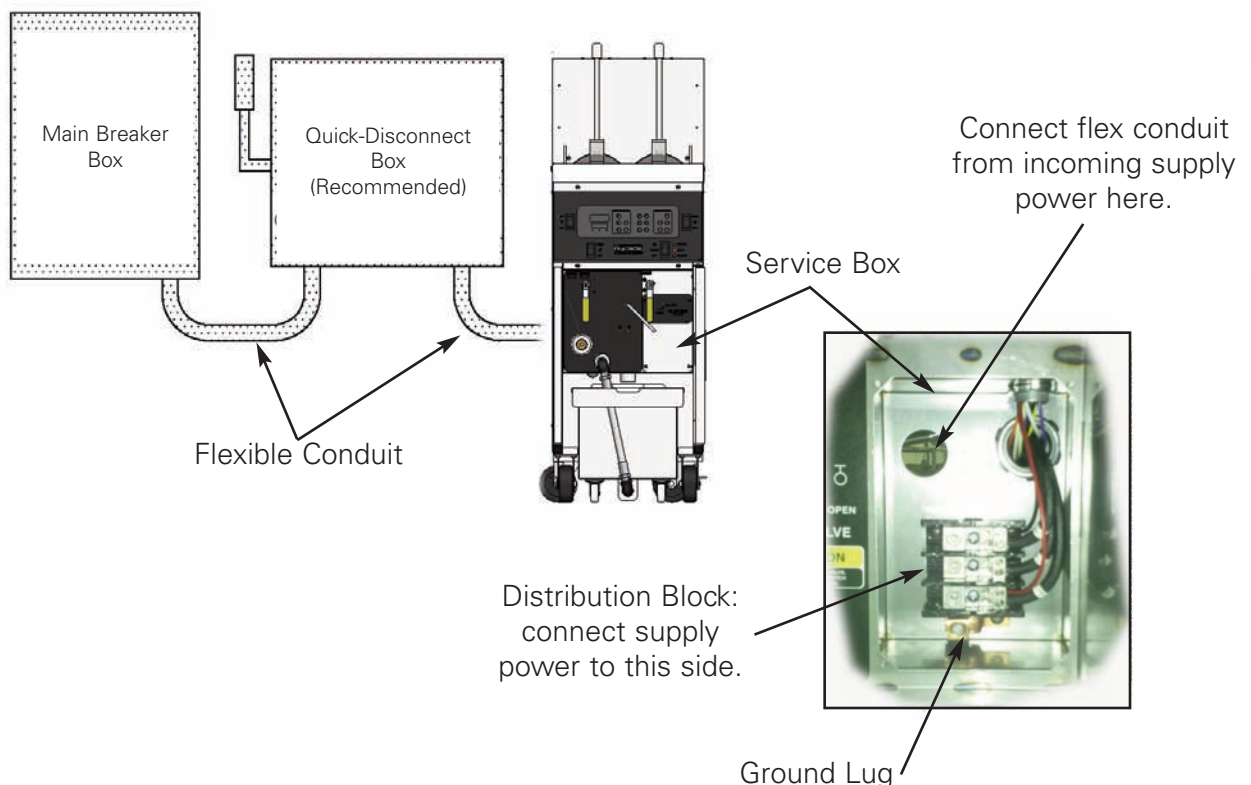

2.06 Ventilation of Fryer

NOTE:

- **Ventilation system requirements for commercial foodservice establishments differ from location to location. Always consult with local authorities to ensure proper compliance.**

Consult a professional ventilation or HVAC company for assistance in determining whether existing systems are sufficient to accommodate this equipment, or in designing a ventilation hood system to comply with code requirements.

2.07 Restraint Device (Not Included)

This equipment requires installation of an appropriate Restraint Device to prevent unintentional movement, which might cause undue strain on electrical connections. The length of Restraint Cable must be shorter than the electrical supply cord or conduit. A restraint anchor shall be fastened to a non-movable wall or structure. Use a quick-release latch on one end of the Cable for connecting to the factory-installed Eye Bolt(s) on the rear of the unit. This can easily be disconnected during maintenance or service. "Banked" systems require a Restraint Device on each end of the banked battery.

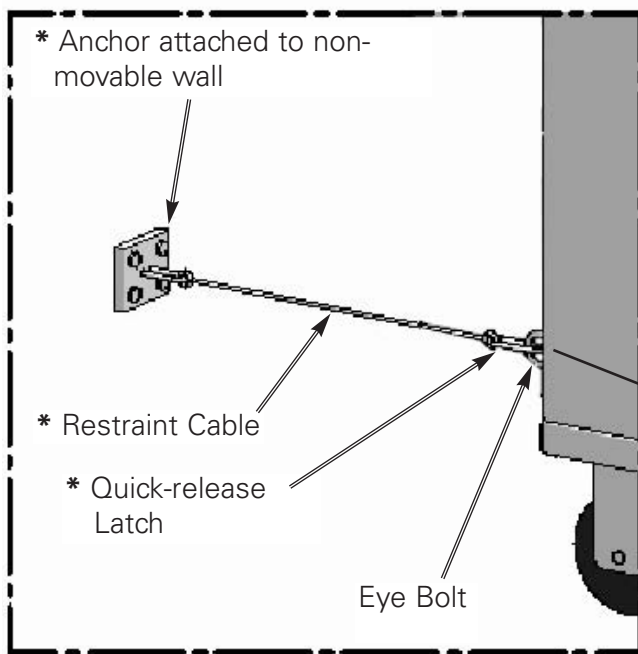

* Customer Supplied



Notes:

3. Overview

The following section gives a brief overview of the components, functions, and accessories of the GBF Series Fryer. Please review this section carefully before proceeding further.



3.01 Auto-Basket Lifts (Optional) & Baskets

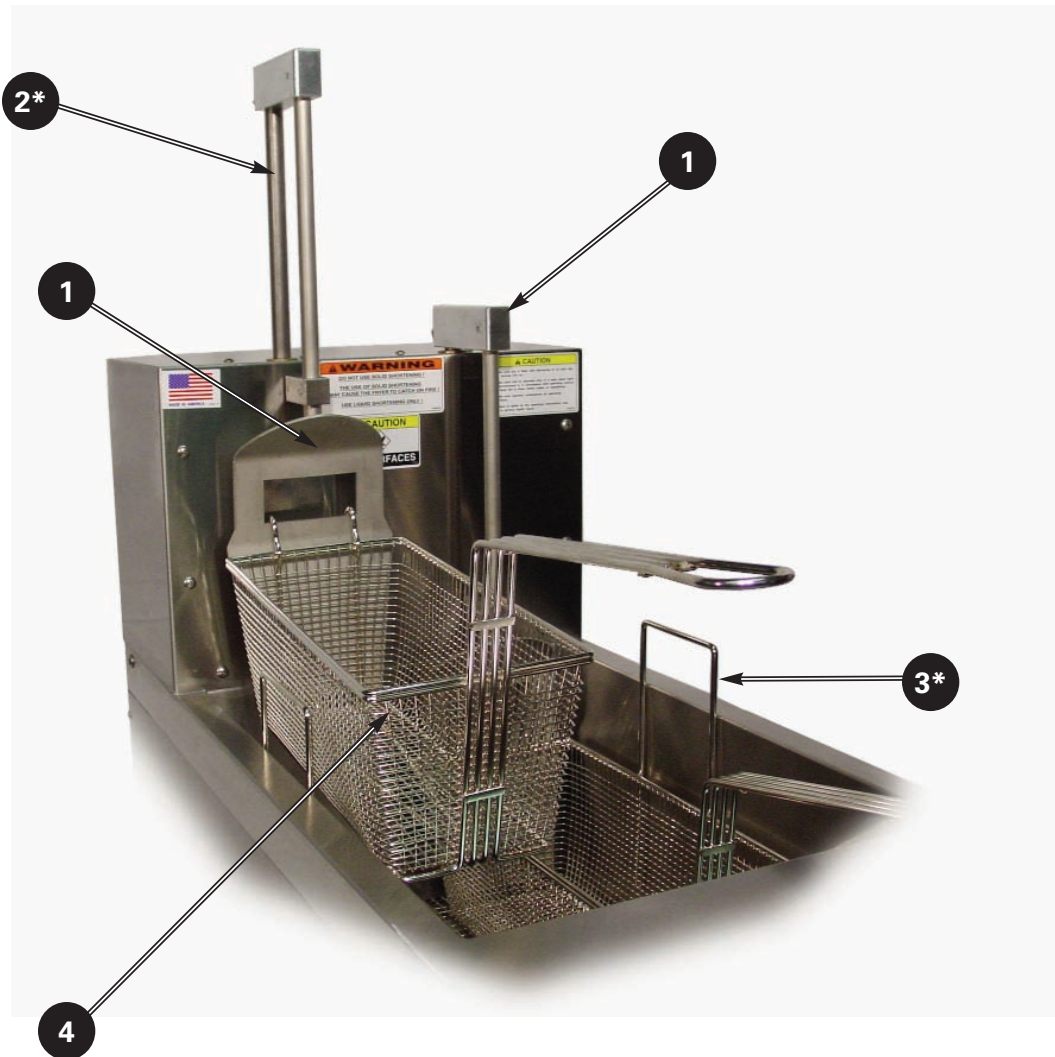

* Not fully seen

⚠ CAUTION

- Always use Thermal Oven Mitts when handling any of these parts during normal operations; they can become very hot!

3.01 Auto-Basket Lifts (Optional) & Baskets

Item	Description	Function
1	Basket Carrier (2)	Holds basket in a proper position while it is being lifted from or lowered into the cook vat by the Basket Lift.
2*	Auto-Basket Lift (2)	Lowers or lifts basket at beginning and end of cook cycle.
3*	Basket Support/ Fry Screen	Provides support surface for Baskets when Auto-Lifts are not installed or used. Serves as a Fry Screen to prevent excessive crumbs and cooking residue from accumulating around the heating elements.
4	Basket (2)	Contains product during cooking.

* Not fully seen

3.02 Control Panel

3.02.1 Control Panel - Computer Controller (N7)



* NOTE: Switch location will be plugged if not required.

3.02.1 Control Panel - Computer Controller (N7)

Item	Description	Function
1	Power Switch	Main Power Switch ... turns Fryer power on or off.
2	Heat Switch	Heat Switch turns power to heating elements on or off. Place in OFF position when programming controller or shutting down. Place in the HEAT position when ready to heat for cooking or boil-out.
3	Controller	Micro-processor Cooking Controller ... set cooking temperature and cook times ... controls and monitors fryer functions ... displays alarm conditions.
4	Programmable Basket Timer (Right & Left Basket)	Two (2) programmable basket timers ... each holds four (4) different cook cycles ... menu keys for one-touch selection.
5	Power Indicator Light (Green)	The Power indicator is illuminated whenever the Fryer's main Power Switch is in the ON position.
6	Heat Indicator Light (Amber)	The Heat indicator is illuminated when the Heat Switch is in the HEAT position and the heating elements are energized. This light will cycle on and off during normal operation as the Controller maintains oil at the set-point temperature.
7	High-Limit Indicator (Red)	The High-Limit indicator is illuminated to alert of power shutdown to the heating elements due to an overheating condition. Should this light turn on during operation, DISCONTINUE COOKING ACTIVITY and refer to Troubleshooting, Section 7 of this manual. DO NOT ATTEMPT TO CONTINUE COOKING UNTIL THE CAUSE OF THIS CONDITION IS DETERMINED!
8*	Pump Switch	Controls the Oil Filtration System pump for filtering oil or pumping used oil to the Oil Discharge Hose. NOTE: This switch is only present on the Fryer unit that houses the Filter Pan for "Banked" systems.
9*	Basket Lift Switch (Optional)	Enables or disables Basket Lifts. In the LIFT position, lift will lower when a cook cycle starts and be raised when cook time expires. In the OFF position, both lifts are disabled and will not operate. NOTE: This switch is present only if the Basket Lift option is installed.

3.02.2 Control Panel - Mechanical Controls

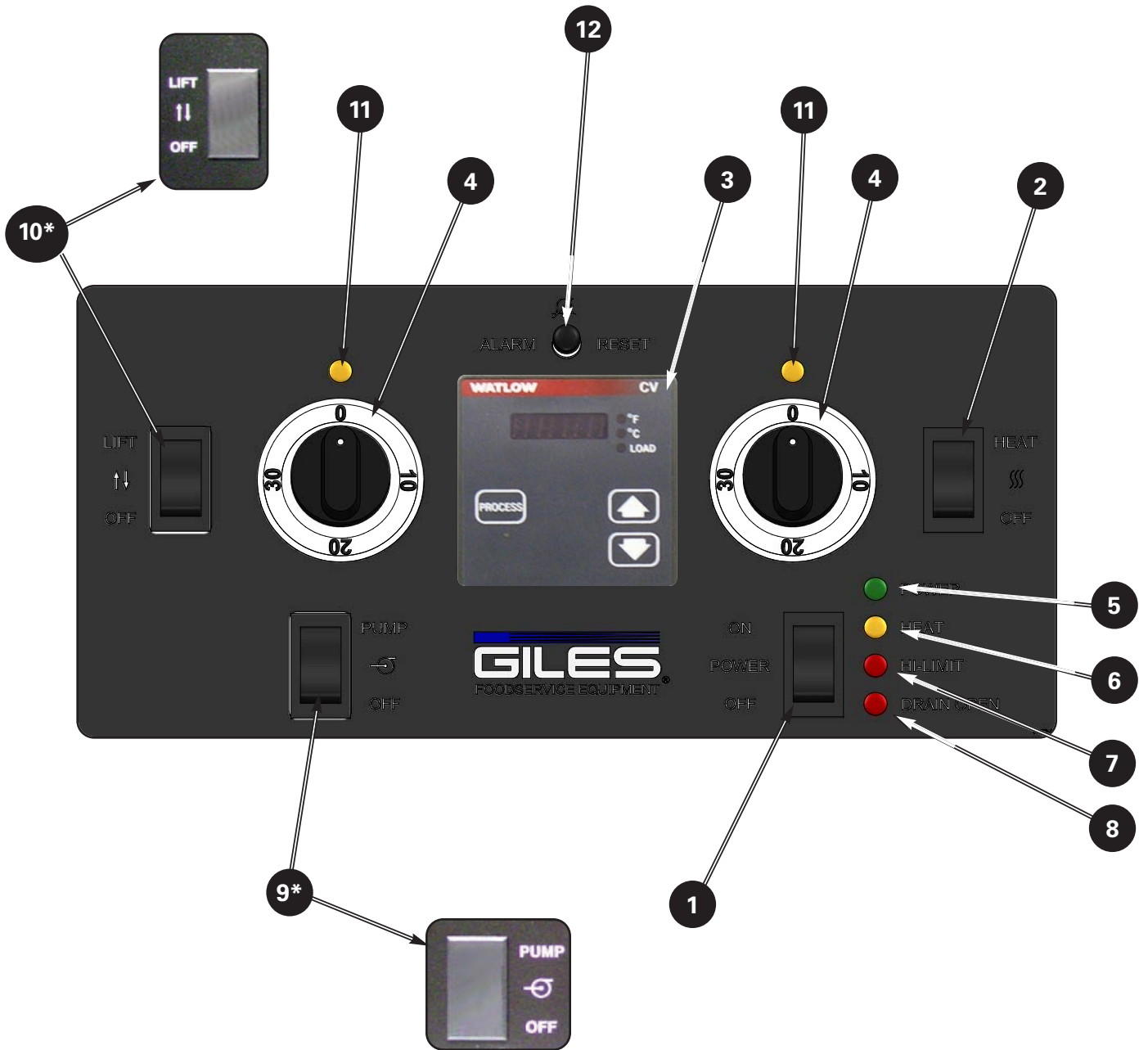



* NOTE: Switch location will be plugged if not required.

3.02.2 Control Panel - Mechanical Controls		
Item	Description	Function
1	Power Switch	Main Power Switch ... turns Fryer power on or off.
2	Heat Switch	Heat Switch turns power to heating elements on or off. Place in the HEAT position when ready to heat for cooking or boil-out. Place in OFF to shutdown elements.
3	Digital Temperature Control (Thermostat)	Digital thermostat is used to set and control temperature of the cooking oil. Displays actual temperature when PROCESS key is pressed.
4	Mechanical Basket Timer (Right & Left Basket)	Two (2) eletro-mechanical basket timers, 30 minute range.
5	Power Indicator Light (Green)	The Power indicator is illuminated whenever the Fryer's main Power Switch is in the ON position.
6	Heat Indicator Light (Amber)	The Heat indicator is illuminated when the Heat Switch is in the HEAT position and the heating elements are energized. This light will cycle on and off during normal operation as the Controller maintains oil at set point temperature.
7	High-Limit Indicator (Red)	The High-Limit indicator is illuminated as an alert to power shutdown to the heating elements due to an overheating condition. Should this light turn on during operation, DISCONTINUE COOKING ACTIVITY and refer to Troubleshooting, Section 7 of this manual. DO NOT ATTEMPT TO CONTINUE COOKING UNTIL THE CAUSE OF THIS CONDITION IS DETERMINED!
8	Drain Open Indicator (Red)	The Drain Open indicator is illuminated if the cook vat drain valve is not fully closed. Fryer will not heat if drain valve is not fully closed.
9*	Pump Switch	Controls the Oil Filtration System pump for filtering oil or pumping used oil to the Oil Discharge Hose. NOTE: This switch is only present on the Fryer unit that houses the Filter Pan for "Banked" systems.
10*	Basket Lift Switch (Optional)	Enables or disables Basket Lifts. In the LIFT position, lift will lower when a cook cycle starts and be raised when cook time expires. In the OFF position, both lifts are disabled and will not operate. NOTE: This switch is present only if the Basket Lift option is installed.
11	Cycle End Indicator (Amber)	Illuminates to indicate which Basket Timer has completed a cook cycle - audible alert also sounds.
12	Alarm Reset Button	Pressing silences audible alert alarm.

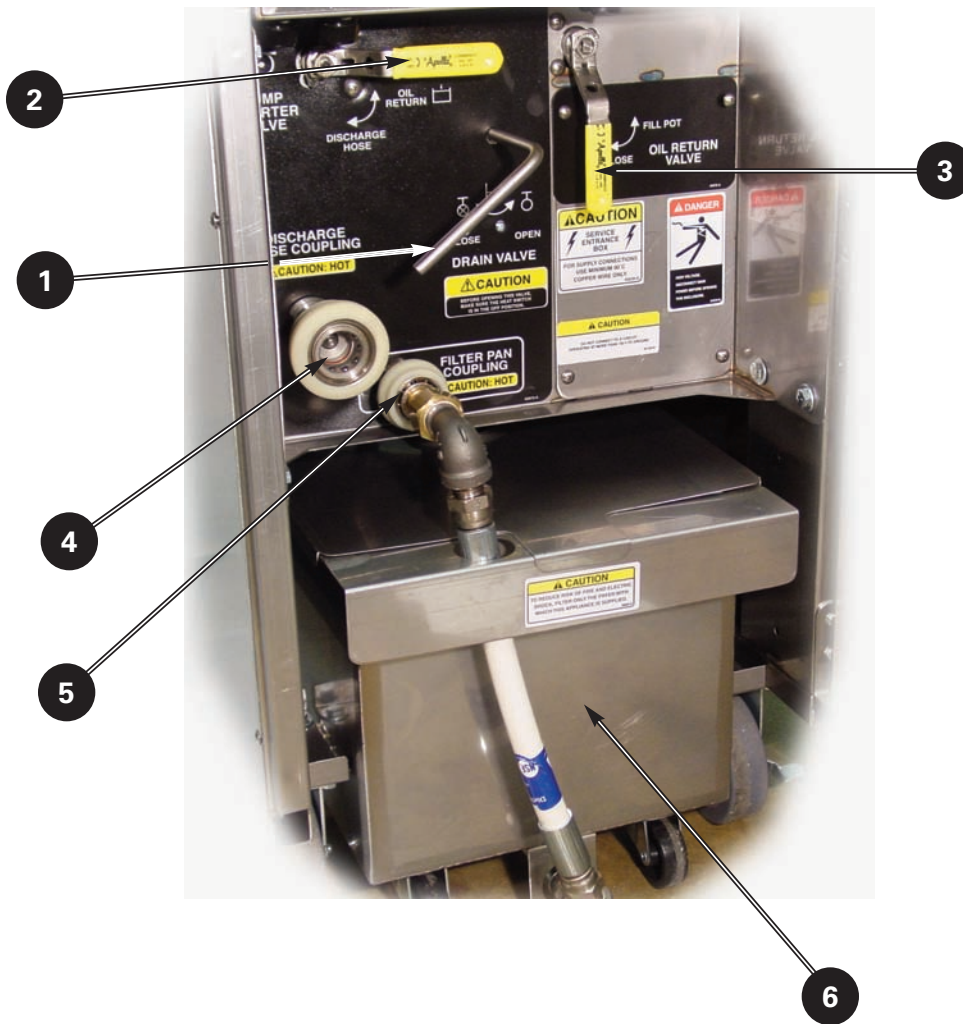
3.03 Lower Cabinet Area - Single Fryer & Base Unit of "Banked" Systems





3.03 Lower Cabinet Area - Single Fryer & Base Unit of "Banked" Systems

Item	Description	Function
1	Drain Valve Handle	<p>Opens or closes the cook vat Drain Valve. Always ensure the valve is fully CLOSED (handle in left-most position) prior to adding cooking oil or boil out solution. The fryer will not heat if the Drain Valve is not completely closed!</p> <p> DANGER Always ensure the Heat Switch on Control Panel is in the "OFF" position before opening this valve. Failure to do this could result in fire, causing death or serious injury, equipment or property damage, and void the warranty.</p> <p> WARNING "Banked" Fryer systems - NEVER drain oil from more than one (1) Fryer at a time into the Filter Pan. Doing so will cause the Filter Pan to OVERFLOW! Always pump oil from Filter Pan back a Fryer vat or to an oil disposal container before draining oil from another vat.</p>
2	Pump Diverter Valve Handle	Directs discharge of Filter Pump to either return oil from Filter Pan to a Fryer vat or send it to the Oil Discharge Hose (hose must be connected to Fryer before doing this).
3	Vat Fill Valve Handle	Opens or closes the fry vat Oil Return Valve allowing vat to be refilled with filtered oil from the Filter Pan. Pump Diverter Valve must be positioned to " OIL RETURN "
4	Oil Discharge Hose Connection	Quick-disconnect fitting to connect the Oil Discharge Hose to the Fryer's filter system for removing used oil.
5	Filter Pan Connection	Quick-disconnect fitting to connect the Filter Pan Assembly to the Fryer's filter system.
6	Filter Pan Assembly	Holds cooking oil when drained from vat and contains filter media for filtering the oil.

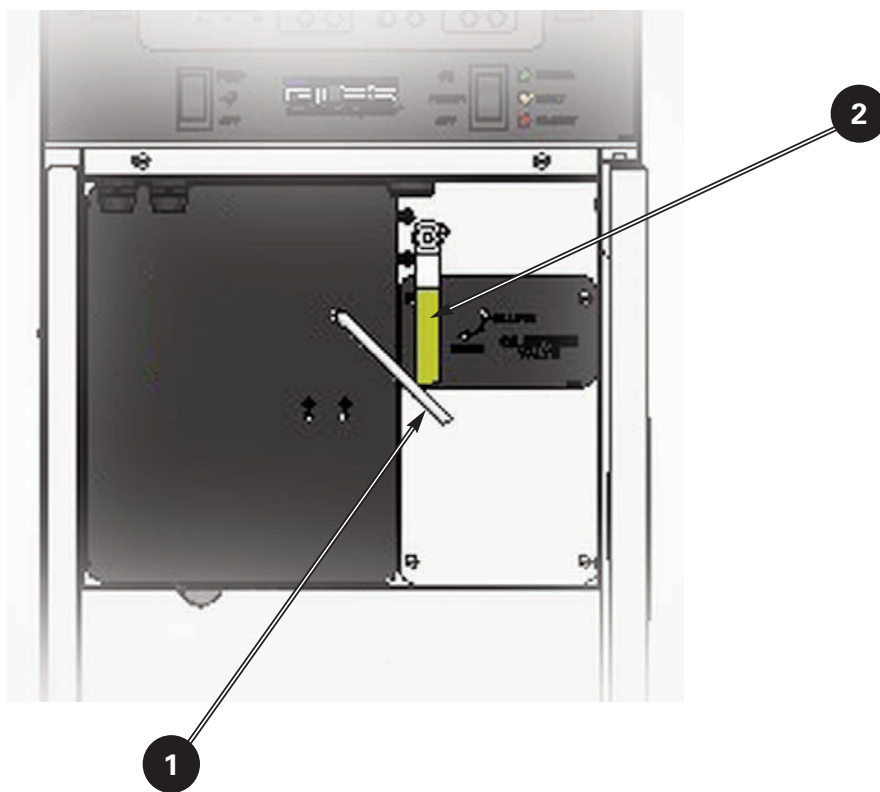
3.04 Lower Cabinet Area: Add-on Fryers for "Banked" Systems



3.04 Lower Cabinet Area: Add-on Fryers for “Banked” Systems

Item	Description	Function
1	Drain Valve Handle	<p>Opens or closes the cook vat Drain Valve. Always ensure the valve is fully CLOSED (handle in left-most position) prior to adding cooking oil or boil out solution. The fryer will not heat if the Drain Valve is not completely closed!</p> <p> DANGER Always ensure the Heat Switch on Control Panel is in the “OFF” position before opening this valve. Failure to do this could result in fire, causing death or serious injury, equipment or property damage, and void the warranty.</p> <p> WARNING “Banked” Fryer systems - NEVER drain oil from more than one (1) Fryer at a time into the Filter Pan. Doing so will cause the Filter Pan to OVERFLOW! Always pump oil from Filter Pan back a Fryer vat or to an oil disposal container before draining oil from another vat.</p>
2	Vat Fill Valve Handle	<p>Opens or closes the fry vat Oil Return Valve allowing vat to be refilled with filtered oil from the Filter Pan. Pump Diverter Valve must be positioned to “OIL RETURN”</p>

3.05 Filter Pan Unit: Single Fryer & Base Unit of "Banked" Systems

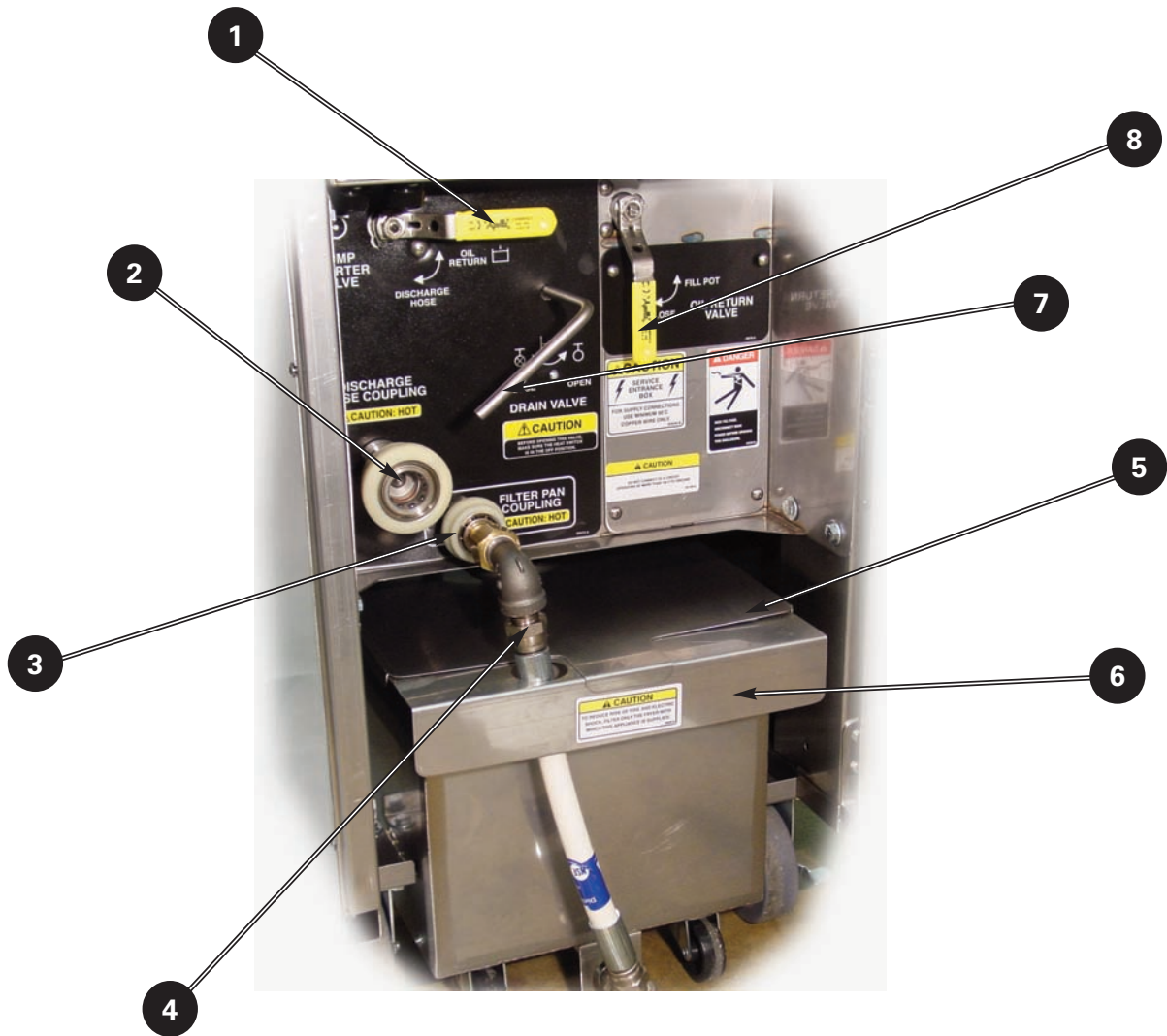

3.05 Filter Pan Unit: Single Fryer & Base Unit of “Banked” Systems

WARNING

- Never remove the Filter Pan while it contains HOT liquid shortening. Oil spillage and/or burn injury are possible. Please see Section 5.04, Removal of Liquid Shortening.

CAUTION

- Always use Thermal Oven Mitts, these parts can become very HOT during normal operations!
- Never drain boil-out solution into the Filter Pan. It is corrosive and will damage the Filter Pan, its components, and the Filter Pump. See Section 6.01, Boil-Out Procedure.

Item	Description	Function
1	Pump Diverter Valve Handle	See Section 3.03
2	Oil Discharge Hose Connection	Quick-disconnect fitting used to connect the Oil Discharge Hose to the Fryer’s filter system.
3	Filter Pan Connection	Quick-disconnect fitting used to connect the Filter Pan Assembly to the Fryer’s filter system.
4	Filter Pan Quick-Disconnect Hose	See Section 3.06
5	Filter Pan Cover	Helps prevent possible contaminating foreign material or substances from entering Filter Pan.
6	Filter Pan	See Section 3.06
7	Drain Valve Handle	See Section 3.03
8	Vat Fill Valve Handle	See Section 3.03

3.06 Filter Pan Assembly

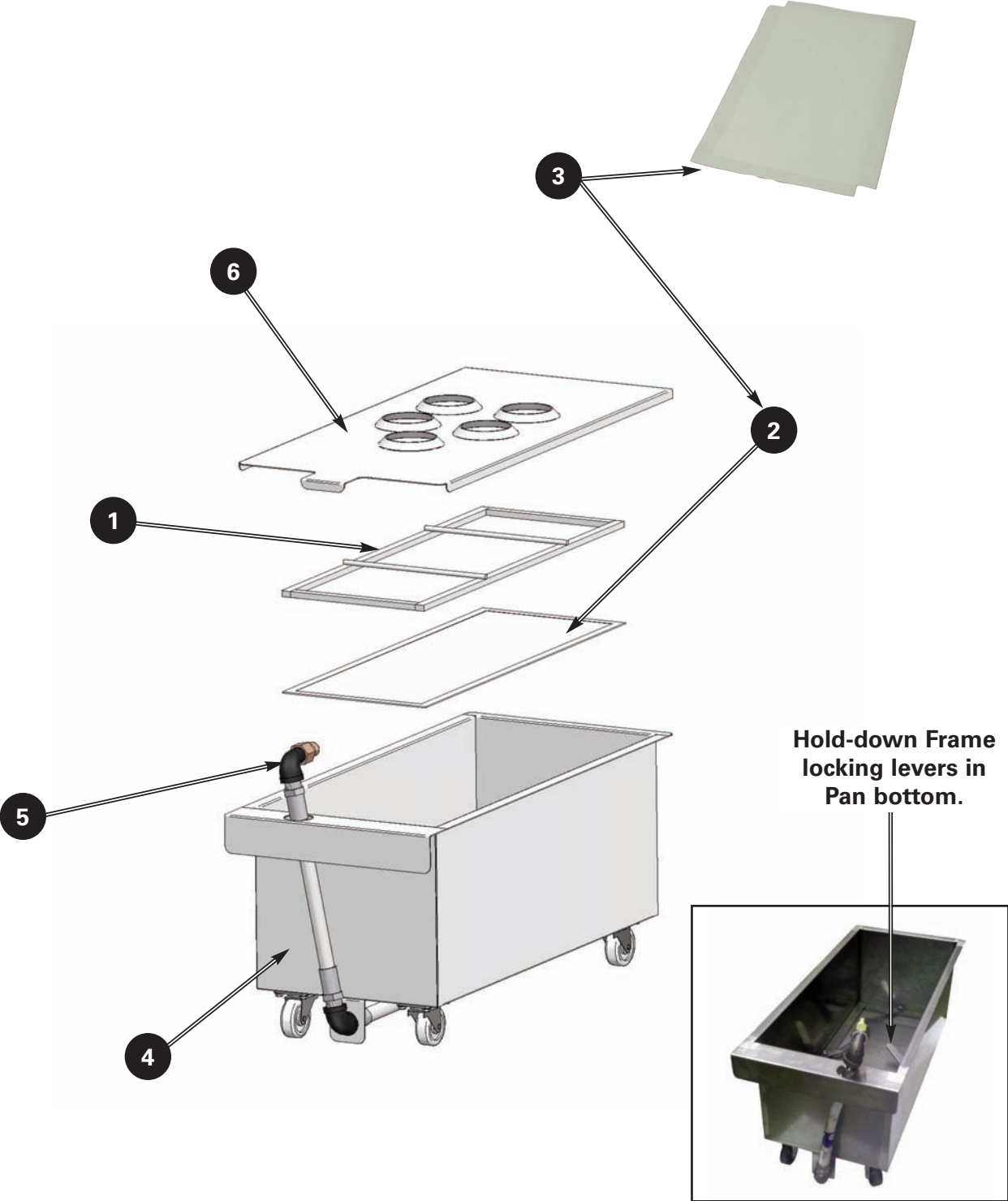

3.06 Filter Pan Assembly





WARNING



- Never remove the Filter Pan while it contains liquid shortening. Oil spillage and/or burn injury are possible. Please see Section 5.04, Removal of Liquid Shortening.

CAUTION



- Always use Thermal Oven Mitts, these parts can become very HOT during normal operations!
- Never drain boil-out solution into the Filter Pan. It is corrosive and will damage the Filter Pan and components, and the Filter Pump. See Section 6.01, Boil-Out Procedure.

Item	Description	Function
1	Hold Down Frame	Holds & seals filter media tightly against Filter Pan bottom to create the proper suction seal for the Filter Pump.
2	Reusable Micro-Mesh Stainless Filter Screen (Standard)	Stainless steel, micro-mesh screen filter media removes fine particles of cooking sediment and residue from liquid shortening. It is washable and reusable; eliminates paper waste and reduces operating cost.
3	Filter Paper (Optional)	Paper filter media may be used (in lieu of screen). One (1) sheet is required ... two (2) sheets may be used, if desired.
4	Filter Pan	Holds and filters oil drained from fry vat (recommend to filter after every four (4) loads cooked). The Filter Pan features casters and is easily removable for cleaning. A permanent perforated screen is affixed to the pan bottom to support the filter media and aid in protecting the filter pump from unintended large debris. THIS IS NOT A FILTER ... FILTER MEDIA MUST BE USED!
5	Filter Pan Quick-disconnect	Fitting for connecting Pan Assembly to the fryer filtration system. Hose must be disconnected before removing the filter pan.
6	Filter Pan Cover	Helps prevent possible foreign material contamination of cooking oil during various operations. Fits top of Pan.

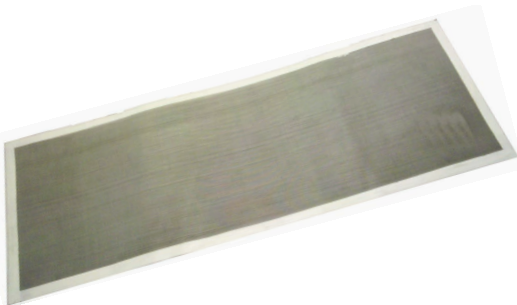
3.07 Accessories (Included)		
Part	Description/Part Number	Function
	Kettle Drain Brush P/N: 71025	Use to clean the Fry Vat Drain and other parts.
	L-Shaped Brush P/N: 93609	Use to clean between and around heating elements.
	Teflon Cleaning Brush P/N: 71100	Multi-purpose, use to clean Fry Vat sides, bottom and heating elements.
	Crumb Shovel P/N: 30059	Use to remove sediment from the Filter Pan.

3.07 Accessories (Included)		
Part	Description/Part Number	Function
	<p>Oil Discharge Hose P/N: 33667</p>	<p>Use to discharge used liquid shortening to a disposal container when removing from the Fryer.</p> <p>Note: Not intended for washing down fry vat!</p>
	<p>Basket 13-1/4" x 6-1/2" x 6" P/N: 41040</p>	<p>Use to contain product for cooking. Vat accommodates (2) Baskets.</p>
	<p>Basket Support/Fry Screen P/N: 41041 (1) per vat</p>	<p>Supports baskets while cooking and prevents excessive crumbs or residue from accumulating around heating elements.</p>
	<p>Micro-Mesh Filter Screen P/N: 41078</p>	<p>Reusable stainless steel filter media for use in the Filter Pan to clean cooking oil as it is circulated through Filtration System.</p>

3.08 Accessories (Not Included)

Part	Description/Part Number	Function
 <p>A stainless steel oil disposal container with a pump handle and hose.</p>	<p>Giles Oil Caddy P/N: 79187</p>	<p>A portable oil disposal container with capacity to hold 80 lbs. of liquid waste shortening.</p> <p>Note: For use with filtered, warm oil only (no crumbs or debris).</p>
 <p>A box of white paper filter media.</p>	<p>Filter Paper P/N: 65871</p>	<p>Paper filter media for use in the Filter Pan to clean cooking oil when it is circulated through Filtration System.</p> <p>Use in lieu of reusable mesh filter screen.</p>
 <p>A box of white filter powder.</p>	<p>Filter Powder P/N: 72004</p>	<p>Filtering aid used during the oil filtration process.</p>

3.08 Accessories (Not Included)		
Part	Description/Part Number	Function
	Fryer Boil-Out P/N: 72003	Add to water in the Fry Vat to make up boil-out solution for cleaning the cook vat.



Notes:

4. Unit Preparation

Giles Enterprises takes pride in the quality of its workmanship. Each unit has passed rigorous quality control testing prior to shipment and every effort has been made to ensure that the equipment will be in good operating condition when received. To further ensure a trouble-free start-up, a brief operational check-out should be performed as described in this section.

CAUTION

- Before attempting to operate the Fryer, please refer to Section 3 to become familiar with the various controls and their function. After you have read and fully understand Section 3, please follow the steps below precisely to prevent possible equipment damage or malfunction.

4.01 Set-up Fryer(s) for Check-out

Please ensure Fryer(s) Control Panel switches and Lower Cabinet valves are set as follows before proceeding to each test. If you have purchased a “banked” battery of fryers, these checks should be performed for each unit.

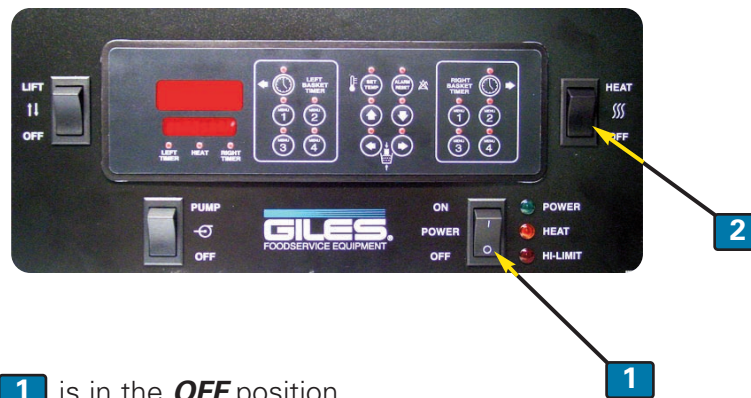

1. Power Switch **1** is in the **OFF** position.
2. Heat Switch **2** is in the **OFF** position.

NOTE: On “banked” systems, each Fryer in the battery must be set accordingly.

4.01 Set-up Fryer(s) for Check-out (continued from previous page)

3. Open cabinet door(s), disconnect and remove Filter Pan Assembly from unit.
4. Ensure that the Drain Valve Handle(s) **3** is in the fully **CLOSED**, left-most, position ... **check all fryer units in a "banked" battery.**
5. Ensure the Pump Diverter Valve **4** is in the **OIL RETURN** position (horizontal) and the Oil Fill Valve **5** is in the **FILL VAT** position (horizontal).
6. Remove Baskets and Basket Support/Fry Screen(s).

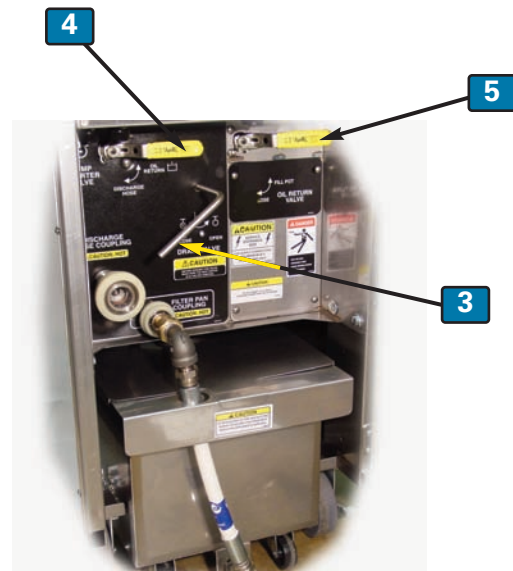

NOTE: On "banked" systems, the Pump Diverter Valve **4** is only present in the cabinet containing the Filter Pan.

4.02 Power Check

The following check will confirm that the unit has power. **Perform this check for each unit in a “banked” system.**



1. Follow steps previously described in **Section 4.01**.
2. Confirm that the main circuit breaker(s) supplying power the unit(s) is **ON**. If a Disconnect Switch Box is installed between the breaker(s) and Fryer(s), confirm that it is in the **ON** position.
3. Set the Power Switch **1** to the **ON** position. The green POWER light **2** will illuminate. Proceed to Section 4.03.

If the POWER light does not turn on, refer to **Section 7.01, Troubleshooting Procedures**.

4.03 Heating Element Check

The following check will confirm that Heating Elements are being powered and properly energized. **Perform this check for each Fry Vat in a “banked” system.**



The Heating Elements become extremely hot when energized! Any skin contact with them may result in severe burns.

4.03.1 Heating Element Check - Computer Controller

1. Follow steps previously shown in **Section 4.01**.
2. Confirm Power Switch **2** is in the **OFF** position.
3. Liberally dampen a sponge with water and wipe down Heating Elements **1** leaving them visibly moist.
4. Set the Power Switch **2** to the **ON** position.
5. Wait until the Controller powers up and the display **3** reads **“HOLD”**.
6. Press the Set Temp **4** button ... the displayed value should be greater than **300°F**. If not, set temperature set-point to a value of **300°F** or higher (see **Section 5.01.2, Programming Cooking Temperature** for instructions).
7. Set the Heat Switch **5** to the **HEAT** position. The **HEAT** light **6** should turn on. Leave switch in the **HEAT** position **NO MORE THAN 10 to 12 SECONDS**.

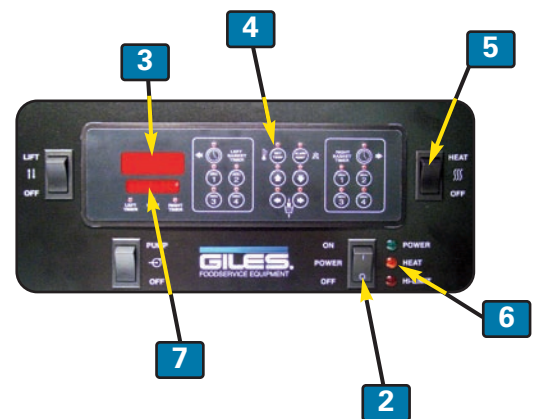
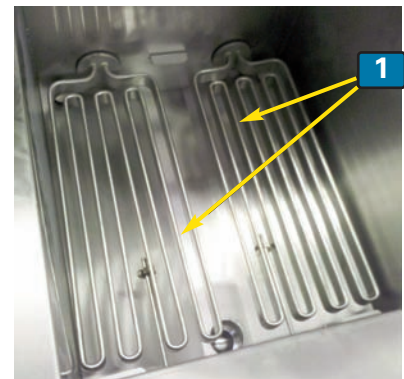

Note: During this time, should the **HEAT** light turn off, an alarm sound and the Scrolling Display **7** read **“Check Oil Level”**; return Power Switch **2** to the **OFF** position and proceed to the next step.

Continued next page

4.03.1 Heating Element Check - Computer Controller (continued from previous page)

8. Return Heat Switch **8** to the **OFF** position
9. Moisture should quickly dry from elements and heat should be felt rising from the vat. ***DO NOT AT ANY TIME TOUCH THE ELEMENTS DURING THIS CHECK!***
Proceed to **Section 4.04** below.

If Heating Elements do not dry and no heating is felt within 15 - 30 seconds, refer to **Section 7.01, Troubleshooting Procedures**.



4.03.2 Heating Element Check - Mechanical Controls



The Heating Elements become extremely hot when energized! Any skin contact with them may result in severe burns.

1. Follow steps shown in **Section 4.01**.
2. Confirm Power Switch **2** is in the **OFF** position.
3. Liberally dampen a sponge with water and wipe down Heating Elements **1** leaving them visibly moist.
4. Set the Power Switch **2** to the **ON** position.
5. The temperature set-point value displayed on the Digital Thermostat **9** should be greater than **300°F**; if not, change the setting to a value of **300°F** or higher (see **Section 5.01.2, Programming Cooking Temperature** for instructions).
7. Set the Heat Switch **5** to the **HEAT** position. The **HEAT** light **6** should turn on.
Leave switch in the **HEAT** position **NO MORE THAN 10 to 12 SECONDS**.



Continued next page

4.03.2 Heating Element Check - Mechanical Controls (continued from previous page)



The Heating Elements become extremely hot when energized! Any skin contact with them may result in severe burns.

- 8. Return Heat Switch **5** to the **OFF** position
- 9. Moisture should quickly dry from elements and heat should be felt rising from the vat. ***DO NOT AT ANY TIME TOUCH THE ELEMENTS DURING THIS CHECK!***
Proceed to **Section 4.04**.

If Heating Elements do not dry and no heating is felt within 15 - 30 seconds, refer to **Section 7.01, Troubleshooting Procedures**.



4.04 Filter Pump Check

The following check is to confirm that the system Filter Pump is operating correctly.

1. Follow steps shown in **Section 4.01**.
2. Open Cabinet Door (unit containing Filter Pan connection for "banked" systems). **Disconnect and remove Filter Pan if not previously done.**
3. Firmly press the palm of your hand over the Filter Pan Quick- Disconnect **1** opening.
4. While covering the opening with the hand, set the Pump Switch **2** to the **PUMP** position. The pump should start ... if suction is felt on your hand, it is operating correctly. Return switch to **OFF** ... ONLY allow pump to run long enough to check for suction. Proceed to **Section 4.05**.

If the pump does not start or suction is not detected, refer to **Section 7.02, Troubleshooting Procedures**.

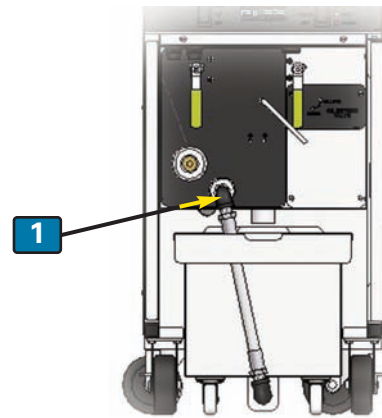

Computer Controller



Mechanical Controls

4.05 Boil-Out Procedure

Perform a Boil-Out procedure to remove dirt, dust or debris that may have accumulated in the fry vat(s) during shipping. Follow instructions in **Section 6.01, Boil Out Procedure**. After performing this procedure, proceed to **Section 4.06** below.

4.06 Clean Filter Pan

Thoroughly clean the Filter Pan Assembly to remove dirt, dust or debris that may have accumulated during shipping. Follow instructions in **Section 6.02, Cleaning Filter Pan & Replacing Filter Paper after Boil-Out**.

Fryer check-out and preparation is now complete; proceed to **Fryer Operation, Section 5**.

5. Fryer Operation

This section describes fryer operation. The GBF Series Fryer is available in with two (2) different vat sizes (50-lb & 35-lb oil cap.) and several optional configurations: single fryer, “banked” fryer battery - up to five (5) units, micro-processor computer controller, mechanical cook timers & digital thermostat, Auto-Basket Lifts, or Basket Hanger. Differences in procedures are noted where needed and, in some cases, separate sections are used to describe appropriate operational procedures for the different configurations. When becoming familiar with the Fryer operations described in this section, be certain you are referencing information or instructions pertaining to the specific Fryer configuration you have purchased.

DANGER

- Turn off Fryer power switch(es) and appropriate circuit breaker in the main circuit breaker box before cleaning or performing maintenance.
- DO NOT hose down Fryer interior or exterior with water from a spray hose.
- Failure to comply with DANGER notices will result in death or serious injury, damage to equipment or property, and will void the warranty!

CAUTION

- Ensure the unit is positioned in a secure and safe location, that the casters are locked, and that an appropriate restraint cable is installed to prevent unintended movement.
- Consult an electrician to confirm that installation meets all electrical specifications and that the unit is properly grounded. The wiring diagram provided with this manual should aid an electrician or technician during installation of the equipment.
- Due to the high temperature of oil during cooking activities, it is extremely important that the user exercise caution when operating and working with this equipment in order to avoid personal injury.
- This appliance is not intended for use by persons (including children) with reduced physical, sensory, or mental capabilities, or lack of experience and knowledge, unless they have been given adequate instruction and/or supervision concerning its use by a person responsible for their safety. Children should be supervised, or otherwise restricted, to ensure they do not play with or around this appliance.

5.01 Fryer Cooking Controls

This section explains the functions, features and operating instructions for the Fryer cooking controls. These instructions apply to the two (2) specific styles of controls available for the GBF Series: **Computer Micro-Processor Controller** or **Electro-Mechanical Controls**.

5.01.1 Computer Controller - Overview

The following sub-section provides instructions for operating and setting the **Computer Micro-Processor Cooking Controller**.

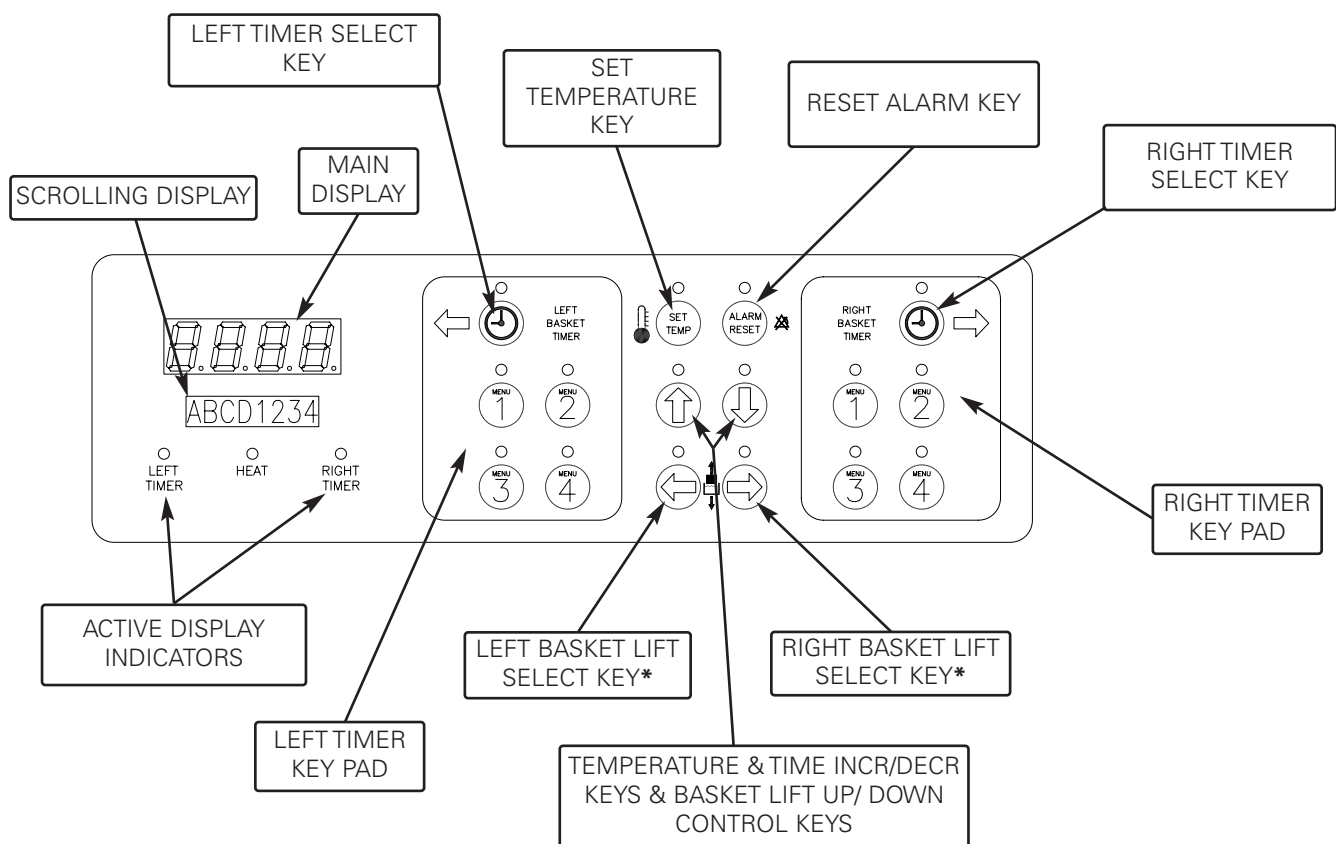

* Only active when Basket Lift Option is installed

5.01.1.1 Keys and Functions - Computer Control

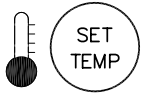

Press to initiate setting of a cooking temperature set-point, or "Press & Hold" to momentarily display actual oil temperature.

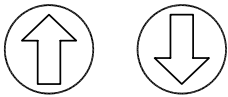

When setting temperature set-point or cook time, use to increase or decrease the displayed value. If equipped and when right or left Basket Lift is selected, these keys raise or lower the lift.

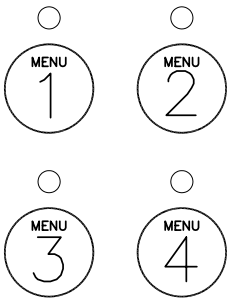

Menu item memory keys ... use when programming and storing cooking times for up to (4) different menu items, and to recall these programmed times for cooking.



Press to silence fryer alert alarm.

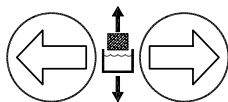

Basket Lift select key ... use to select Left or Right Basket Lift. **These keys are disabled when Basket Lift Option is not installed.**

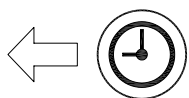

Press to select the Left Basket Timer.

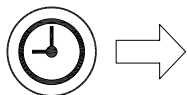

Press to select the Right Basket Timer.

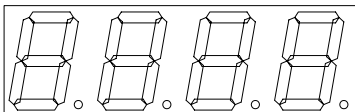

Main Control display ... displays cooking time and temperature.



Scrolling Display ... displays various status information and alarm messages.

5.01.1.2 Programming Cooking Temperature - Computer Control



Set Power Switch to **ON**

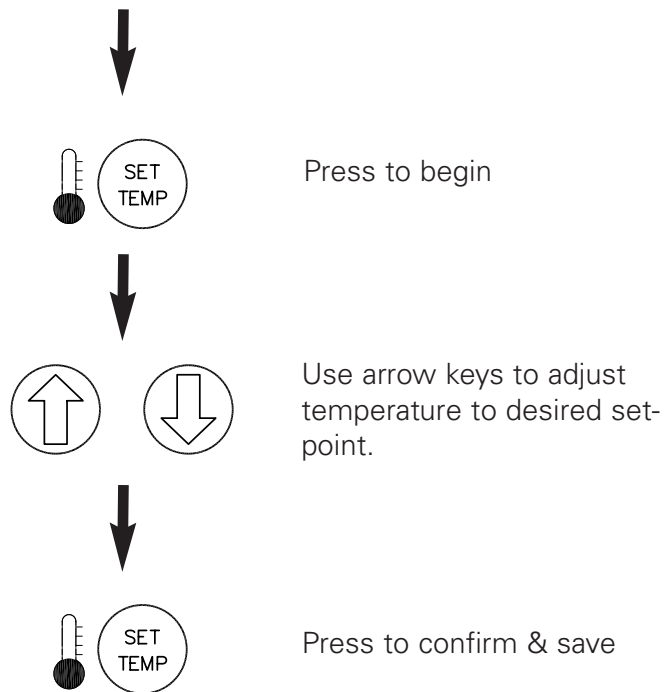

5.01.1.3 Programming Cooking Time - Computer Control

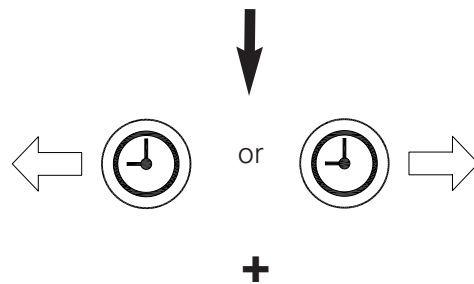

At the same time, Press & Hold both the desired Basket Timer selection key (left or right) and the desired Menu Key for 5 seconds

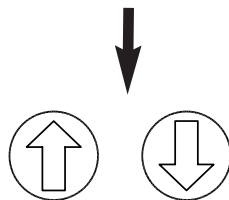
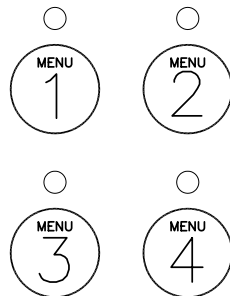

Use arrow keys to adjust cooking time (mins) to desired value.

Press the desired Basket Timer selection key again to confirm & save

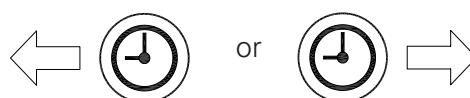

5.01.1.4 Start a Cooking Time (for cooking) - Computer Control

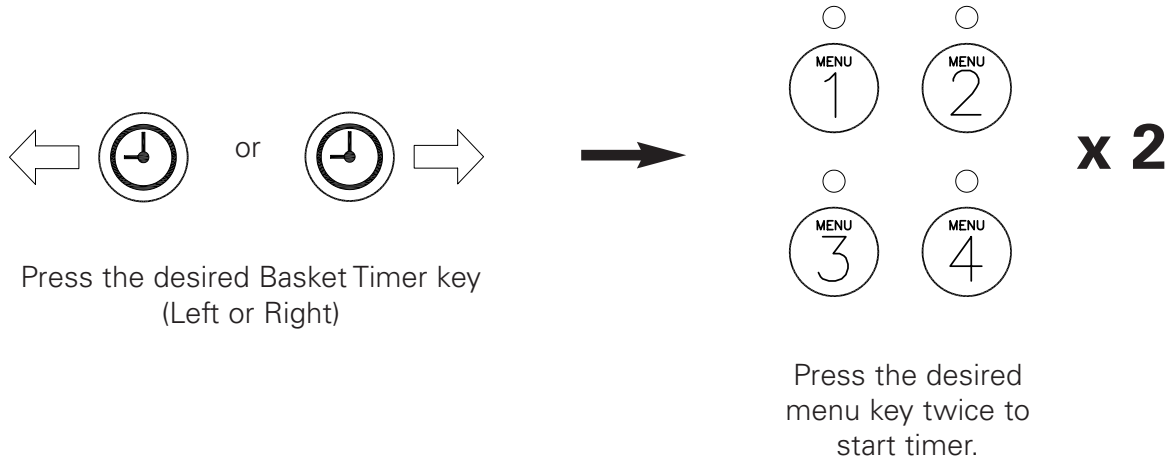

5.01.1.5 Cancel a Running Cooking Time - Computer Control

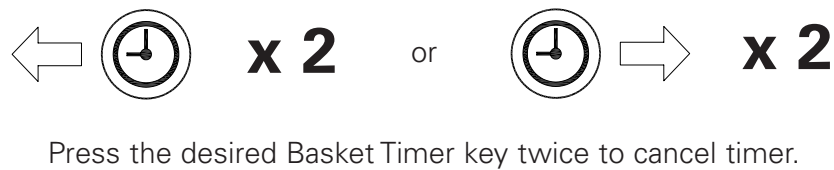

(With Basket Lift Option Only) ... If Basket Lift has already been lowered, it will be raised when timer is cancelled.

5.01.1.6 Manually Lowering & Raising the Cook Baskets (Basket Lift Option Only) - Computer Control

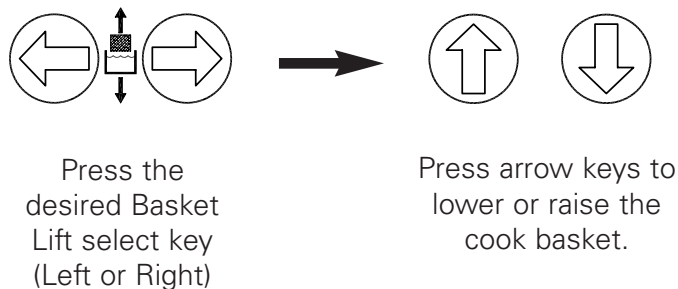

5.01.1.7 Display Cook Time Remaining - Computer Control

Active Menu indicator is **ON**

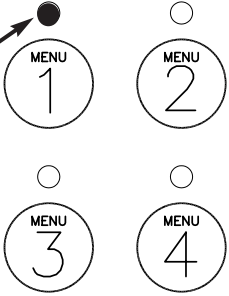

Press the active Menu Timer key



● LEFT TIMER ○ HEAT ○ RIGHT TIMER

The time is shown on the Main Display & the Left or Right indicator is **ON** to identify which Basket Timer is being displayed. Time counts down if running.

5.01.1.8 Display Actual Oil Temperature - Computer Control

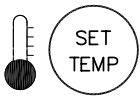

Press & Hold key for 5 seconds



Actual oil temperature will display for approx. 20 seconds

5.01.2 Electro-Mechanical Controls - Overview

The following sub-section provides instructions for operating and setting the **Electro-Mechanical Cooking Controls**.

Digital Temperature Controller (Thermostat)

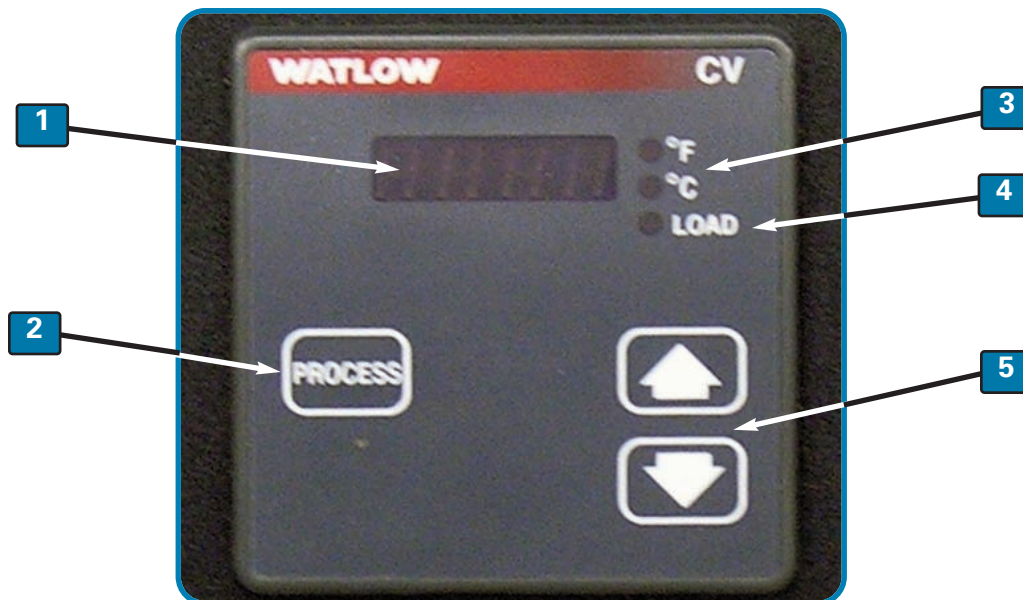

- 1 LED Display** Primarily displays temperature set-point value. Pressing and holding the **"PROCESS"** key will display actual oil temperature until released.
- 2 PROCESS Key** Press and hold to view current actual oil temperature.
- 3 °F or °C Indicator** Lit to indicate if controller is configured for degrees Fahrenheit or degrees Celsius.
- 4 LOAD Indicator Light** Lit when output to the heating elements is energized.
- 5 Up/Down Arrow Keys** Pressing these keys increment or decrement the displayed value. A new value automatically becomes effective 3 seconds after the last keystroke. These keys are inactive if the **"PROCESS"** key is being pressed and held. Releasing the key re-enables the Arrow Keys.

5.01.2.1 Setting the Temperature Unit of Measure - Mech. Control

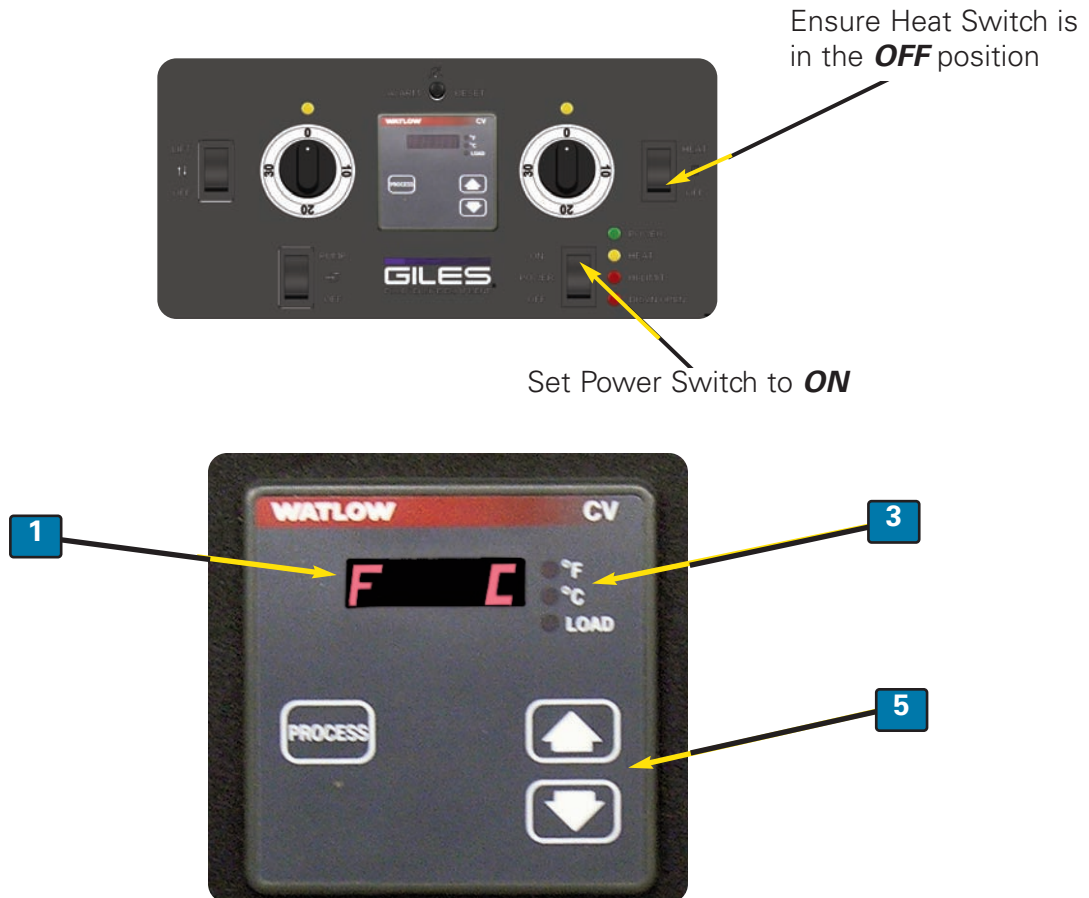

1. Set the temperature measurement unit (**F**ahrenheit or **C**elsius). Press and hold both **Arrow Keys** **5** for approximately ten (10) seconds until the LED display **1** shows [**F C**]. Within two (2) seconds, use the **Up/Down Arrow Keys** to adjust the temperature unit to the desired value. Without pressing any other keys, the new value will become effective three (3) seconds after the last keystroke. Within five (5) seconds, the LED display will blink and return to displaying the set-point value.
2. The appropriate **Temperature Unit Indicator** **3** light will illuminate to show the temperature unit for which the controller is currently configured. This setting should only be required one time.

5.01.2.2 Setting a Cooking Temperature - Mech. Control

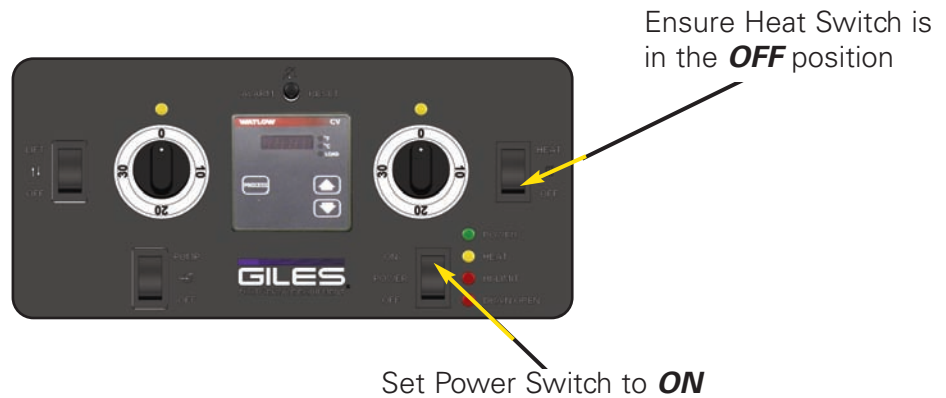

1. To set, or change, a cooking temperature set-point value, simply press the **Up/Down Arrow Keys** **5** until the desired set-point value is shown on the LED Display **1**. When the desired setting is displayed, press no other keys. The new set-point value will automatically become effective three (3) seconds after the last keystroke. **NOTE:** A set-point **cannot** be changed while the **PROCESS** **2** key is being pressed.
2. The **Temperature Unit Indicator** **3** light indicates the temperature unit for which the controller is currently configured.

5.01.2.3 Setting a Cooking Time - Mech. Control

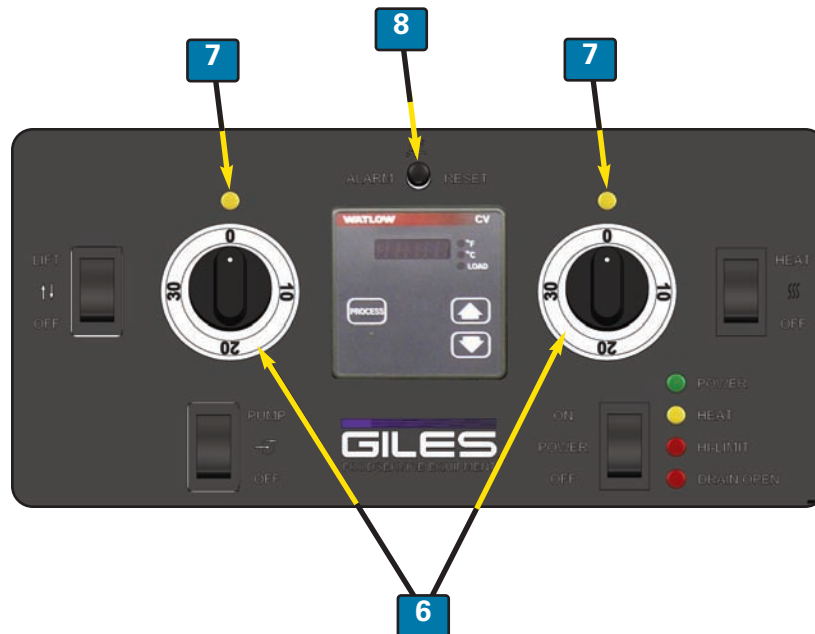

1. An Electro-mechanical Timer **6** controls cooking time for each basket. Each timer's range is **0 to 30** minutes.
2. To set a cooking time, rotate the Timer knob until the "arrow" indicator is aligned with the desired cook time. Time begins to elapse immediately when knob is released. When the cook time expires, an audible alert sounds and the indicator light **7** above the appropriate timer will turn on indicating "end of cycle" for that basket. Pressing the **ALARM RESET** Button **8** silences the alert tone.
3. To cancel a cooking cycle before it finishes, simply turn the Timer knob back to **"0"**.
4. **Basket Lift Option:** If equipped and enabled, the basket lift will lower when the Timer knob is moved off **"0"** and will automatically rise when the cook time has fully elapsed.

NOTE: *Basket Lifts installed on Fryers with mechanical controls cannot be manually operated.*

5.02 Cooking Procedure

This section describes procedures for cooking product on the GBF Series Fryer.

WARNING Except when performing the oil filtration procedure, keep the "OIL RETURN VALVE" in the lower cabinet set to the **CLOSE** position. If this valve is left in the **FILL POT** position, it is possible for oil to unintentionally siphon back into the Filter Pan, resulting in a low oil condition in the vat. This creates the potential for fire should heating elements become exposed while heating.

1. Set desired temperature set-point as described in **Sect. 5.01.1.2 (Computer Control)** or **Sect. 5.01.2.2 (Mechanical Control)**.
2. Ensure the Power Switch **1** is in the **OFF** position.
3. Ensure the Heat Switch **2** is in the **OFF** position.

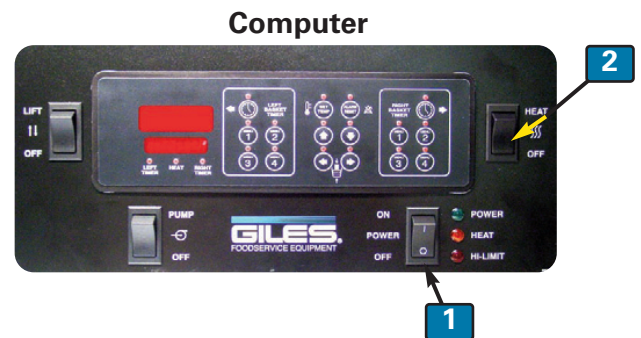

4. Ensure the Drain Valve **3** is in the **CLOSED** position (**fully to the left-hand side**).
NOTE: Fryer will not heat unless Drain Valve is fully closed.
5. Fill the fry vat with liquid shortening to the **ADD** mark **4 ONLY**. Filling only to this level allows for expansion as shortening is heated.

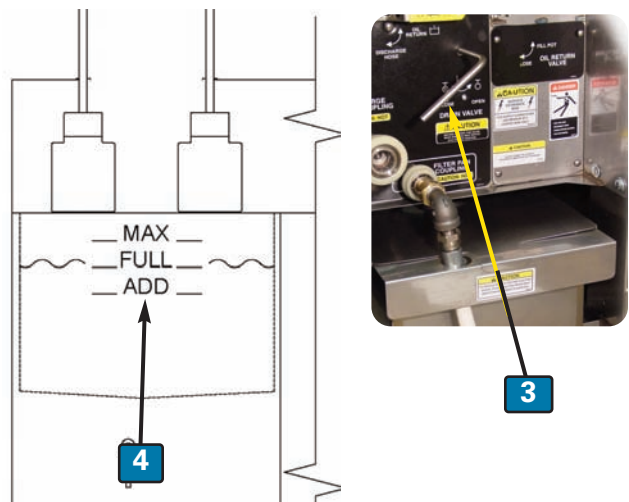

Continued next page

5.02 Cooking Procedure (continued)

6. Set the Power Switch **5** to the **ON** position. The Power Light **6** will turn on. If the unit is equipped with Basket Lifts and you wish to enable them, place the Basket Lift Switch **7** in the **LIFT** position. **If Lifts are not installed, this switch position will be plugged.**

NOTE:

- **Computer Control:** If an alarm sounds when Power Switch is placed in the **ON** position and the Scrolling Display **11** reads "*Drain Open - Close & Push Reset*", follow Step-4 above and then press the Alarm Reset key on the Controller.
- **Mechanical Control:** If an alarm sounds when Power Switch is placed in the **ON** position and the "Drain Open" indicator light **11A** is lit, follow Step-4 above and then press the **ALARM RESET** button on the Control Panel.

7. Set Heat Switch **8** to the **HEAT** position. The Heat Light **9** will illuminate.

Computer: Main Display **10** will read "**HOLD**" & the Scrolling Display **11** will read "**Oil Heating**".

Mechanical: The **Load** light **9A** on the thermostat will turn on.

Oil will begin heating to set-point temperature.

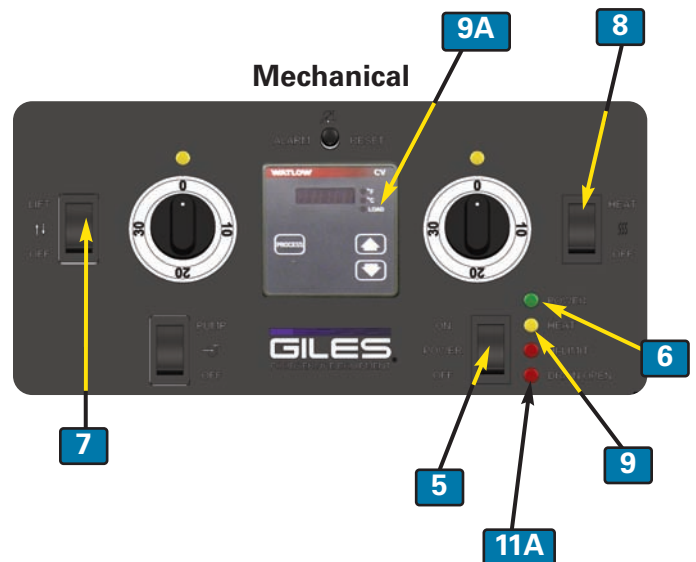
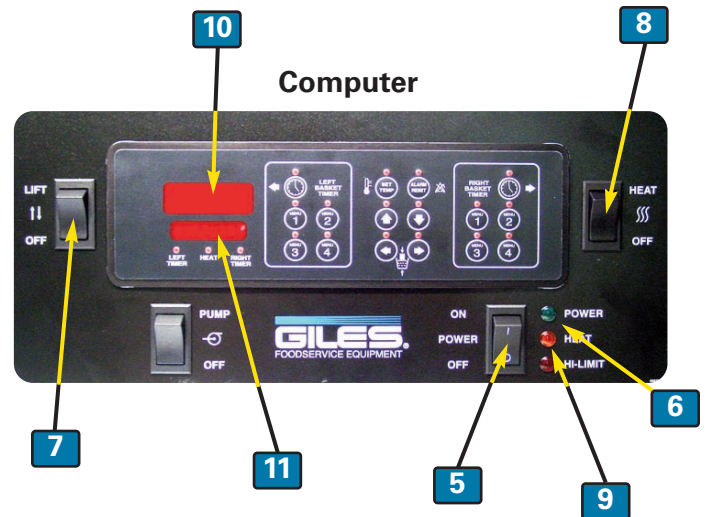

NOTE:

- During the initial heat-up of the day, particularly if cool shortening is in a thickened state, it is recommended that the vat be stirred occasionally while heating to prevent false "Hi-Limit" or "Low Oil Level" alarms.

5.02.1 Cooking Procedure - with Computer Control (continued)

- The following step will help remove any cold zones in the heated shortening, thus allowing product to cook more evenly.

CAUTION Oil is extremely HOT! Always use thermal oven mitts when stirring hot oil.

- When oil reaches a programmed pre-heat point, an alarm will sound and the Scrolling Display **11** will read “**Stir Oil & Push Reset**”. Using a suitable utensil, vigorously and thoroughly stir the heated cooking oil, then press the Alarm Reset **12** button.
- This action should mix any cool zones, providing uniform cooking temperature. When the Heat Light **13** goes out the oil has reached set-point temperature and is ready for cooking.
- Check the oil level, it should now be at the **FULL** Mark **14**. Add shortening if needed and repeat Steps 8 & 9 to ensure oil is at proper cooking temperature.
- Place the Fry Screen **15** into vat with the handles to the side.
- If Basket Lift option is installed, place the Cooking Baskets **16** onto the Basket Carriers **17**, otherwise hang baskets on Hanger Bars.

NOTE: Basket Lift Models:

If lifts are disabled, raised basket lift carriers serve as basket hangers.

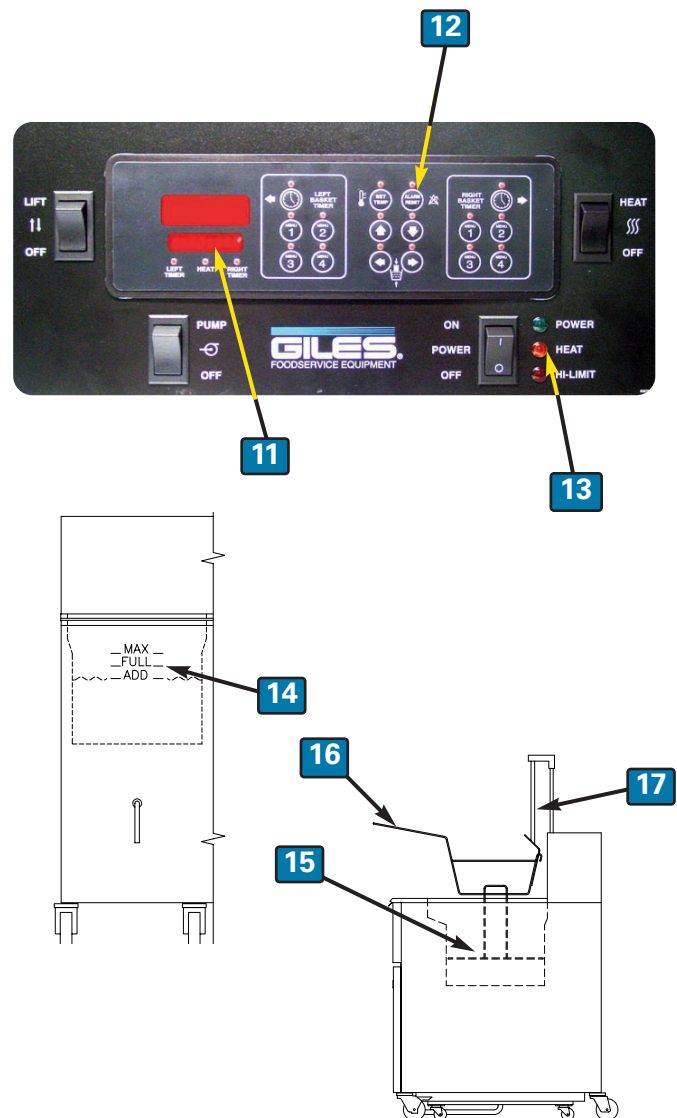

WARNING

During cooking operations, oil level **MUST** be maintained above the indicated minimum (**ADD**) level. If not maintained above that level the heating elements will shutdown.

Continued next page

5.02.1 Cooking Procedure - with Computer Control (continued)

13. It is recommended that uncooked product be placed into the Cook Basket while it is in the raised position on a Basket Lift Carrier, or hanging on the Basket Hanger bar. The basket will be automatically lowered or manually placed into the hot oil.

Uncooked product may, however, be placed into the Basket after it has been lowered or placed into the oil.



CAUTION Use extreme caution when dropping product into HOT shortening! There is potential for severe burn injury should unprotected hands contact hot oil or should an unexpected splash occur. Introducing overly wet food items or larger than recommended load sizes into the cook vat can lead to a surge boil, resulting in an overflow of HOT cooking oil from the vat. Exercise due caution when loading food and observe how the hot oil reacts before continuing.

14. **With Basket Lift:** If enabled, lifts should raise to the “up” position when the Fryer is powered-up. If needed, raise lift by pressing the desired Basket Lift select key **18** and then pressing the “Up” arrow key **19**. Place basket onto the lift carrier. The basket lift will automatically lower when a menu program is selected.

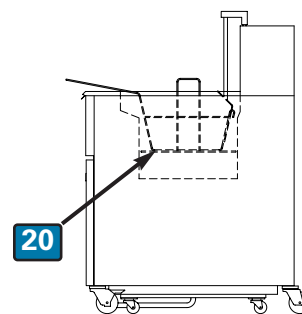

Basket Hanger, No Lift (or Lifts Disabled): Hang basket on hanger bars attached to the Fryer header (or a raised basket lift carrier).

15. **With Basket Lift:** With loaded basket on lift carrier, press desired Basket Timer Select **21** key, then press the desired Menu Item **22** key **twice**. Selected basket will lower into vat and programmed cook time begins to count down.

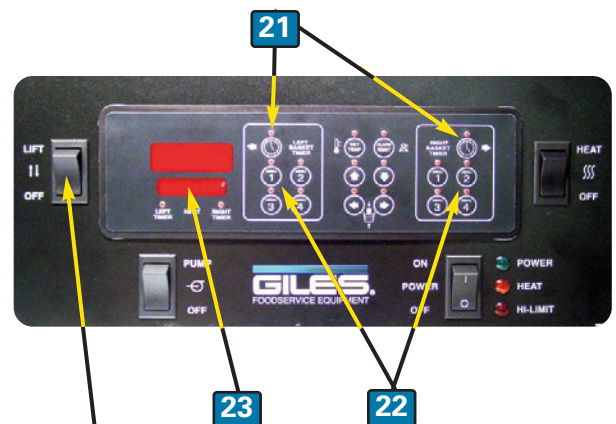

Basket Hanger, No Lift (or Lift Disabled): Load and manually place basket into fry vat, resting it on the Fry Screen **20**. Press desired Basket Timer Select **21** key, then press the desired Menu Item **22** key **twice**. Cook time begins to count down. Scrolling Display **23** will read “Cooking”.

NOTE: If Lift switch is set to **OFF**, be sure lifts are in the “up” position to serve as hangers for baskets.

Continued next page

5.02.1 Cooking Procedure - with Computer Control (continued)

16. After approx. 60% of the programmed cook time has elapsed, a **"Stir"** alarm will sound and the Scrolling Display **24** will read **"Stir Product"**. Using a suitable utensil **25** and wearing thermal oven mitts, stir the cooking product and then press the Alarm Reset key **26**. An alternative to stirring is to agitate product by shaking the cook basket. Be certain basket remains hooked onto basket lift carrier, if equipped.
17. **With Basket Lift:** When programmed cook time has expired, an alarm will sound and the Main Display **27** will read **"Done"**. The Scrolling Display **24** will indicate which timer has finished; **"Left Timer"** or **"Right Timer"** and the Cook Basket **28** will automatically be raised from the vat. Press the Alarm Reset **26** key to silence the alarm.

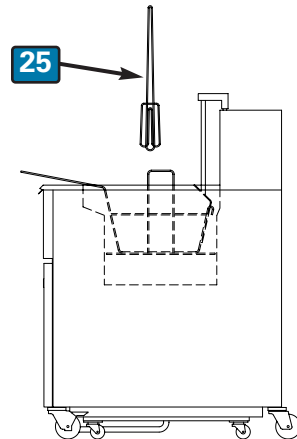

Basket Hanger, No Lift (or Lifts Disabled): When programmed cook time has expired, an alarm will sound and the Main Display **27** will read **"Done"**. The Scrolling Display **24** will indicate which timer has finished; **"Left Timer"** or **"Right Timer"**. Wearing oven mitts, lift the Cook Basket **28** from the vat and hang it on the top bar of the Basket Hanger **29**, or on the raised basket lift carrier. Press the Alarm Reset **26** key to silence the alarm.



18. Allow cooked product to adequately drain.
19. While wearing oven mitts, remove the Basket and dump cooked product into an appropriate container or dump station.
20. To continue cooking return to **Step 6** of this procedure.

To shut-down unit, see **Section 5.05, Normal Shut-Down**.

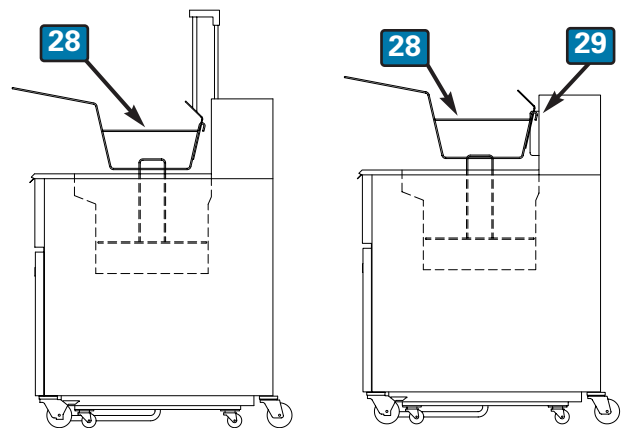

Basket Lift

Basket Hanger

5.02.2 Cooking Procedure - Mechanical Controls (continued from Page 51)

- The following step will help remove any cold areas in the heated shortening, thus allowing product to cook more evenly.

CAUTION Oil is extremely HOT! Always use thermal oven mitts when stirring hot oil.

- When the Heat Light **13** goes out, set-point is initially reached. Using a suitable utensil, vigorously and thoroughly stir the heated cooking oil until the Heat Light comes on again. This will mix any cool zones, providing uniform cooking temperature.
- When the Heat Light goes out a second time, the Fryer is ready for cooking.
- Check the oil level, it should now be at the **FULL** Mark **14**. Add shortening if needed and repeat Steps 8 & 9 to ensure oil is at proper cooking temperature.
- Place the Fry Screen **15** into fry vat with the handles to the side.
- If Basket Lift option is installed, place the Cooking Baskets **16** onto the Basket Carriers **17**, otherwise hang baskets on Hanger Bars.

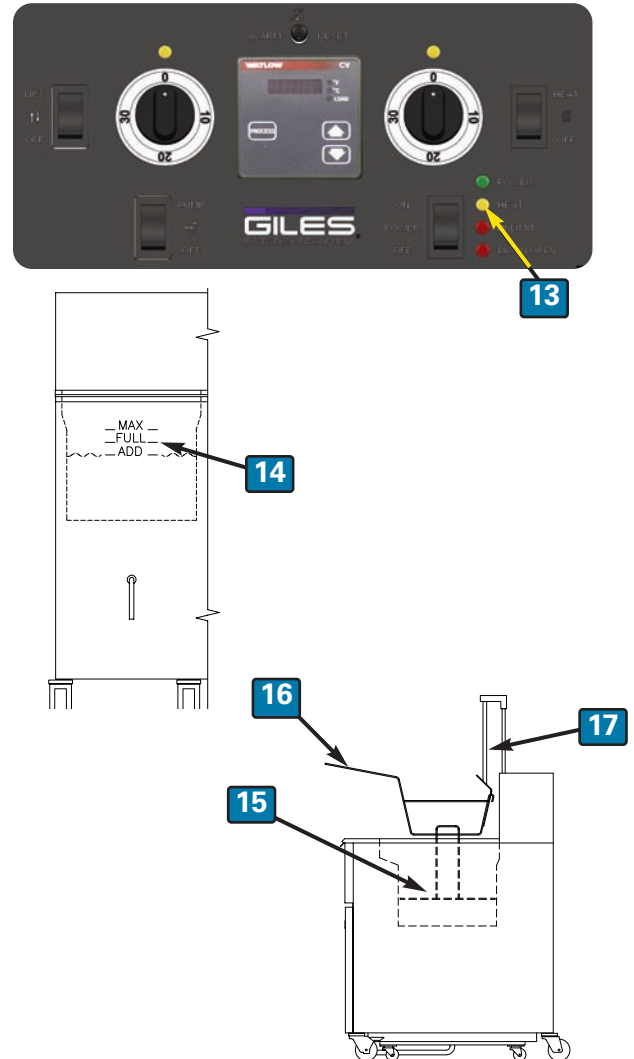

NOTE: Basket Lift Models:

If lifts are disabled, raised basket lift carriers serve as basket hangers.

WARNING

During cooking operations, oil level **MUST** be maintained above the indicated minimum (ADD) level. If not maintained above that level the heating elements will shutdown.

5.02.2 Cooking Procedure - Mechanical Control (continued)

13. It is recommended that uncooked product be placed into the Cook Basket while it is in the raised position on a Basket Lift Carrier, or hanging on the Basket Hanger bar. The basket will be automatically lowered or manually placed into the hot oil.

Uncooked product may, however, be placed into the Basket after it has been lowered or placed into the oil.



NOTE: If Lift switch is set to **OFF**, be sure lifts are in the **“up”** position to serve as hangers for baskets.

CAUTION Use extreme caution when dropping product into **HOT** shortening. There is potential for severe burn injury should unprotected hands contact hot oil or should an unexpected splash occur. Introducing overly wet food items or larger than recommended load sizes into the cook vat can lead to a surge boil, resulting in an overflow of **HOT** cooking oil from the vat. Exercise due caution when loading food and observe how the hot oil reacts before continuing.

14. **With Basket Lift:** If enabled, lifts should raise to the **“up”** position when Fryer is powered-up. Hang basket on the lift carrier. The basket lift will automatically lower when the Timer knob is moved off **“0”**.

Basket Hanger, No Lift (or Lifts Disabled): Hang basket on the hanger bars attached to the Fryer header (or on the basket lift carrier).

15. **With Basket Lift:** Place loaded basket on lift carrier. Turn the appropriate Basket Timer knob **22** clockwise until the indicator arrow aligns with the desired cook time. The corresponding basket will lower into oil. Cook time begins to elapse as soon as the timer knob is released.

Basket Hanger, No Lift (or Lift Disabled): Load and manually place basket into fry vat, resting it on the Fry Screen **20**. Set Basket Timer **22** as described above.

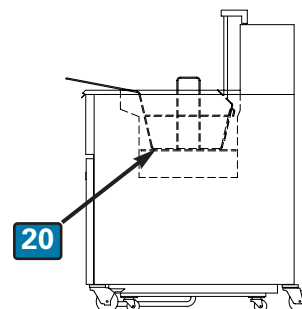

NOTE: Basket Lifts on fryers with Mechanical Controls cannot be raised or lowered manually.

5.02.2 Cooking Procedure - Mechanical Control (continued)

16. After approx. 60% of the cook time has elapsed, use a suitable utensil **25** and, while wearing thermal oven mitts, stir the cooking product. An alternative to stirring is to agitate product by shaking the cook basket. Be certain basket remains hooked onto lift carrier, if equipped.

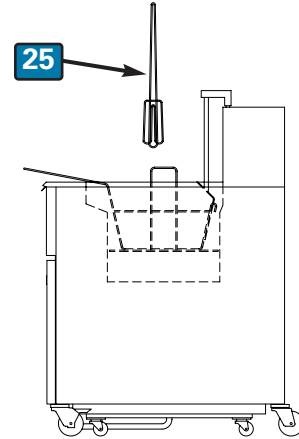

NOTE: No "Stir" alarm sounds on Mechanical Control fryers.

17. **With Basket Lift:** When the set cook time has expired, an alarm will sound and the "End of Cycle" indicator light **27** above the appropriate timer will turn **ON** to show the cycle has finished. The Cook Basket **28** will automatically be raised from the vat. Press the Alarm Reset **26** button on the Control Panel to silence the alarm.

Basket Hanger, No Lift (or Lifts Disabled): When the set cook time has expired, an alarm will sound and the "End of Cycle" indicator light **27** above the appropriate Timer will turn **ON** to show which Timer has finished. Wearing oven mitts, lift the Cook Basket **28** from the vat and hang it on the top bar of the Basket Hanger **29**, or on the raised basket lift carrier. Press the Alarm Reset **26** button on the Control Panel to silence the alarm.

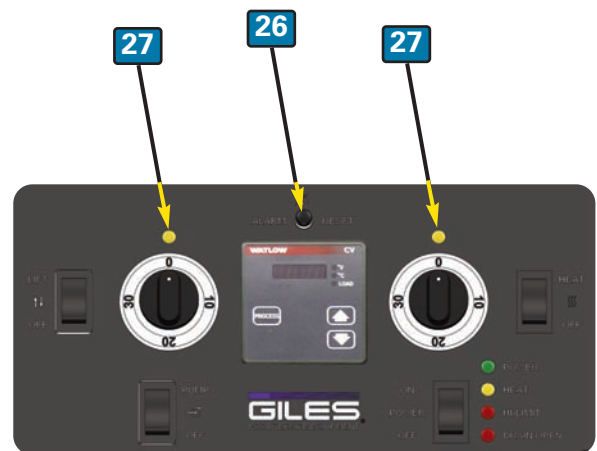

18. Allow cooked product to adequately drain.

19. While wearing oven mitts, remove the basket and dump cooked product into an appropriate container or dump station.

20. To continue cooking return to **Step 6** of this procedure.

To shut-down unit, see **Section 5.05, Normal Shut-Down.**

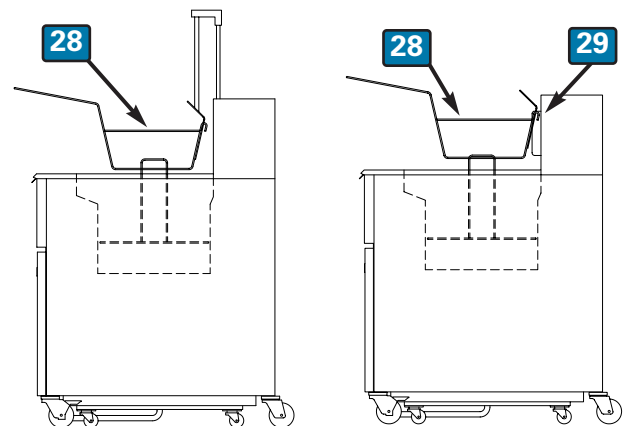

Basket Lift

Basket Hanger

5.03 Filtering Liquid Shortening

This section explains the procedure for filtering shortening with the on-board filtration system. The system recirculates used cooking oil through the Filter Pan, filter media, and back to the Cook Vat. Performing this procedure as recommended can increase shortening life up to 50%.

CAUTION

- **Never attempt to perform the filter process when shortening is cold. Doing so can clog the filter pump and damage the unit. Shortening must be heated to at least 200°F (93°C) for filtering.**

1. It is recommended that oil be filtered after every fourth (4th) load has been cooked in a Fryer.
2. Place the Heat Switch **1** of the unit requiring filtering in the **OFF** position.
3. Open Cabinet Door (**door of cabinet w/filter pan on a "banked" battery**). While wearing oven mitts, disconnect the Filter Pan hose **2** by pushing the white slip-ring "in" while pulling the hose from connector. Remove Filter Pan **3** from unit.
4. Ensure that filter media is in place. Media will either be the standard reusable Stainless Mesh Screen (SSFS) or one (1) sheet of disposable Filter Paper. Check that Hold-down Frame is properly locked down.
5. Add approximately 4-3/4 oz. of a suitable Filter Powder (**available from Giles, P/N 72004**), distributing evenly over the filter media surface.
6. Replace Cover **4** on Filter Pan, reposition Pan under unit and reconnect Filter Pan hose **2** (push slip-ring "in" while inserting brass hose fitting in connector). Ensure tight fit.

NOTE: The Computer Control is depicted in this section. There is no difference in the process for fryers with Mechanical Controls.

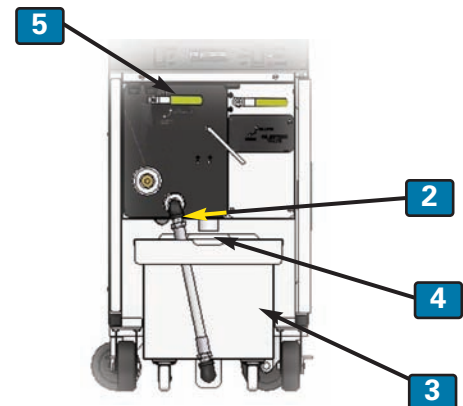

DANGER

- **During the next step hot shortening is drained from the vat, thus exposing the Heating Elements. Even though safety interlocks are in place, failure to have fryer's Heat Switch in the OFF position before draining may result in a flash fire. ALWAYS CONFIRM THE HEAT SWITCH IS IN THE "OFF" POSITION BEFORE DRAINING THE COOK VAT.**

WARNING

- **For "banked" fryer batteries: Never drain more than one (1) vat at a time into the Filter Pan! The pan only has capacity to hold oil from one (1) cook vat.**
- **Never disconnect and attempt to remove the Filter Pan from unit while it contains liquid shortening.**

Continued next page

5.03 Filtering Liquid Shortening (continued)

- Confirm that Heat Switch **1** remains in the **OFF** position. On the lower cabinet panel (**cabinet w/filter pan on a "banked" battery**), ensure the Pump Diverter Valve **5** is in the **"OIL RETURN"** position (horizontal). On unit being filtered, slowly move Drain Valve Handle **6** to the **OPEN** (right-most) position. The cooking oil should begin draining into the Filter Pan.

NOTE:

- If the oil does not readily drain, use the provided Kettle Drain Brush to break up crumbs or residue that might be blocking the vat drain.

CAUTION

- Be careful not to puncture the filter media in Pan. This could allow debris to pass through and clog or damage the filter pump.

- On the unit being filtered, set the Oil Return Valve handle **7** to the **"FILL POT"** position (horizontal). **On a "banked" fryer battery, Oil Return Valves of all other vats must be in the CLOSE position (vertical).**

- When oil has completely drained into the Filter Pan, set the Pump Switch **8** to the **PUMP** position. **On a "banked" fryer battery, switch is located on the Control Panel of unit with the Filter Pan (all other units have this switch location plugged).**

- The used oil will begin to circulate **9** through the filter media in the Pan and return to the fry vat. Leave the Drain Valve open to allow oil to continually recirculate through the system for approx. 5 minutes. During this time, use the teflon Pot Brush and L-Bend Brush to dislodge cooking residue and crumbs from the vat sides and elements, allowing it to be flushed into the Filter Pan.

- After approx. 5 minutes, return Drain Valve Handle **10** to the **CLOSE** position and allow the vat to refill. When the pump discharge begins "blowing" air, refilling is complete.

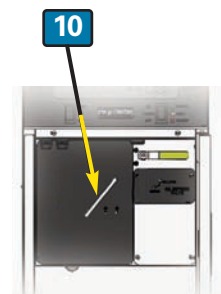
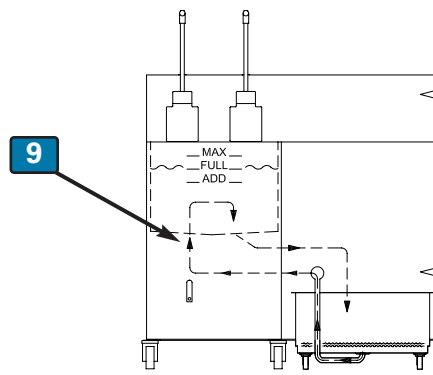
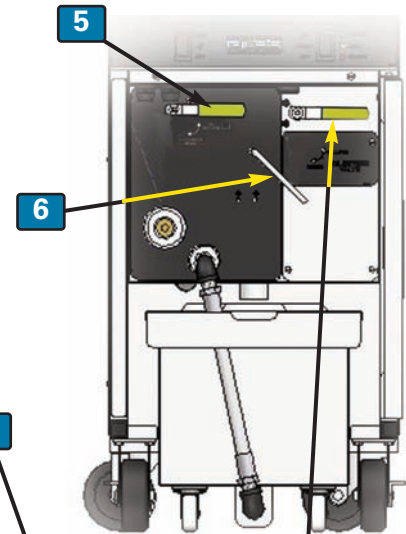

Continued next page

5.03 Filtering Liquid Shortening (continued)

12. After the fry vat has refilled, return Pump Switch

11 to the **OFF** position.

13. Turn the Oil Return Valve handle **12** of the unit being filtered to the **CLOSE** position.

WARNING

- **Oil Return Valve must remain in the *CLOSE* position except when filtering. Failure to do so can allow oil to unintentionally siphon back to the Filter Pan, causing a low oil condition in the vat.**

14. Confirm that the fry vat has maintained the proper shortening fill level ... add if needed.

CAUTION

- **Always wear thermal oven mitts when performing this step. Parts can be excessively hot!**

15. After refilling vat, remove Filter Pan from fryer (**see Step-3**). Use the supplied Crumb Shovel **13** and taking care not damage or puncture the filter media, scoop filter sediment from its surface and dispose. It is not essential that filter media be refreshed after each filter cycle, but it is recommended to clean the Filter Pan and refresh media at least every day (**see steps for refreshing filter media in Sect. 6.03**).

16. Reinstall Filter Pan under unit.

17. To continue cooking, see **Section 5.02, Cooking Procedure**.

To discontinue cooking, see **Section 5.05, Normal Shut-Down**.

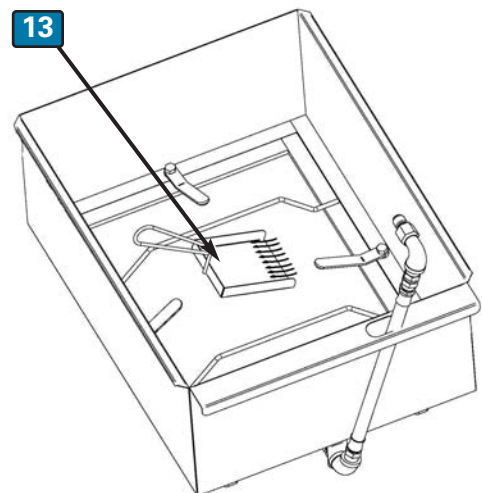
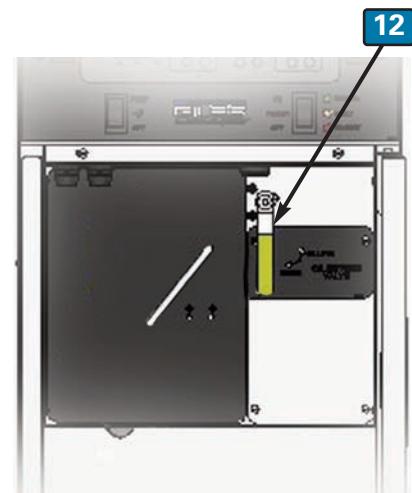

5.04 Removal of Used Shortening from Fryer

This section explains the procedure for removing used shortening from the unit for disposal. Oil must be removed before a Boil-Out procedure can be performed. In this section a Giles Oil Caddy (**not included**) is depicted for oil disposal; any suitable container can be used.

CAUTION

- **Never attempt to pump cold shortening. Doing so can clog the filter pump and damage the unit. Shortening must be heated to at least 200°F (93°C) before attempting to pump.**

1. If used shortening is cold, heat to at least **200°F (93°C)**.
2. Confirm that Power Switch **1** is in the **ON** position, and the Heat Switch **2** is in the **OFF** position. **On a “banked” fryer battery**, Power Switch of the unit with Filter Pan also must be **ON**.
3. **For “banked” fryer batteries this step refers to the unit with Filter Pan.** Ensure the Filter Pan **3** and Filter Pan Cover **4** are in place. Confirm the Filter Pan hose **5** is properly and tightly connected at the quick-disconnect. Verify the Pump Discharge Handle **6** is in the **OIL RETURN** position.

NOTE: The Computer Control is depicted in this section. There is no difference in the process for fryers with Mechanical Controls.

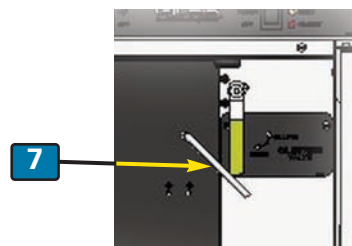
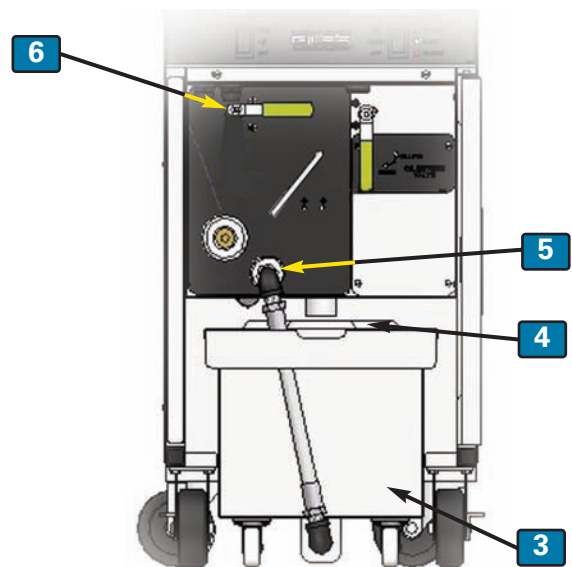

DANGER

- **During the next step hot shortening is drained from the vat, thus exposing the Heating Elements. Even though safety interlocks are in place, failure to have fryer’s Heat Switch in the OFF position before draining may result in a flash fire. ALWAYS CONFIRM THE HEAT SWITCH IS IN THE “OFF” POSITION BEFORE DRAINING THE COOK VAT.**

WARNING

- **On “banked” fryer batteries, never drain more than one (1) vat at a time into the Filter Pan! The Pan only has capacity to hold oil from one (1) cook vat.**
- **Never disconnect and attempt to remove the Filter Pan from unit while it contains liquid shortening.**

4. Slowly position Drain Valve Handle **7** to the **OPEN** position and allow oil to completely drain into the Filter Pan.

Continued next page

5.04 Removal of Used Liquid Shortening (continued)

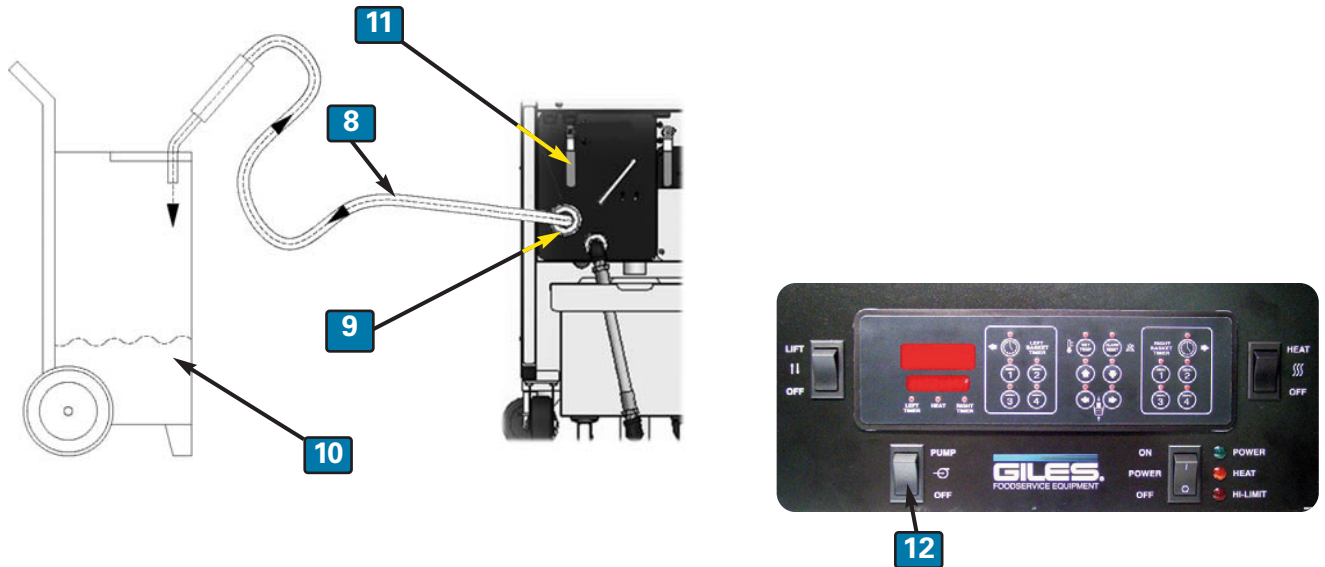

For “banked” fryer batteries, this instruction refers to the unit with Filter Pan :

5. Connect the Oil Discharge Hose **8** to the Discharge Coupling **9** by pushing slip-ring “in” while inserting brass hose fitting. Ensure that connection is secure.
6. Place the discharge end of hose into an appropriate hot oil disposal container **10** (Giles Oil Caddy is depicted)
7. Set the Pump Diverter Valve **11** to the “**DISCHARGE HOSE**” position.

WARNING

- If holding the Discharge Hose during the next step, be sure the wear thermal oven mitts. Some parts of the hose assembly can become very hot.

8. Set the Pump Switch **12** to the **PUMP** position and allow used shortening to be pumped into the disposal container. When all oil has been pumped out of the filter pan, return the Pump Switch to **OFF**.

5.04 Removal of Liquid Shortening (continued)

9. Set Power Switch **13** to the **OFF** position.
10. **On the unit being drained**, position Drain Valve Handle **14** to the **CLOSE** position.
11. Place the Pump Diverter Valve handle **16** to the **"OIL RETURN"** position.

WARNING

- During the next step be sure the wear oven mitts. Some parts of the Discharge Hose assembly and coupling will become very hot.

12. Remove the Discharge Hose from the Discharge Hose Coupling by pushing the slip-ring "in" while pulling the hose fitting out. Drain any oil remaining in the hose into the oil disposal container.
13. Allow the Filter Pan to sufficiently cool. Remove the Filter Pan assembly, disassemble and thoroughly clean.
14. To perform a Boil-Out on the unit, see **Section 6.01, Boil-Out Procedure**.

To shut down unit, see **Section 5.05, Normal Shut-Down**.

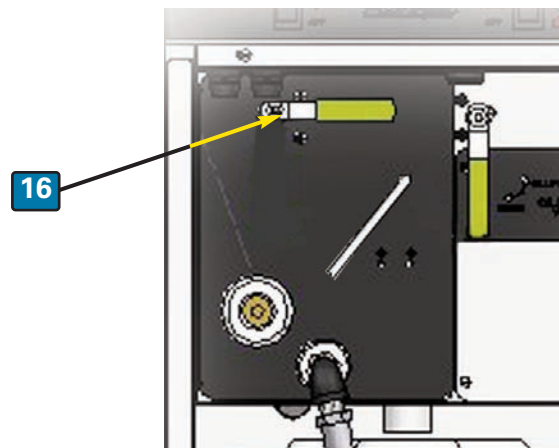
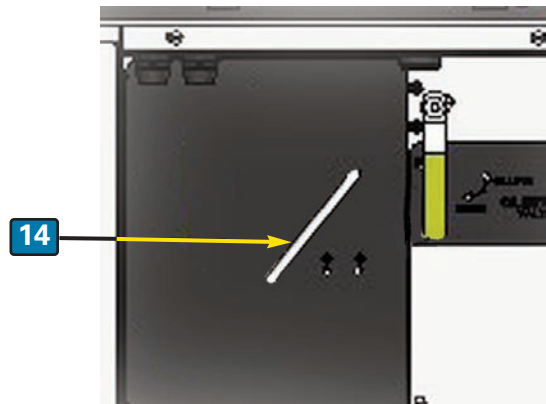

5.05 Normal Shut-Down

This section explains the process of shutting down the Fryer(s). For “banked” fryer batteries, this must be done for each unit in the bank.

1. Set Heat Switch **1** to **OFF** position.
2. Place Power Switch **2** in the **OFF** position, the Power Light **3** will turn off.
3. If required by local standard operating procedures, turn off supply power at the main circuit breaker panel or disconnect box.
4. Verify that the Oil Return Valve **4** is set to the **CLOSE** position. Failure to do this can allow oil to be siphoned back to the Filter Pan.

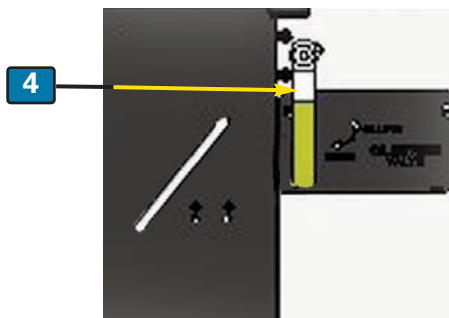

5.06 Emergency Shut-Down

In case of emergency, remove supply power to the unit(s) by switching off main circuit breaker or disconnects within the building.

6. Cleaning

This section describes cleaning procedures for GBF Series Fryers. Giles recommends that general cleaning and Filter Pan cleaning be performed on a daily basis, at a minimum.

DANGER

- **DO NOT** wash down the unit's interior or exterior with water from a spray hose or any pressure-type washer.
- **Failure to comply with DANGER notices will result in death or serious injury, equipment or property damage, and void the warranty.**

6.01 Boil-Out Procedure (Cleaning the Fry Vat)

This section explains how to clean the fry vat using the Boil-Out procedure. A Boil-Out procedure must be performed before cooking in new equipment and should be performed each time shortening is changed in the fryer.

For proper fryer maintenance and operation, the Boil-Out Procedure should be performed every 7 to 14 days, at a minimum.

DANGER

- **DO NOT, under any circumstances, leave the fryer unattended during this procedure as it may become necessary to adjust the heat setting to prevent vat overflow. An overflow can result in serious equipment damage.**

1. Remove shortening from the unit, see **Sect. 5.04, Removal of Liquid Shortening**.
2. Ensure the Drain Valve Handle **1** of the unit to be cleaned, is in the **CLOSE** position and the Power Switch **3** is in the **OFF** position.
3. Fill the fry vat to the **FULL** level mark **2** with fresh water.
4. Use a suitable Boil-Out/Vat Cleaning product and follow the manufacturer's usage instructions. Add the recommended amount of product to water in the vat and stir to mix.

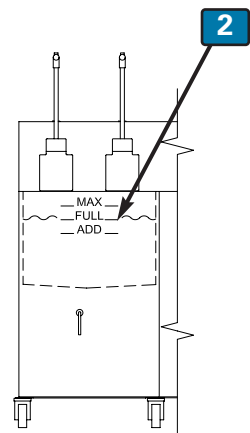
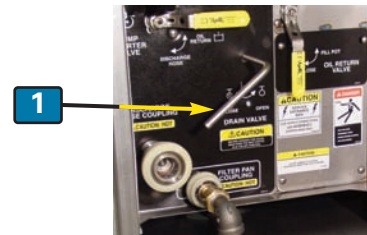

CAUTION

- **Closely follow to the cleaning product manufacturer's usage instructions. Many commercially available cleaners contain caustic chemicals and require special precautions when used. Improper use could damage the fryer and potentially cause personal injury.**

Continued next page

6.01 Boil Out Procedure (continued)

5. Place the Power Switch **3** in the **ON** position.
6. Set the temperature set-point to that recommended for the boil-out product, typically **200 °F (93 °C)**. See **Sect. 5.01.1.2 (Comp. Control)** or **Sect. 5.01.2.2 (Mech. Control)**.
7. Place the Heat Switch **4** in the **HEAT** position.
8. See the cleaning product's instructions for suggested cleaning cycle time. If desired, set one of the basket timers to the suggested time. See **Sect. 5.01.1.3 (Comp. Control)** or **Sect. 5.01.2.3 (Mech. Control)**.
9. At the completion of the Boil-Out cycle time, place the Heat Switch **4** and Power Switch **3** in the **OFF** position.

NOTE: The Computer Control is depicted in this section, however there is no difference in the process for fryers with Mechanical Controls.



CAUTION

- A "rolling boil" is not necessary to achieve desired cleaning action. Follow directions for the product being used.

A "rolling boil" could result in overflow and cause damage to the unit.

10. Disconnect Filter Pan hose and remove the Filter Pan from the unit or "banked" fryer battery.
11. Position a suitable **heat resistant container** **5** (not supplied with Fryer) beneath the fryer drain. **NOTE:** "Banked" fryer batteries feature multiple Drain Tubes; be certain container is positioned so that used boil-out solution will properly drain into it.
12. Slowly move the Drain Valve Handle **6**, on the fryer containing boil-out solution, to the **OPEN** position.

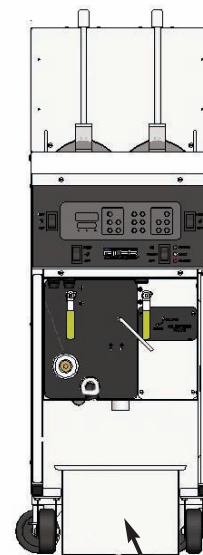

5 NOT THE FILTER PAN

WARNING

- **NEVER** drain boil-out solution into the Filter Pan or run it through the filter system using the Filter Pump. Solution is caustic and will damage the pump and other components. Doing this will void the warranty!

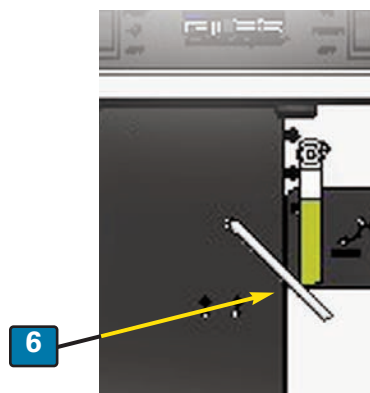

Continued next page

6.01 Boil Out Procedure (continued)

13. As needed, scrub vat sides, bottom, and heating elements with the provided teflon Pot Brush and L-Bend Brush to remove residue. Rinse and flush the vat thoroughly with warm tap water. **Note: Take care not to damage the temperature probes that protrude from the front wall of the fry vat (see below).**
14. Completely dry the vat and elements with a clean dry towel, and properly dispose of the used boil-out solution.
15. Return Drain Valve Handle **6** to the **CLOSE** position.
16. Clean the Filter Pan and replace filter media, **see Sect. 6.02, Cleaning the Filter Pan & Refreshing Filter Media.**
17. Replace Cover **7** and position Filter Pan **8** under unit. Connect Filter Pan hose **9** to the quick-disconnect coupling (push slip-ring "in" while inserting hose fitting); connection must be tight and secure.
18. Restart the fryer for cooking activities, **see Sect. 5.02.**

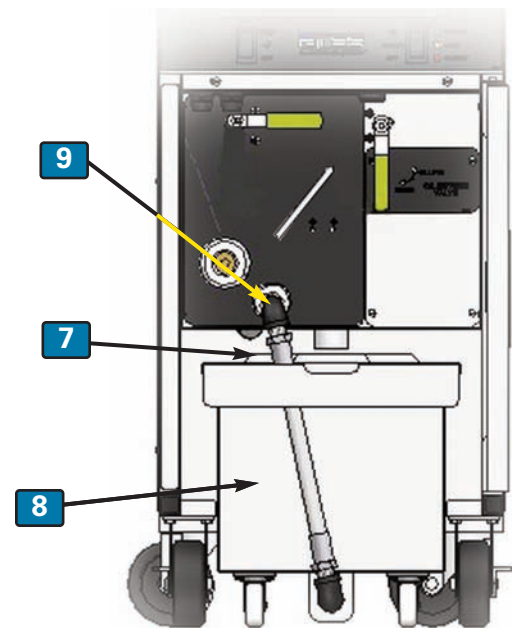
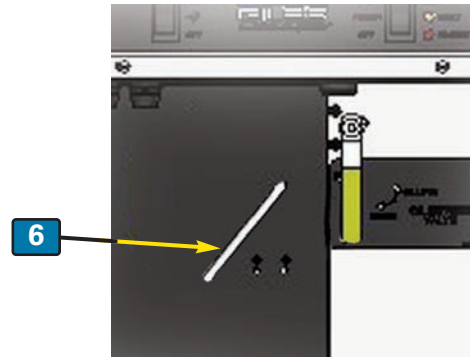

Temp. Probes

6.02 Cleaning the Filter Pan & Refreshing Filter Media

This section explains the procedure for cleaning the Filter Pan and refreshing the filter media - either the standard reusable steel mesh screen (SSFS) or disposable filter paper. At a minimum, this should be done once per day of operation, and each time a Boil-Out procedure (**Sect. 6-01**) is performed.

CAUTION

• Use thermal oven mitts to protect hands from potentially hot parts, as needed.

1. Remove Filter Pan from fryer if necessary.
2. Remove and clean the Filter Pan Cover **1** using a bio-degradable, non-toxic, degreaser - dry thoroughly.
3. Use the provided metal Crumb Shovel to remove the major portion of filter sediment accumulated on the filter media surface, particularly around the edge of the Hold-down Frame. This will help prevent sediment from falling into the pan bottom through the perforated filter media Support Screen **5**, which could potentially lead to a clogged filter pump.
4. Turn the four levers **2** (attached to the frame in Pan bottom) to disengage the Hold-down Frame **3**. Remove frame, clean and dry thoroughly.
5. Grasp one end of the filter media **4** and carefully remove from Pan. Avoid letting filter sediment fall through the perforated Support Screen **5** in the Pan bottom.
6. Thoroughly clean and dry the Filter Pan **6**. Flush out any filter sediment that may have fallen through the perforated screen and be certain to drain any residual water from Filter Pan hoses.

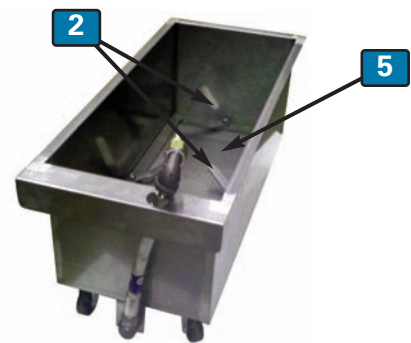
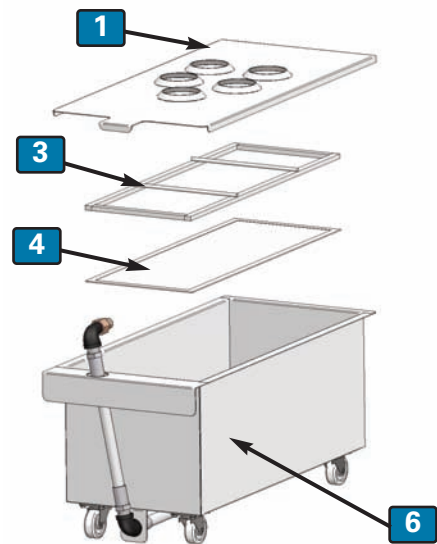

NOTE:

The perforated, Support Screen **5** in the bottom of the Filter Pan is **NOT** a filter. Proper filter media (reusable mesh screen or filter paper) must be used to avoid possible equipment damage. Failure to use proper filter media will void the warranty!

6.02 Cleaning the Filter Pan & Refreshing Filter Media - continued

7. Reassemble Filter Pan with new or refreshed filter media (cleaned Filter Screen or new sheet of filter paper). Be certain that the filter media is properly placed underneath the Hold-down Frame and that the frame is locked securely in place by the (4) levers.

Filter Media Note:

- A reusable Stainless Steel Filter Screen (SSFS) is standard on GBF Series Fryers - wash soiled screen in sink, using a stiff bristle brush, with clean hot water **ONLY**; **DO NOT** use soap. Shake off excess water and blot dry with clean towel (ideally screen should dry overnight). Reinstall in pan.
- Filter Paper - remove soiled paper and discard. Replace with one (1) fresh sheet of proper sized filter paper.
Available from Giles: P/N 65871.

8. Replace Pan Cover **7**, position assembled Filter Pan under the unit and re-connect filter pan hose **8** to the quick-disconnect coupling (push slip-ring "in" while inserting hose fitting). The connection must be tight and secure for proper operation.

NOTE: Stainless Steel Filter Screen (SSFS)

With proper use and care, this reusable filter screen should have a long service life. However, it should be replaced if it becomes torn, punctured, frayed or if the silicone sealing gasket around the edge becomes significantly damaged.

Proper use of a suitable filter powder is essential to the performance of this filter.

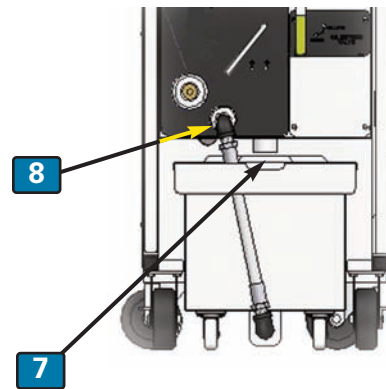

7. Troubleshooting

This section describes various troubleshooting procedures. If needed, refer to the wiring diagram included with this manual or affixed to the Fryer(s) Back Panel(s) as an aid for more detailed analysis.

7.01 Temperature Control System		
Problem	Probable Cause	Repair Procedure
FRYER WILL NOT TURN ON: No power light	A. Not connected to power source	A. Connect to power source
	B. Faulty fuse or circuit breaker	B. Check fuse or breaker
	C. Fuse holder cracked	C. Replace fuse holder
	D. Faulty Power Switch	D. Replace Power Switch
	E. Improper supply voltage	E. Connect to proper voltage source
FRYER WILL NOT HEAT: Power light ON . Heat light OFF .	A. Heat Switch not in " HEAT " position.	A. Place Heat Switch in " HEAT " position.
FRYER WILL NOT HEAT: Power light ON . Heat Switch in " HEAT " position. Heat light OFF .	A. Temp. set-point is below actual oil temperature.	A. Set controller or thermostat to desired cooking temperature.
	B. Drain Valve open or not fully closed.	B. Fully close Drain Valve. Press Alarm Reset Button.
	C. Faulty Controller or Digital Thermostat	C. Replace Controller or Digital Thermostat.
	D. Faulty variable probe.	D. Replace probe.
	E. Loose wiring.	E. Repair wiring.
	F. Faulty contactor.	F. Replace faulty contactor.
	G. Faulty element.	G. Replace element.
	H. Faulty Heat Switch.	H. Replace Heat Switch.
	I. Low Oil Level (alarm sounding) Computer ONLY	I. Turn Power Switch OFF , add oil to proper level & restart.

7.01 Temperature Control System (continued)		
Problem	Probable Cause	Repair Procedure
FRYER HEATING SLOW or SLOW RECOVERY TIME Heat light stays ON , does not cycle on & off.	A. Incorrect cooking procedures.	A. Consult Operations Manual for proper procedure.
	B. Element beginning to fail.	B. Replace faulty element.
	C. Contactor beginning to fail.	C. Replace faulty contactor.
	D. Loose wiring.	D. Repair wiring.
	E. Low supply voltage.	E. Confirm proper supply voltage.
FRYER HEATS SLOW; Short Cycling Heat light OFF & ON CONTINUOUSLY .	A. Low supply Voltage.	A. Confirm proper supply voltage.
	B. Variable probe touching element.	B. Reposition variable probe.
	C. Faulty Controller or Digital Thermostat.	C. Replace Controller or Digital Thermostat.
OIL TEMPERATURE ERRATIC:	A. Faulty probe.	A. Replace probe.
	B. Contactor beginning to fail.	B. Replace contactor.
	C. Faulty Controller or Digital Thermostat.	C. Replace Controller or Digital Thermostat.
	D. Loose wiring.	D. Repair loose wiring.
OIL SMOKING:	A. Old cooking oil, used too long.	A. Change cooking oil.
	B. Temperature too high.	B. Check temperature setting.
	C. Dirty element.	C. Clean elements, use L-Bend Brush.
	D. Faulty element.	D. Replace element.
	E. Improper element voltage.	E. Provide proper voltage.
	F. Low oil level.	F. Keep oil at FULL Level.

7.01 Temperature Control System (continued)		
Problem	Probable Cause	Repair Procedure
FRYER WILL NOT HEAT: Power light ON . Heat Switch in HEAT position. High Limit light ON .	A. Power surge.	A. Turn Power Switch OFF for approx. 5 seconds.
	B. Sticking contactor.	B. Replace contactor.
	C. Faulty High-Limit board.	C. Replace High-Limit board.
	D. Faulty High-Limit probe.	D. Replace High-Limit probe.
	E. Line spikes or noise.	E. Install Line Filter or remove noise source.

7.02 Oil Filtration System		
Problem	Probable Cause	Repair Procedure
OIL NOT RETURNING TO FRY VAT	A. Pump Switch not in PUMP position.	A. Set Pump Switch to PUMP position.
	B. Air leaks (hoses, fittings, filter media).	B. Repair source of air leak.
	C. Faulty pump motor.	C. Replace pump motor.
	D. Oil pump clogged or jammed.	D. Free pump, clear obstruction.
	E. Pump Diverter Valve not set to OIL RETURN position	E. Place Pump Diverter Valve in OIL RETURN position
	F. Oil Return Valve set in CLOSE position	F. Place Oil Return Valve in FILL VAT position
	G. Pump had been used to pump boil-out solution.	G. Disassemble, clean & re-oil pump.
	H. Old oil allowed to sit in pump too long.	H. Run clean warm oil through pump.
	I. Oil too cool in Filter Pan.	I. Remove Filter Pan & manually remove cool or cold oil.
	J. Filter Pan assembled incorrectly.	J. Assemble Filter Pan correctly.
	K. Dirty Filter Pan.	K. Clean Filter Pan.



7-03. Basket Elevator System (Basket Lift Option Only)		
Problem	Probable Cause	Repair Procedure
BASKET WILL NOT GO UP OR DOWN (Applies Only to Fryers with Basket Lift Option)	A. Power not ON .	A. Set Power Switch to ON position.
	B. Faulty Controller or Timer.	B. Replace Controller or Timer.
	C. Basket Lift micro-switch out of adjustment.	C. Adjust micro-switch.
	D. Faulty Lift micro-switch.	D. Replace micro-switch.
	E. Basket Lifts disabled.	E. Place Lift Switch to LIFT position.
	F. Faulty lift motor.	F. Replace motor.
	G. Faulty relay (Mech. Timer ONLY)	G. Replace relay



NOTES:

8. Parts List

This section lists some of the various parts that are available for replacement on the unit. This is not an all inclusive listing; please contact an authorized Giles representative or service agent concerning other parts that may be replaced in the field.

8.01 Parts Ordering and Service Information

If you require assistance or need repairs, please contact a Giles Representative for assistance in locating a service agent in your area. For further assistance, please contact Giles Enterprises, Inc. at one of the following phone numbers:

IN THE UNITED STATES, CANADA or MEXICO

Call **800.554.4537** during normal business hours, 8:00AM to 5:00PM Central Time. For emergency equipment repair service after normal business hours, call 800.554.4537 and follow the recorded prompts to reach after-hours support..

IN ALL OTHER COUNTRIES

Call **334.272.1457** during normal business hours, 8:00AM to 5:00PM Central Time Zone and follow the recorded prompts. For emergency equipment repair service after normal business hours call, 334-272-1457 and follow the recorded prompts to reach after-hours support..

WEBSITE: www.gfse.com **E-mail:** services@gfse.com

The goal at Giles is to provide the best service and customer support in the industry. To help us accomplish this, please become familiar with the equipment specification data and refer to it when calling. The information is located on a Data/Serial Label attached to the Back Panel of each Fryer unit.

MODEL/MODELE		SERIAL NO/NO. DE SERIE		
VAC/VCA	HZ	PHASE	AMPS	WATTS
DESCRIPTION/DESCRIPCIÓN				
GILES ENTERPRISES				
1-800-554-4537				
2750 GUNTER PARK DRIVE WEST • MONTGOMERY • ALABAMA • 36109				

An area is provided inside this Manual's front cover for recording this information as a quick and easy reference.

8.02 Control Panel (Computer & Mechanical): Single Unit & Main Unit for a "Banked" Battery

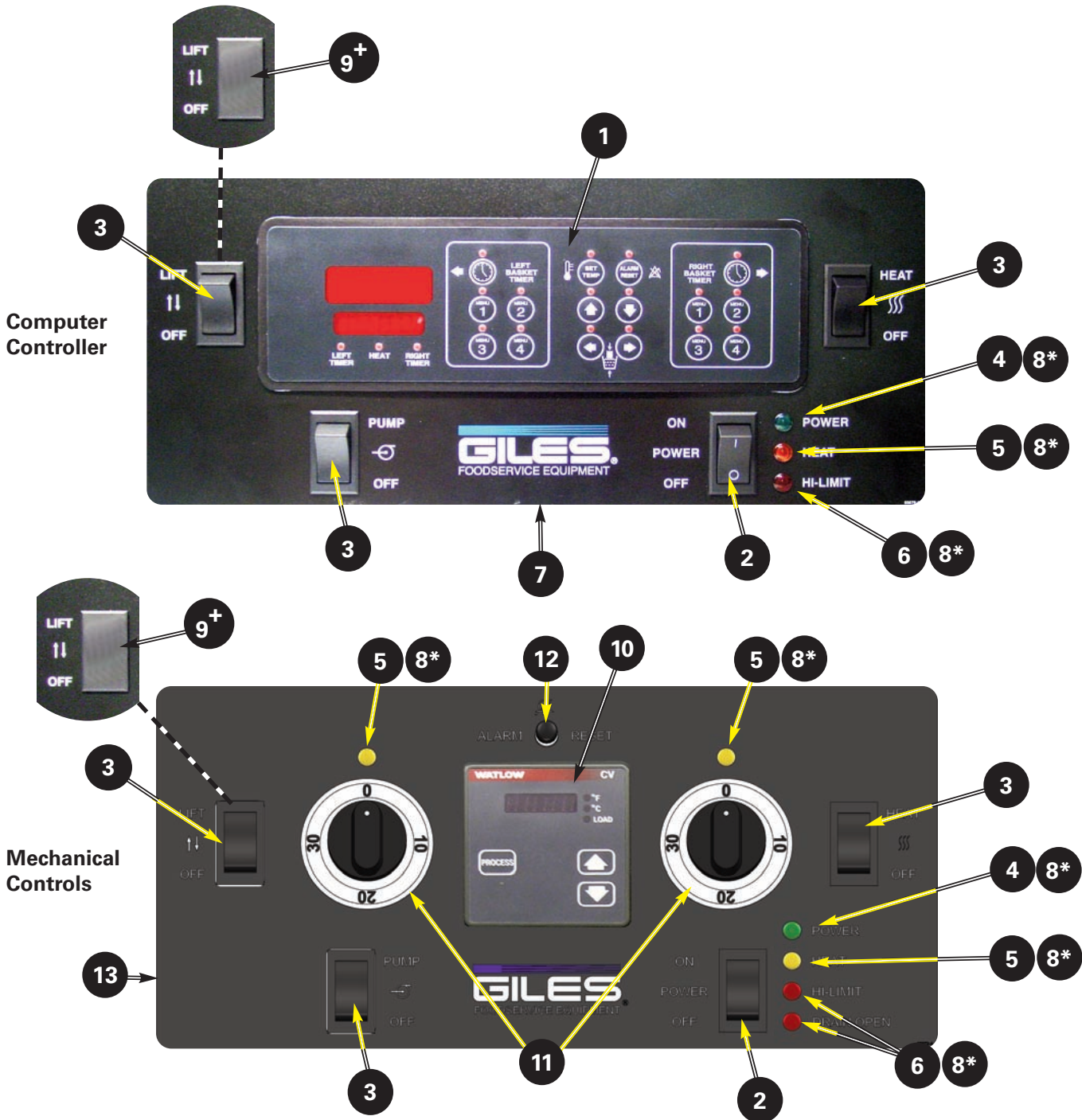

* Not Shown
 † Switch location is plugged on Units without Basket Lift Option



8.02 Control Panel (Computer & Mechanical): Single Unit & Main Unit for a "Banked" Battery

ITEM	PART NO.	QTY	DESCRIPTION
1	20326	1	CONTROLLER, N7, WATLOW
2	21190	1	SWITCH, ROCKER, ON-OFF, 250V, 20A, DPST
3	21052	3 or 2	SWITCH, ROCKER ,ON-OFF-ON, 250V, 20A, DPDT
4	20398	1	INDICATOR LIGHT, GREEN, 250VAC
5	20399	1 or 3	INDICATOR LIGHT, ORANGE, 250VAC
6	20402	1 or 2	INDICATOR LIGHT, RED, 250VAC
7	65676	1	LABEL, CONTROL PANEL, GBF
8*	20307	3 or 6	RETAINING CLIP, INDICATOR LIGHT
9†	20621	1	PLUG, SWITCH CUT-OUT (For Units <u>WITHOUT</u> Basket Lift Option)
10	20484	1	CONTROLLER, TEMPERATURE, WATLOW CV, 0-375°F
11	24240	2	TIMER, 30-MIN, MECHANICAL, DIEHL
12	20109	1	SWITCH, PUSH-BUTTON, 250V, 10A, N.C.
13	65872	1	LABEL, CONTROL PANEL, GBF, MECHANICAL TIMERS

* Not Shown

† Used on Units without Basket Lift Option

8.03 Control Panel (Computer & Mechanical): Add-On Units for "Banked" Battery

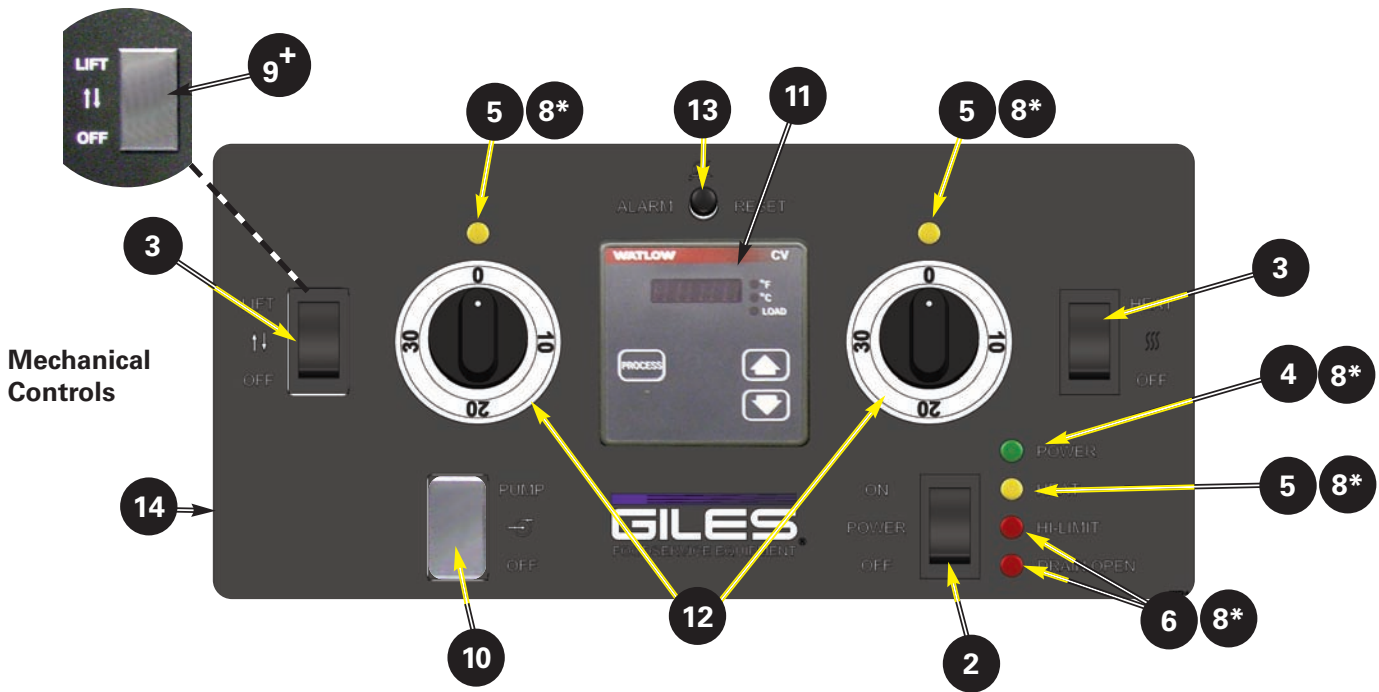
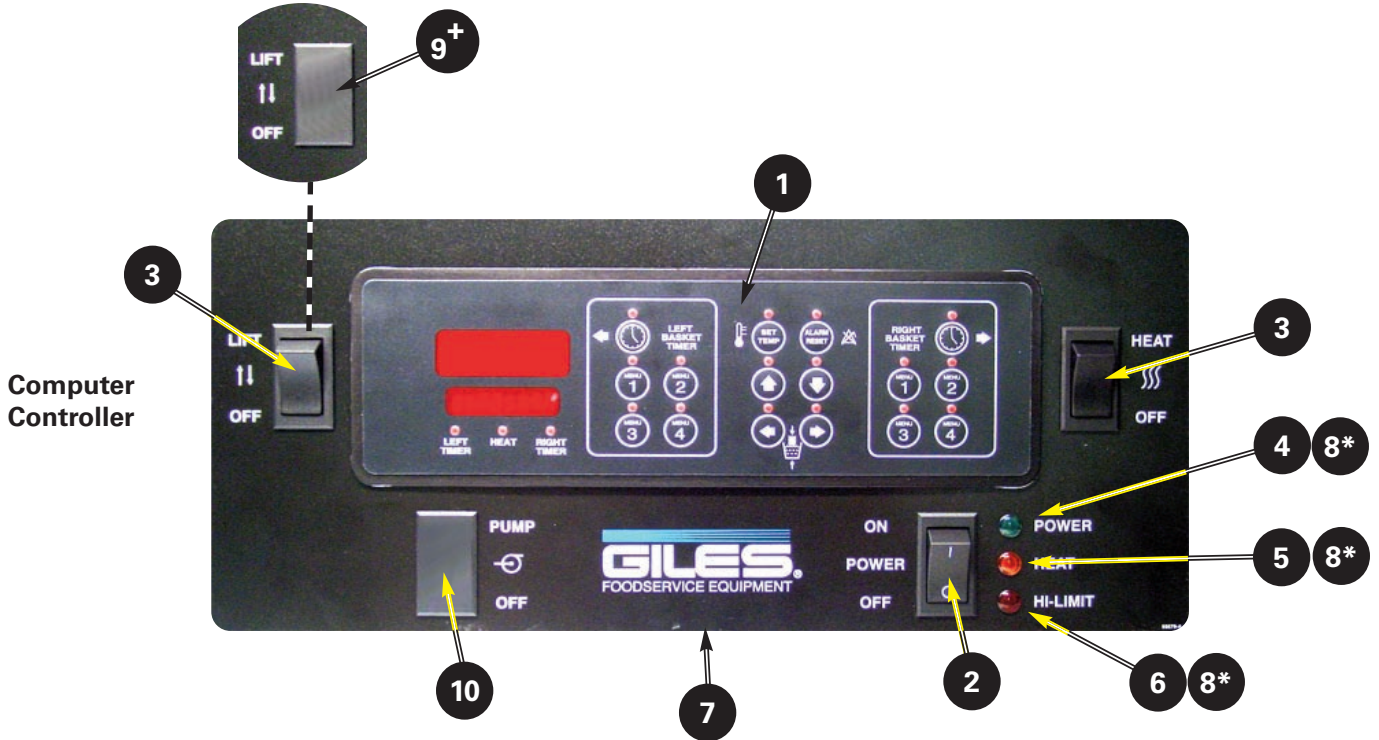

* Not Shown
 † Switch location is plugged on Units without Basket Lift Option

8.03 Control Panel (Computer & Mechanical): Add-On Units for "Banked" Battery

ITEM	PART NO.	QTY	DESCRIPTION
1	20326	1	CONTROLLER, N7, WATLOW
2	21190	1	SWITCH, ROCKER, ON-OFF, 250V, 20A, DPST
3	21052	2 or 1	SWITCH, ROCKER ,ON-OFF-ON, 250V, 20A, DPDT
4	20398	1	INDICATOR LIGHT, GREEN, 250VAC
5	20399	1 or 3	INDICATOR LIGHT, ORANGE, 250VAC
6	20402	1 or 2	INDICATOR LIGHT, RED, 250VAC
7	65676	1	LABEL, CONTROL PANEL, GBF
8*	20307	3 or 6	RETAIN CLIP, INDICATOR LIGHTS
9†	20621	1	PLUG, SWITCH CUT-OUT (For Units <u>WITHOUT</u> Basket Lift Option)
10	20621	1	PLUG, SWITCH CUT-OUT (No Pump)
11	20484	1	CONTROLLER, TEMPERATURE, WATLOW CV, 0-375°F
12	24240	2	TIMER, 30-MIN, MECHANICAL, DIEHL
13	20109	1	SWITCH, PUSH-BUTTON, 250V, 10A, N.C.
14	65872	1	LABEL, CONTROL PANEL, GBF, MECHANICAL TIMERS

* Not Shown

† Used on Units without Basket Lift Option

8.04 Lower Cabinet: Single Unit or Main Unit of "Banked" Battery

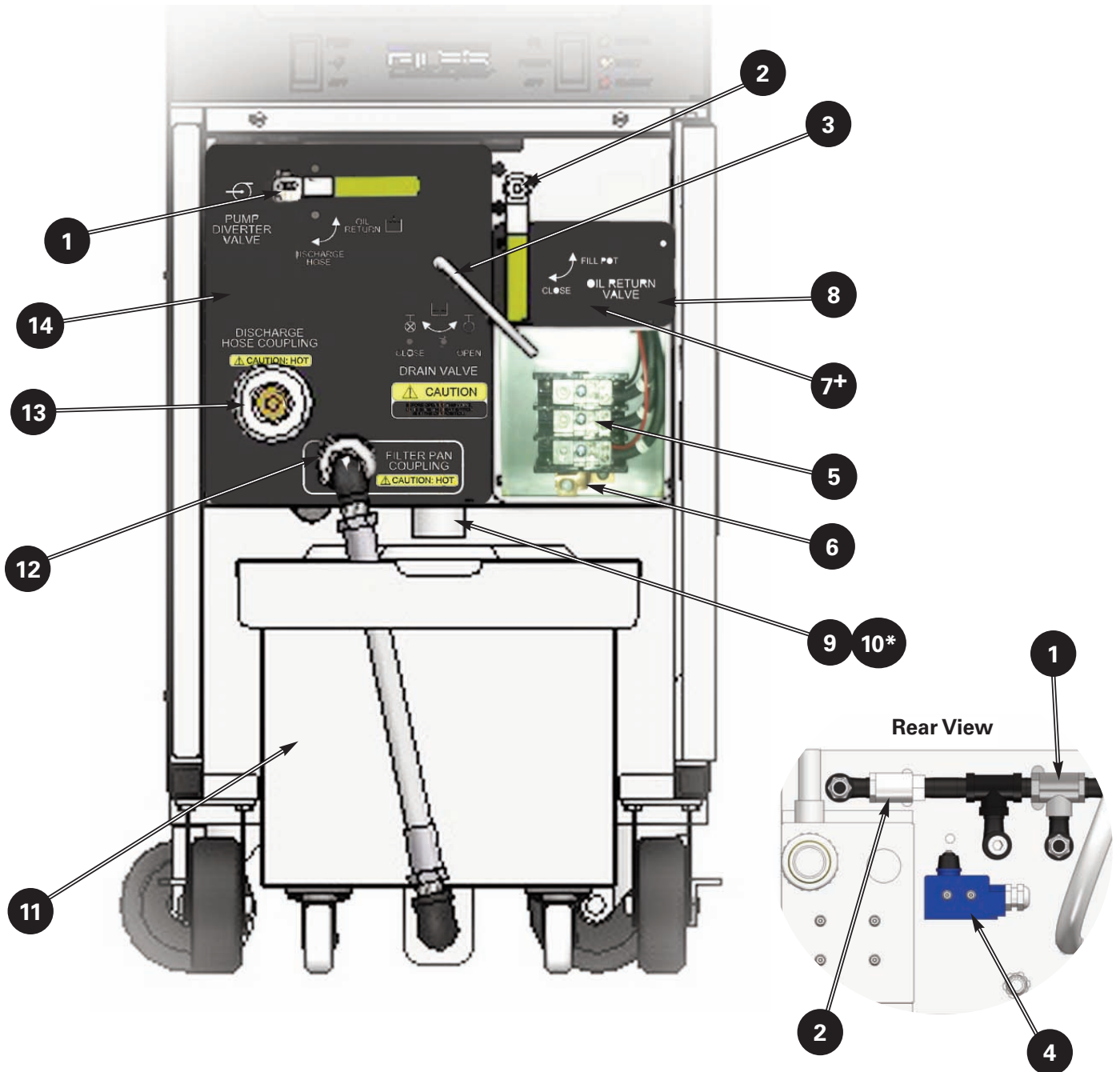

* Not shown
 + Only partially shown



8.04 Lower Cabinet: Single Unit or Main Unit of "Banked" System

ITEM	PART NO.	QTY	DESCRIPTION
1	45755	1	DIVERTER VALVE, 3-WAY, 1/2-NPT, NICKEL PLATED
2	40784	1	BALL VALVE, 1/2-NPT, STAINLESS w/TEFLON SEALS
3	92784	1	DRAIN VALVE HANDLE WELD ASSEMBLY
4	21157	1	DRAIN VALVE LIMIT SWITCH, 15A, 250V
5	21164	1	TERMINAL BLOCK, POWER DISTRIBUTION
6	21051	1	GROUND LUG
7+	92766	1	COVER, ELECTRICAL SERVICE ENTRANCE (REQUIRES ITEM #8, IF REPLACED)
8	65678	1	LABEL, SERVICE ENTRANCE COVER, TOP-HALF
9	93013	1	DRAIN TUBE WELD ASSEMBLY
10*	41106	1	VALVE, DRAIN, 1-1/2 NPT X 1-1/2 TUBE, SS (DRILLED & TAPPED))
11	92627	1	COMPLETE FILTER PAN ASSEMBLY w/COVER
12	41900	1	QUICK-DISCONNECT FITTING, FEMALE, FILTER PAN CONNECTION
13	41699	1	QUICK-DISCONNECT FITTING, FEMALE, DISCHARGE HOSE
14	65673	1	LABEL, FRONT BRACE, SINGLE-MAIN UNIT

* Not shown

+ Only partially shown

8.05 Lower Cabinet: Add-on Unit of "Banked" Battery

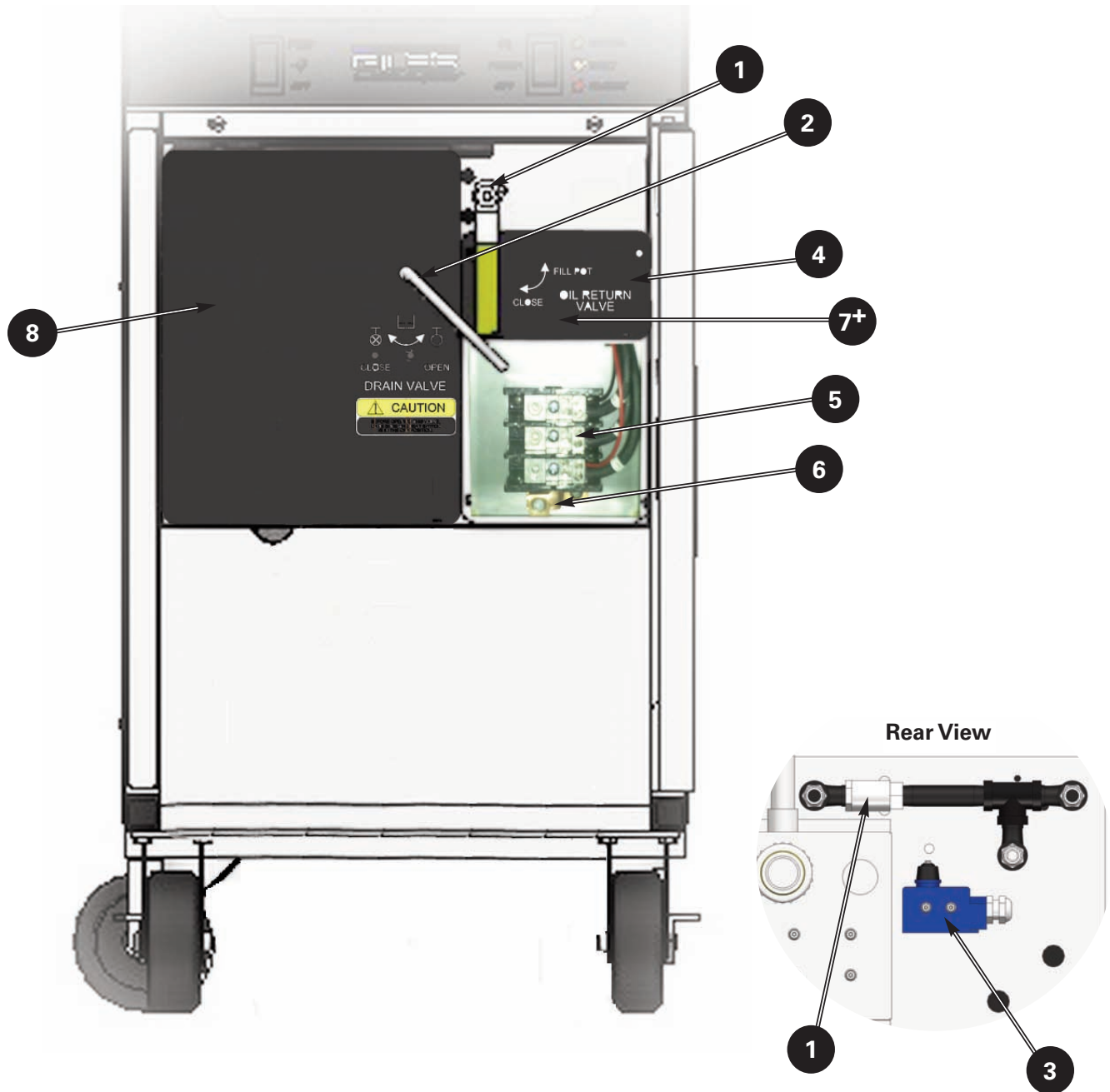

* Not shown
 + Only partially shown



8.05 Lower Cabinet: Add-on Unit of "Banked" Battery

ITEM	PART NO.	QTY	DESCRIPTION
1	40784	1	BALL VALVE, 1/2-NPT, STAINLESS w/TEFLON SEALS
2	92784	1	DRAIN VALVE HANDLE WELD ASSEMBLY
3	21157	1	DRAIN VALVE LIMIT SWITCH, 15A, 250V
4	65678	1	LABEL, SERVICE ENTRANCE COVER, TOP-HALF
5	21164	1	TERMINAL BLOCK, POWER DISTRIBUTION
6	21051	1	GROUND LUG
7+	92766	1	COVER, ELECTRICAL SERVICE ENTRANCE (REQUIRES ITEM #4, IF REPLACED)
8	65674	1	LABEL, FRONT BRACE, ADD-ON BANKED UNITS

* Not shown
 + Only partially shown

8.06 Control Box, Front (Control Panel)

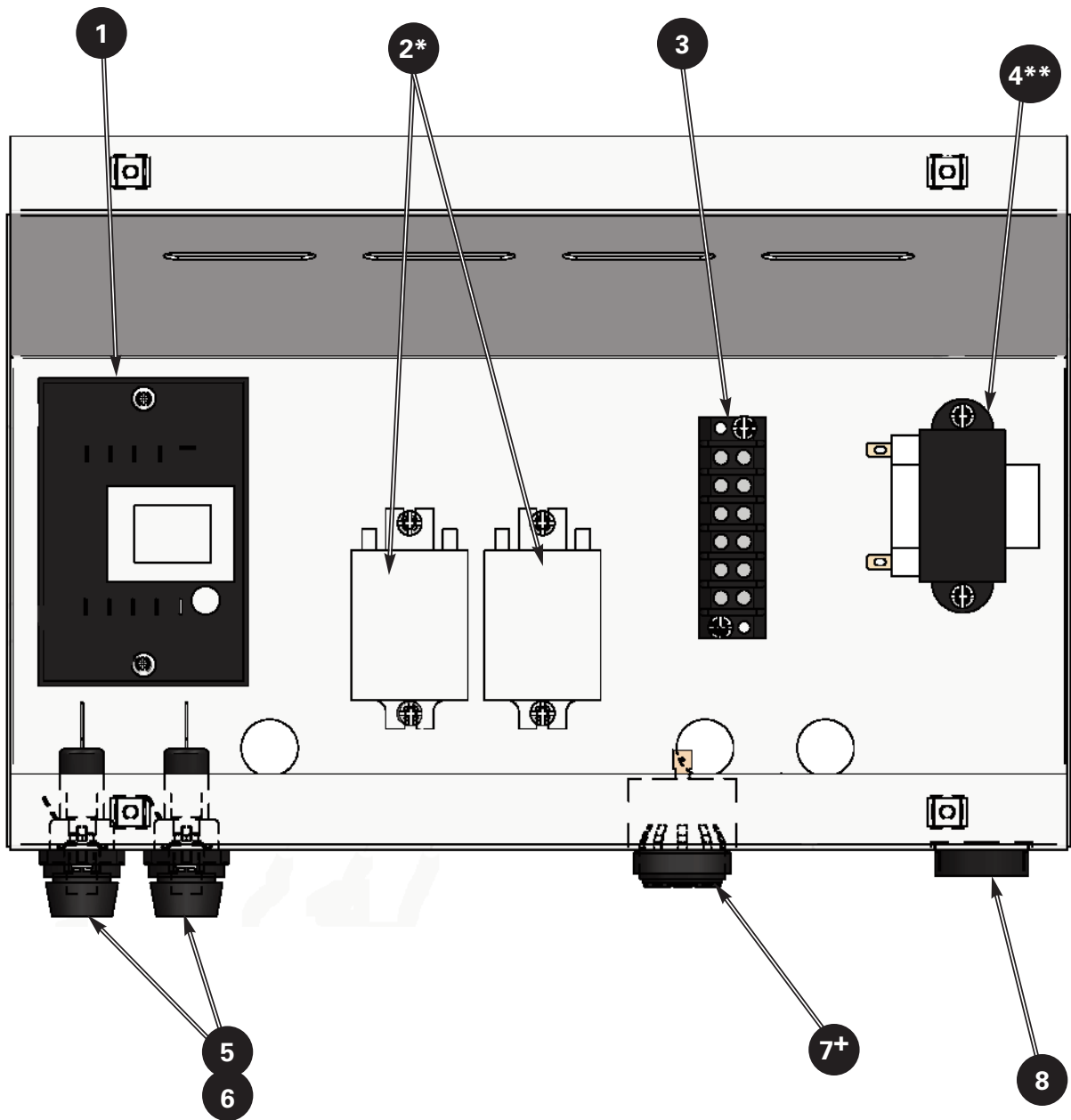

* Present ONLY on units with Mechanical Timers
 ** Present ONLY on units with Computer Controller
 † Two (2) required for units with Mechanical Timers

8.06 Control Box, Front (behind Control Panel)

ITEM	PART NO.	QTY	DESCRIPTION
1	23755	1	HI-LIMIT CONTROL BOARD, 425°F
2*	20618	2	RELAY, DPDT, 240V, BRACKET MOUNT (Mechanical Timer Only)
3	23751	1	TERMINAL BLOCK
4**	20366	1	TRANSFORMER, 9VA/18VA, 115/230 V, 50/60 Hz (Computer Controller Only)
5	21950	2	FUSE HOLDER, 300V, 15A
6	21900	2	FUSE, 15A, BUSS SC-15
7†	23782	1 or 2	SONALERT, 250V, CONTINUOUS TONE (2 Required for Mechanical Timer Only)
8	40550	1	PLASTIC BUSHING, 1-1/4"

* Present ONLY on units with Mechanical Timers
 ** Present ONLY on units with Computer Controller
 † Two (2) required for units with Mechanical Timers

8.07 Rear Cabinet: Single Unit

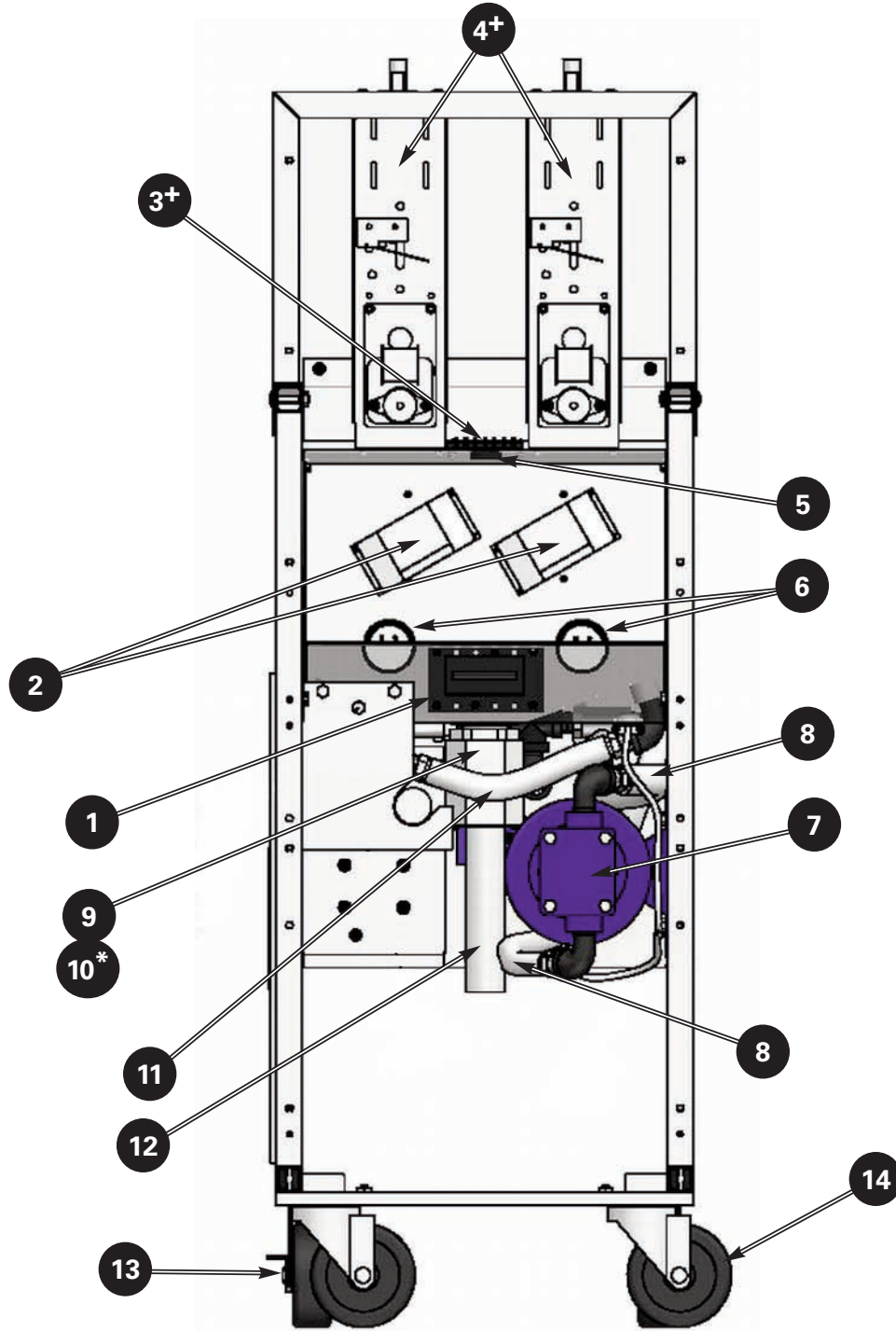

* Not Shown

+ Optional - installed with Basket Lift Option only

8.07 Rear Cabinet: Single Unit

ITEM	PART NO.	QTY	DESCRIPTION
1	20513	1	CIRCUIT BREAKER, 6-POLE (208 - 240V/60 Hz Models)
1	20622	1	TERMINAL BLOCK, DISTRIBUTION, 3-POLE (380 - 415V/50 Hz Models Only)
1	20623	1	TERMINAL BLOCK, DISTRIBUTION, ADD-ON (380 - 415V/50 Hz Models Only)
2	20617	2	CONTACTOR, 50A, 3-POLE (208 - 240V/60 Hz Models)
2	20624	2	CONTACTOR, 50A, 4-POLE (380 - 415V/50 Hz Models Only)
3 ⁺	23751	1	TERMINAL BLOCK (Installed Only with Lift Option)
4 ⁺	35166	2	BASKET LIFT ASSEMBLY (OPTIONAL)
5	40550	1	PLASTIC BUSHING, SNAP-IN, 1-1/4"
6	40792	2	PLASTIC BUSHING, SNAP-IN, 2"
7	70912	1	PUMP & MOTOR ASSEMBLY
8	41080	2	HOSE, CORRUGATED, SS, 1/2" I.D. x 20"
9	41106	1	DRAIN VALVE, SS, 1-1/2 NPT X 1-1/2 TUBE FIT
10 [*]	40820	1	"O" RING, DRAIN VALVE, 1-1/2" I.D. x 0.188"
11	41079	1	HOSE, CORRUGATED, SS, 1/2" I.D. x 8"
12	93013	1	DRAIN TUBE WELD ASSEMBLY, STRAIGHT
13	40806	2	5" CASTER, RIGID, LOCKING, PLATE MOUNT (Front)
14	40807	2	5" CASTER, SWIVEL, NON-LOCKING, PLATE MOUNT (Rear)

* Not Shown

+ Optional - installed with Basket Lift Option only

8.08 Rear Cabinet: "Banked" Battery

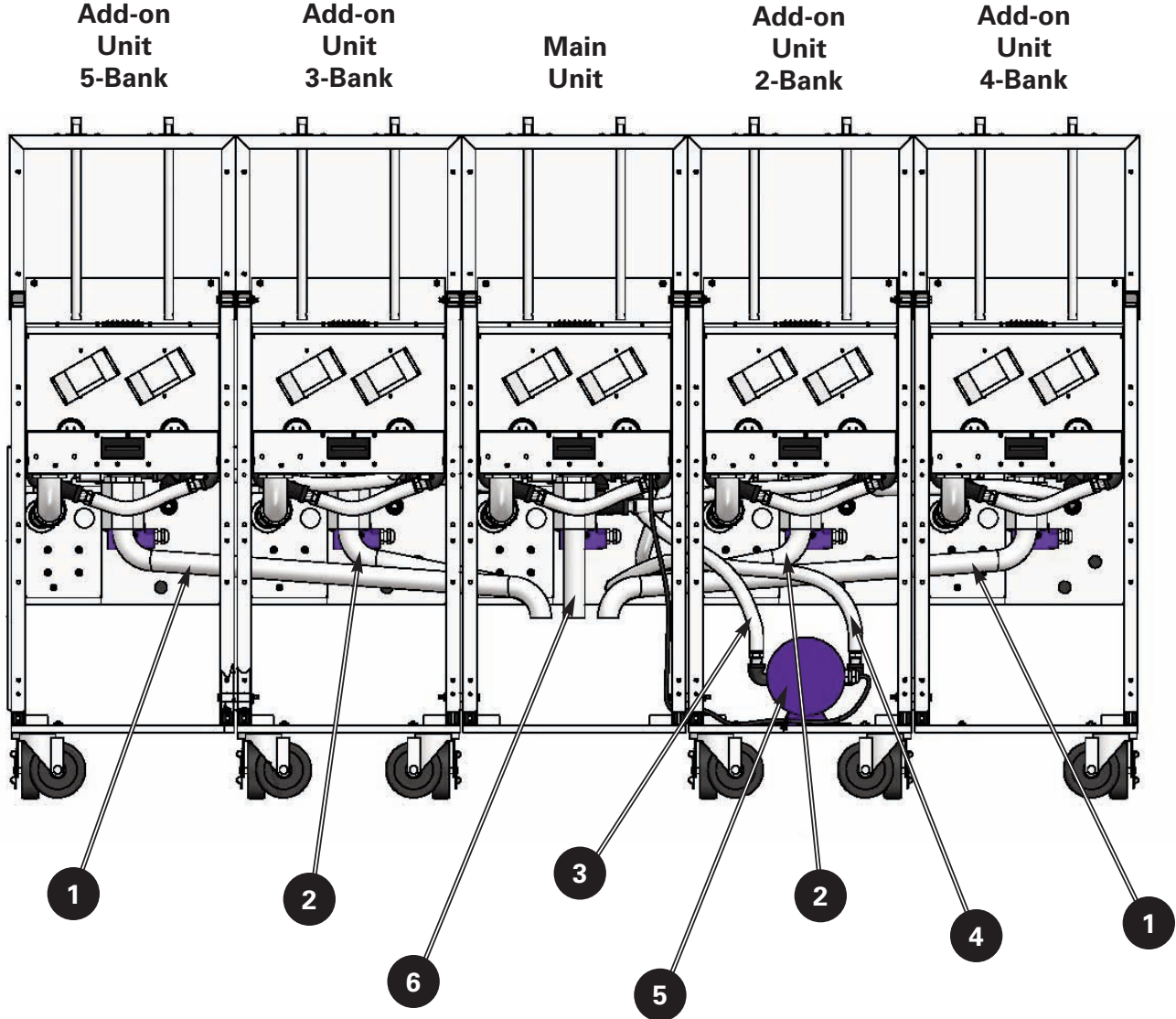



8.08 Rear Cabinet: "Banked" System

ITEM	PART NO.	QTY	DESCRIPTION
1	92827	1 or 2	DRAIN TUBE WELD ASSEMBLY, LONG (Required ONLY for 4 or 5-Bank units)
2	92825	1 or 2	DRAIN TUBE WELD ASSEMBLY, SHORT (Required ONLY for Banked units)
3	41119	1	HOSE, CORRUGATED, SS, 1/2" I.D. x 24"
4	41081	1	HOSE, CORRUGATED, SS, 1/2" I.D. x 30"
5	70912	1	PUMP & MOTOR ASSEMBLY
6	93013	1	DRAIN TUBE WELD ASSEMBLY, STRAIGHT

8.09 Cabinet Underside - "Banked" Battery

Banked systems may be configured with 2, 3, 4 or 5 fryer units

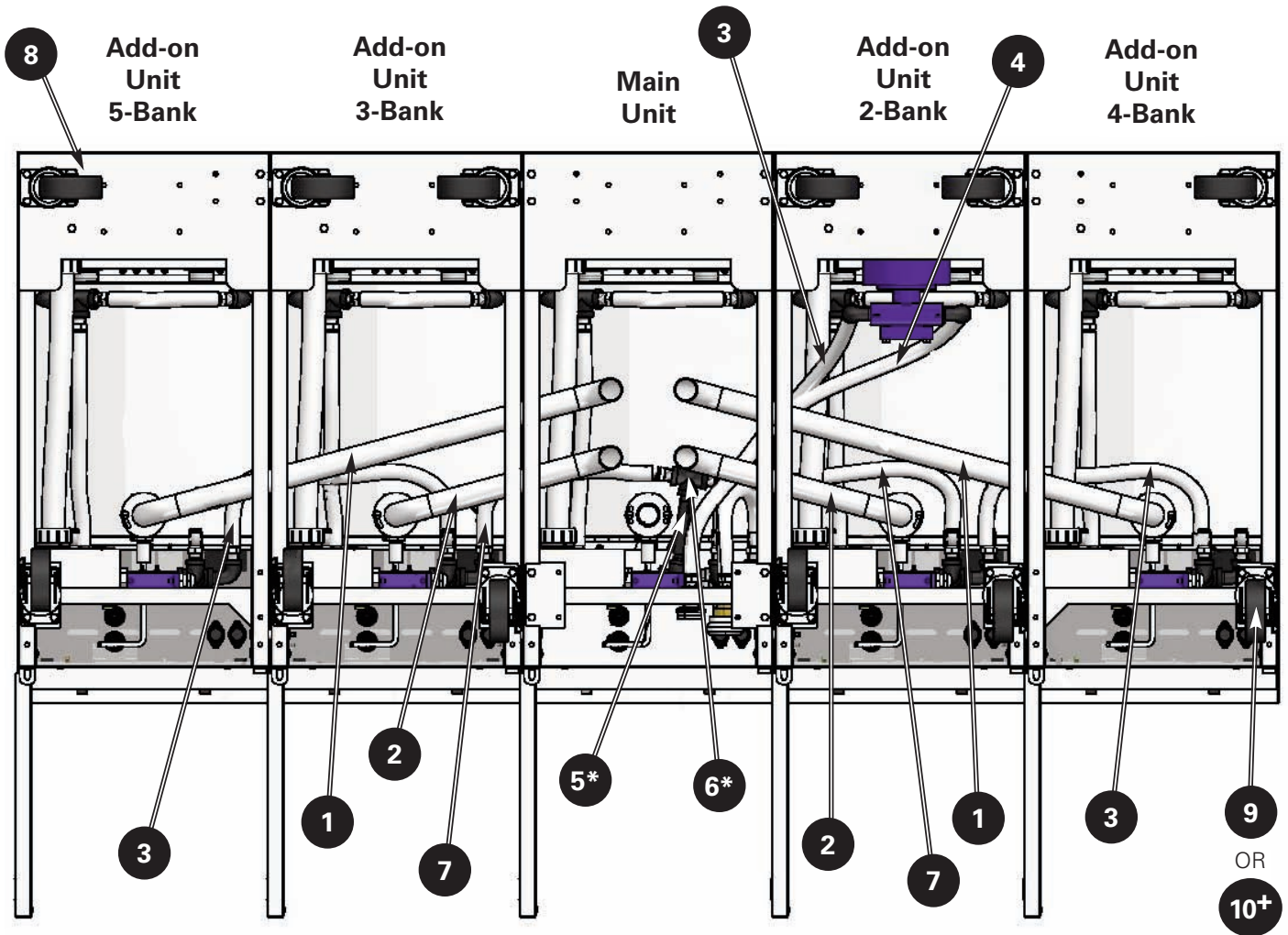

+ 2-Bank Configuration ONLY

* Used ONLY on "Banked" Fryer Batteries

8.09 Cabinet Underside - "Banked" Battery

ITEM	PART NO.	QTY	DESCRIPTION
1	92827	1 or 2	DRAIN TUBE WELD ASSEMBLY, LONG (Required ONLY for 4 or 5-Bank units)
2	92825	1 or 2	DRAIN TUBE WELD ASSEMBLY, SHORT (Required ONLY for Banked units)
3	41119	**	HOSE, CORRUGATED, SS, 1/2" I.D. x 24"
4	41081	1	HOSE, CORRUGATED, SS, 1/2" I.D. x 30"
5*	31436	1	NIPPLE, BLACK PIPE, 1/2 X 5"
6*	40296	1	TEE, BLACK PIPE, 1/2"
7	41080	**	HOSE, CORRUGATED, SS, 1/2" I.D. x 20"
8	40807	**	REAR CASTER, 5" SWIVEL, NON-LOCKING, PLATE MOUNT
9	40700	**	FRONT CASTER, 5" SWIVEL, LOCKING, PLATE MOUNT
10+	40806	3	FRONT CASTER, 5" RIGID, LOCKING, PLATE MOUNT (Front)

- ** Qty dependent on "banked" configuration
- + 2-Bank configuration ONLY
- * Used ONLY on "Banked" Fryer Batteries

8.10 Fry Vat Assembly

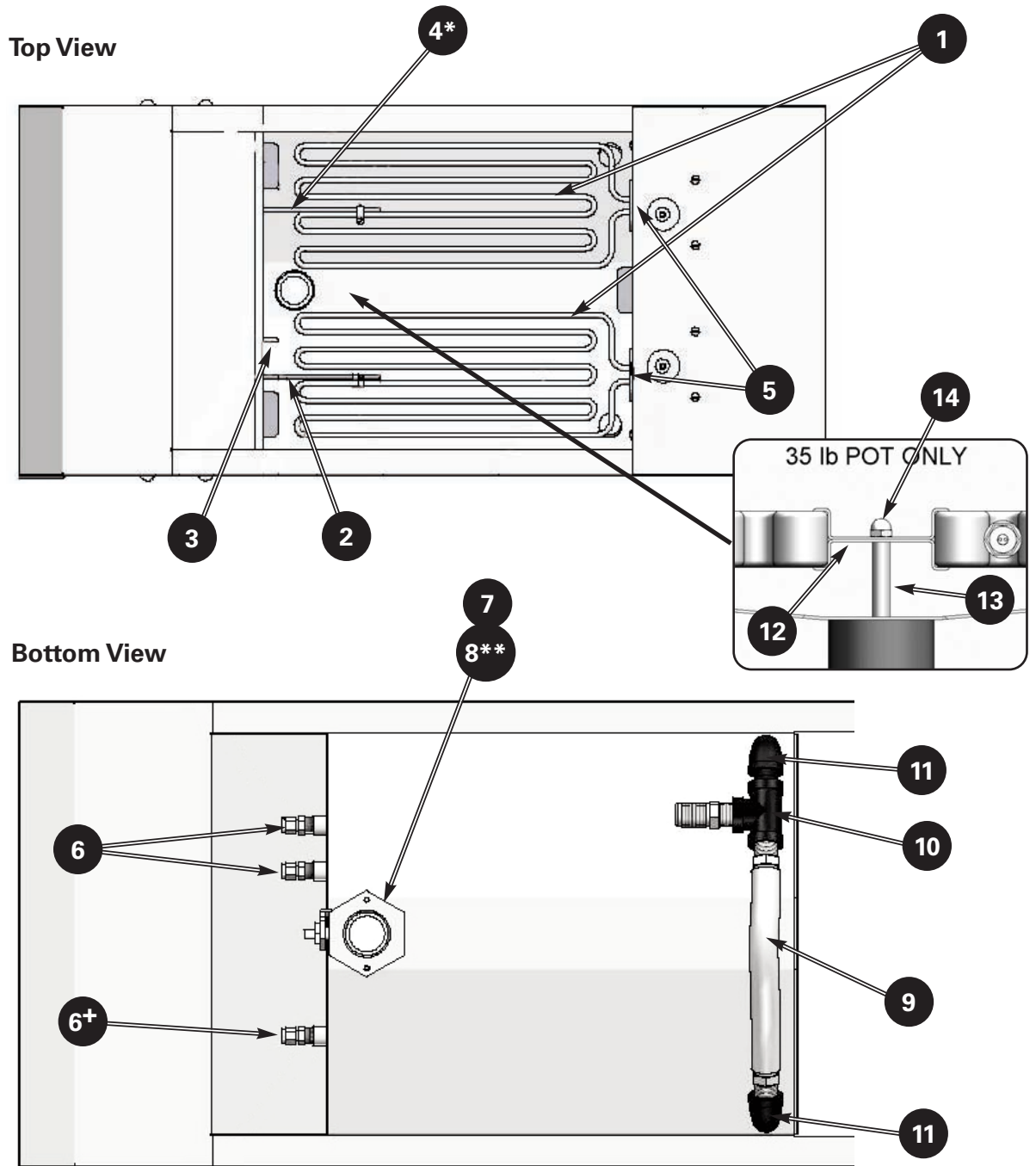

* Not installed on Units with Mechanical Timers
† Fitting is plugged on Units with Mechanical Timers

8.10 Fry Vat Assembly

ITEM	PART NO.	QTY	DESCRIPTION
1	20563	2	ELEMENT, 208 V, 9000 W, FIREBAR
1	20564	2	ELEMENT, 240 V, 9000 W, FIREBAR
2	20613	1	THERMOCOUPLE- J, 7-1/2", GROUNDED (HI-LIMIT PROBE)
3	23900	1	THERMOCOUPLE - J, 3-IN, SINGLE (VAR. OIL TEMP PROBE)
4*	20362	1	THERMOCOUPLE, 7.5 X 0.188, J-TYPE, STR (ELEMENT TEMP PROBE)
5	40513	2	GASKET, ELEMENT, FIREBAR
6	45400	3 or 2	CONNECTOR, 0.190 ID, 1/4 NPT, SWAGELOCK (2 REQUIRED FOR MECH. TIMER UNITS)
7	41106	1	VALVE, DRAIN, 1-1/2 NPT X 1-1/2 TUBE, SS
8**	40820	1	O-RING, DRAIN VALVE
9	41079	1	HOSE, CORRUGATED, SS, 1/2 ID X 8"
10	40296	1	TEE, 1/2 NPT BLACK PIPE
11	42250	2	ELL, BLACK, STREET, 1/2, 90-DEG
12	93324	2	ELEMENT SUPPORT BRACKET (GBF-35 ONLY)
13	93325	1	ELEMENT SUPPORT POST (GBF-35 ONLY)
14	10532	1	NUT, ACORN, 10-32, S/S (GBF-35 ONLY)

* Not installed on Units with Mechanical Timers

** Not Shown

8.11 Filter Pan

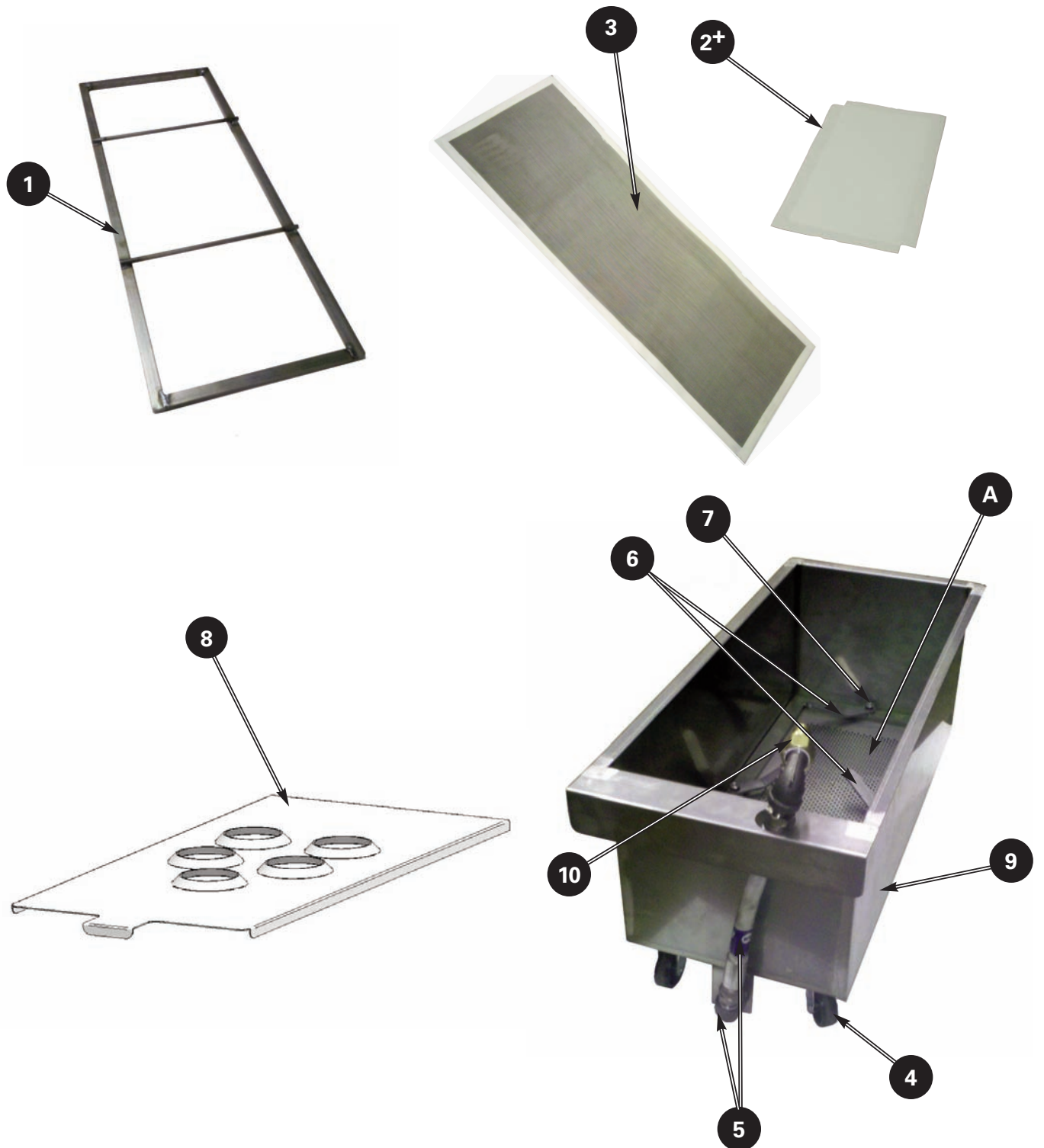

8.11 Filter Pan

1	92623	1	HOLD-DOWN FRAME
2+	65781	1	FILTER PAPER MEDIA; PAN REQUIRES (1) SHEET (Supplied as Case of 100 Sheets)
3	41078	1	FILTER SCREEN, REUSABLE, STAINLESS STEEL, MICRO-MESH (Standard w/purchase)
4	40649	4	SWIVEL CASTER, 2-1/5", PLATE MOUNT
5	41073	2	HOSE, 1/2 NPT x 12-1/2" FLEX w/SWIVEL FITTINGS (Bottom Hose not seen)
6	38841	4	HOLDDOWN FRAME LOCKING HANDLE
7	30040-4	4	STUD, HOLDDOWN FRAME LOCKING HANDLE
8	93010	1	FILTER PAN COVER
9	92627	1	COMPLETE FILTER PAN ASSEMBLY (Including COVER)
10	44150	1	QUICK-DISCONNECT FITTING, MALE, BRASS

+ Optional Usage - Stainless Steel Filter Screen (SSFS) is standard with fryer purchase

Note: The perforated plate **A** in the Filter Pan bottom is **NOT** a filter! It **ONLY** serves as support for the filter media and safeguards against allowing excessively large crumbs or debris from unintentionally entering the filtration system. Filter media must be used for filtering oil. Failure to utilize proper filter media will void the warranty! This plate is **NOT** a replaceable part.



Notes:





Giles Enterprises, Inc.

P.O. Box 210247 • 2750 Gunter Park Drive West • Montgomery, Al 36121-0247 USA
Phone: 334.272.1457 • Toll Free: 800.554.4537 (USA & Canada Only) • Fax: 334.239.4117 • www.gfse.com
E-mail: services@gfse.com

Form No. 65686 (Release Date: 04/20/11) Rev. C