

Item # \_\_\_\_\_  
 Qty # \_\_\_\_\_  
 Model # \_\_\_\_\_  
 Project # \_\_\_\_\_



**DUKERS**  
 Quality Commercial Refrigeration



# HOT PLATE EIGHT BURNER DCHPB48



Catch Tray



Surface



Legs



## PRODUCT DESCRIPTION

- Stainless steel exterior and interior.
- 32,000 BTU stainless steel burners with standby pilot.
- Lift-off cast iron burner.
- Independent manual controls every 12".
- "Cool-to-the-touch" front s/s edge.
- Each hot plate is shipped with Standard Natural Gas, LP conversion kit.
- Adjustable, stainless steel legs standard.
- Full length seamless drip pan, easy to remove and clean.



## HIGH QUALITY STAINLESS STEEL & ROBUST DESIGN

HOT PLATE MODEL	DIMENSION		
	Width	Depth	Height
DCHPB48	48 in	28 3/4 in	13 3/8 in



Los Angeles | San Francisco | Dallas  
 Houston | Florida | Chicago | New Jersey

1-800-931-8628

@ info@dukersusa.com

www.DukersUSA.com

# DETAILS & SPECIFICATIONS

## HOT PLATE DCHPB48

Top View

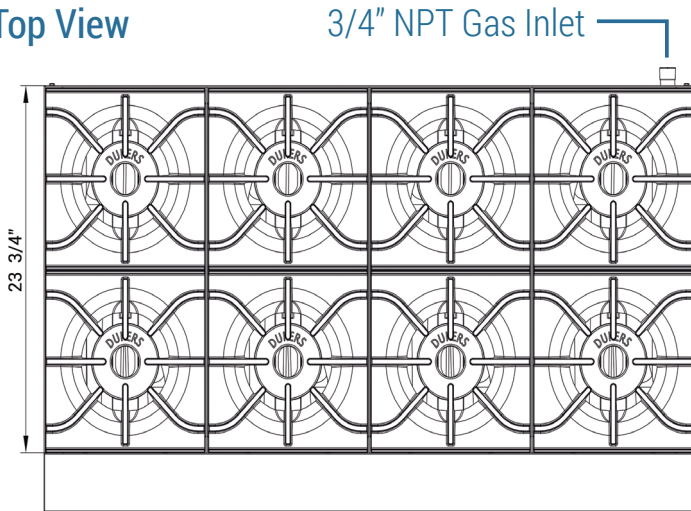

Side View

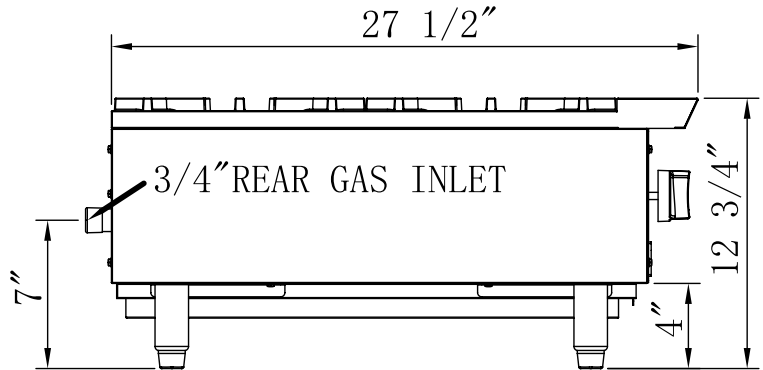

Front View

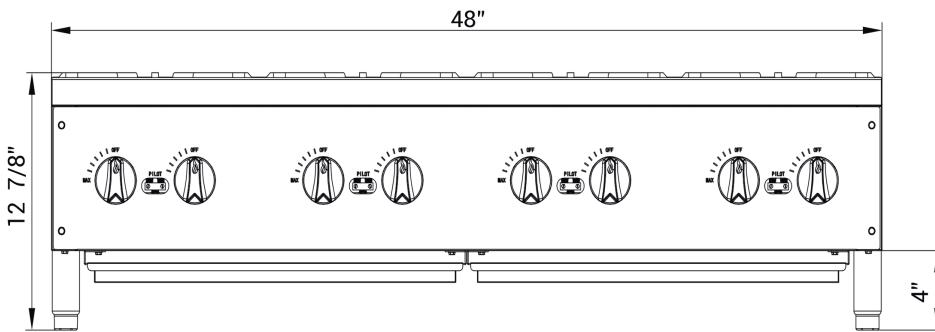

### DCHPB48

GAS SOURCE	NG/Propane
WORK AREA	47.80x23.62in
BURNER	8 count
SINGLE BURNER	32,000 BTU/H
COMBINED	256,000 BTU/H
GAS PRESSURE	NG: 4 "WC Propane: 10 "WC
NOZZEL	NG: 40# Propane: 52#

Model	Packaging Dimensions (inches)			Net Weight (lbs)	Ship Weight (lbs)
	W	D	H		
DCHPB48	50 1/4"	32 5/8"	17 3/4"	198.42	264.56



Los Angeles | San Francisco | Dallas  
Houston | Florida | Chicago | New Jersey

1-800-931-8628

@ info@dukersusa.com

www.DukersUSA.com