



Our business is enhancing  
your business

## Infinity Start 100 Roll-In Blast Chiller



# Infinity Series Blast Chiller

## Standard Product Features:

- 40°C Ambient Rating
- Capacity of (6) Trolley of GN 1/1 Pans or (4) Trolley of GN 2/1 Full Size Pans
- 9" touch control system
- Blast freezing capacity of 1,212 lb and blast chilling capacity of 1,322 lb
- 7 cycles including blast chill, shock freeze, and thaw, which can be automatic or manual
- Multilevel function, defrosting function
- Removable electronic panel for easy maintenance
- Stainless steel AISI 304 construction
- SD card with tutorial videos and USB door for HACCP data download
- Multipoint core probe (4 reading points)

Roll-In Blast Chillers

## Accessories

- Shelves and supports for GN 2/1 and EN 400x600 trays
- Support for 600x800 mm trays
- Trolley for 600x800 mm trays
- Ice cream pans (5L - 360x165xH20mm)

## Options:

- LED lighting system
- EVO-CLOUD connectivity for remote control and monitoring
- Removable air filter for easy cleaning
- Automatic sterilization system for food safety
- Wi-Fi temperature probes for temperature control and monitoring
- Customizable menu with different programs for specific products and cooking styles
- Tracer, a system for monitoring food safety and quality
- Supervisor, a tool for controlling multiple units from one central device

- Chill 1,322 lbs from 194°F to 37°F in 90 minutes.
- Freeze 1,212 lbs from 194°F to -0.4°F in 240 minutes.

WARRANTY  
**5** YEARS  
COMPRESSOR

WARRANTY  
**2** YEARS  
PARTS &  
LABOR



Web: [www.gbsamerica.com](http://www.gbsamerica.com)

Distributed in United States by GBS US Foodservice Equipment, Inc.

E-mail: [Sales@Gbsamerica.com](mailto:Sales@Gbsamerica.com)

Tel: (888) 402-1242



## Infinity Start 100 Roll-In Blast Chiller

Line Drawing & Dimensions

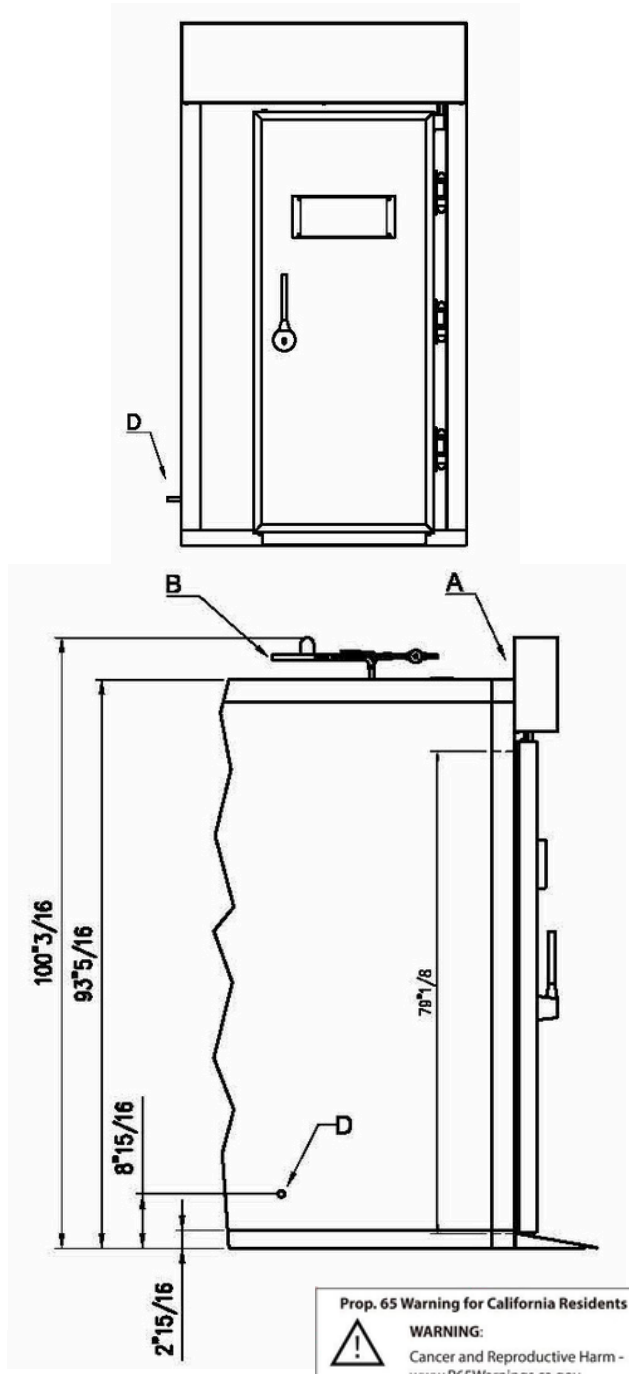
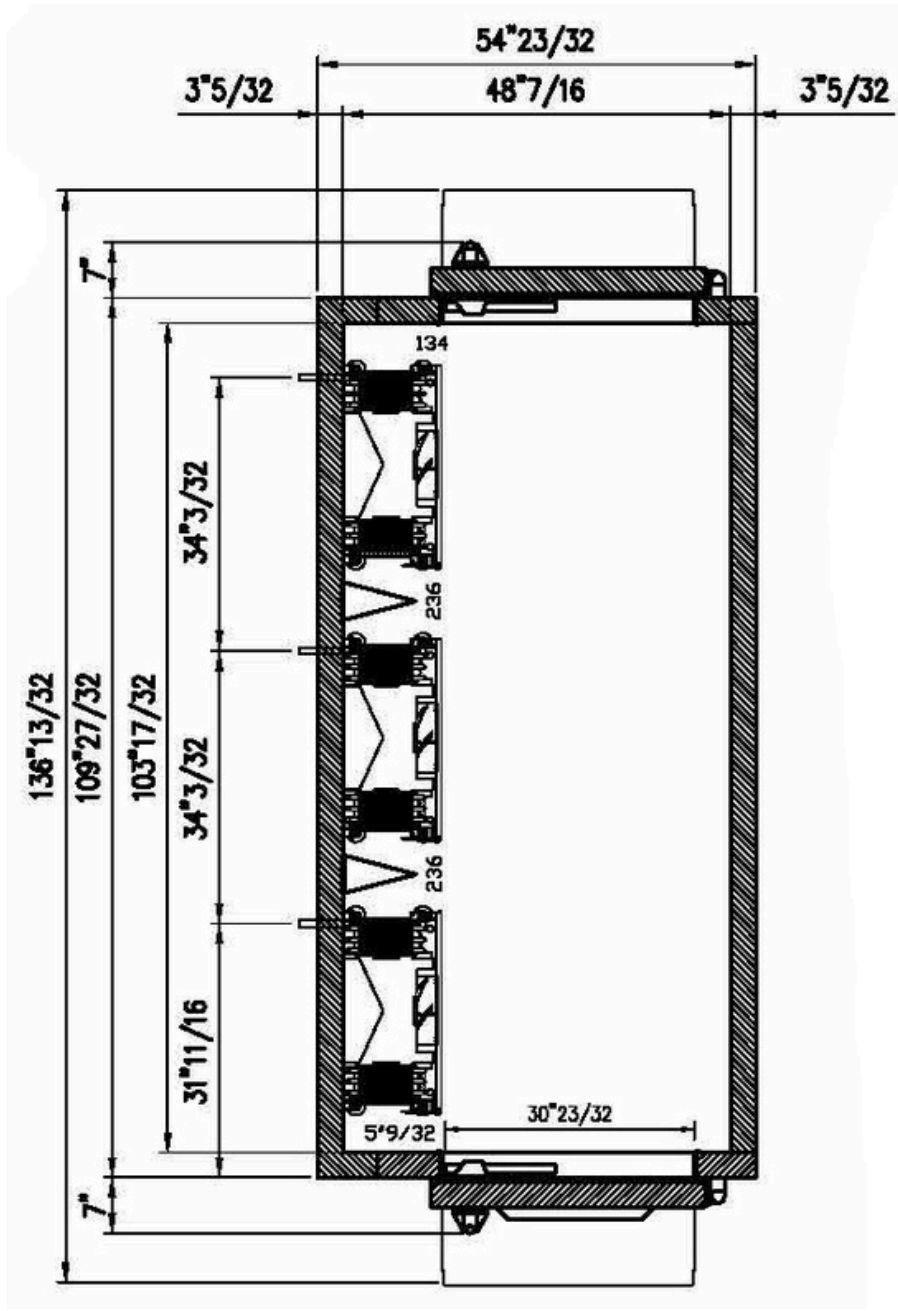

Prop. 65 Warning for California Residents  
 **WARNING:**  
 Cancer and Reproductive Harm - [www.P65Warnings.ca.gov](http://www.P65Warnings.ca.gov)

Web: [www.gbsamerica.com](http://www.gbsamerica.com)

Distributed in United States by GBS US Foodservice Equipment, Inc.

E-mail: [Sales@Gbsamerica.com](mailto:Sales@Gbsamerica.com) | Tel: (888) 402-1242



### Dimensional Data

External Dimensions:	See Drawing
Internal Dimensions:	<b>54.72 x 136.63 x 100.19</b>
Packing Dimensions:	Box: <b>93.31 x 53.53 x 63.00</b>
	Pipes: <b>47.25 x 88.59 x 29.91</b>
	<b>138.59 x 15.75 x 16.34</b>
Insulation Thickness (in):	3.14
Internal Volume (gal):	1089.18
Gross Weight (lbs):	3109
Net Weight (lbs):	2332

### Electrical & Refrigeration Data

Power Supply (V / Ph / Hz):	220 / 3 / 60
Nominal Power Consumption (W):	
Blast Chilling Yield (lbs):	1322
Shock Freezing Yield (lbs):	1212
Compressor:	
Noise (db):	
Maximum Absorbed Current (Amps):	11
Climatic Class:	5
Refrigerating Power (W):	
Gas:	R404A - GWP 3922
Controller:	Touch Screen 9"

### Warranty Information

- 2 Years: Comprehensive coverage on parts and labor.
- 5 Years: Coverage for the compressor.

**Disclaimer:** Continuous product development may require changes to specifications without notice.

**Installation:** The blast chiller must be installed in accordance with the guidelines outlined in the appropriate installation manual. Adhering to the manual's instructions is essential to ensure correct operation and to protect the user's rights under the warranty.

### Equipment Specifications

#### Controller / Basic Operations

Simple, clear and intuitive controls on the TOUCH SCREEN 9", 16 million color display, guide the operator and offer both automatic and manual cycles. Manual operating cycles are designed for the more experienced users who prefer to create their own customized blast chilling settings.

Automatic cycles allow the user to use pre-set programs for many different types of foods.

#### Food Scan with Multi-Point Probe

INFINITY is the only chiller equipped with a multipoint pin probe as standard. The 4 measurement points can detect the exact temperature of food simply and immediately. Even when the probe is inserted entirely correctly, the machine is able to scan the temperature on the four pins, and detect the highest temperature, which will be the reference point in reaching the desired temperature. Furthermore, various options are available, such as the wireless WMP probe or the heated core probe.

#### HACCP Information

Real time HACCP graphics for monitoring temperatures and cycle duration in real time. HACCP reports viewable and downloadable via the USB port to a PC. The HACCP report archive can be back searched up to a year, by simply entering the desired date. By doing this, cycle graphics, timings, minimum and maximum temperatures reached can be consulted and compared. Furthermore, by consulting data relating to consumption, precise calculations of product production costs can be made.

#### Video Options

User Videos assist with cycle set up and machine functions by kitchen personnel, eliminating the cost and time of training. Service Videos give technical support to personnel specialised in maintenance, reducing delays and facilitating service operations.