



Features

Eco-Friendly Refrigerant

R290 refrigerant with a global warming potential (GWP) of 3

Elevated Countertop Compartments

Holds up to three (3) 1/3 size pans and positions key ingredients closer to the crew — pan adapters included

High-Efficiency Refrigeration System

Forced air circulation provides uniform temperature throughout the cabinet

Easy to Clean

Aluminum interior, coved corners, finished edges, removable cutting board, and top compartment crumb tray for simple cleaning

High-Density Insulation

Foamed-in-place, CFC-free polyurethane insulation for maximum strength, rigidity, and insulation

Large Work Surface

15" deep stainless steel work surface for menu assembly — includes bracket for optional cutting board

Drawer Capacity

Each drawer can accommodate one (1) full-size 12" W x 20" H x 6" D hotel pans — pan adapters are available for fractional pans

Stainless Steel Exterior

Galvanized back and bottom to reduce the risk of corrosion

Magnetic 'Thermo Rubber' Gaskets

Heavy-duty, stainless steel doors with magnetic 'Thermo Rubber' gaskets ensure an air-tight cabinet

Heavy-Duty Soft Casters

Secured to a 12 gauge steel base to ensure years of worry-free operation

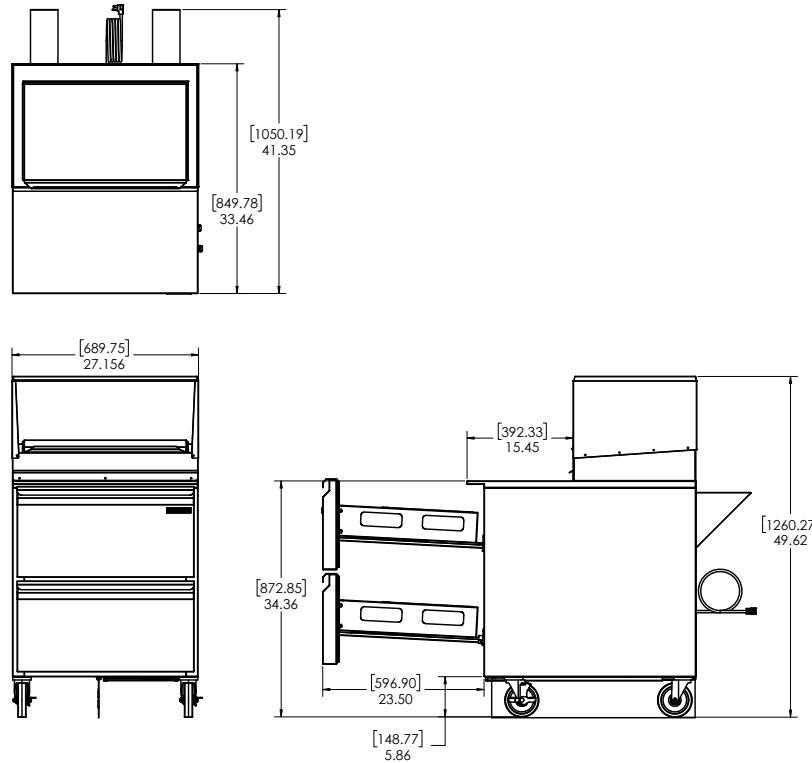

Technical Specifications

Electrical Requirements	115v/60hz/1ph/2.7A/NEMA 5-15P Plug
Product Dimensions	27.16"W x 49.62"H x 41.35"D (68.99cm x 126.03cm x 105.03cm)
Product Weight	265lbs (120.20kg)
Shipping Dimensions	31"W x 51"H x 40"D (78.74cm x 129.54cm x 101.60cm)
Shipping Weight	280lbs (127.01kg)
Shipping Cubic Dimensions	36.6ft ³ (1.04Cu.M ³)
Temperature Range	-5 to 5°F (2.2 to 4.4°C)
Refrigerant	R290
Insulation	Foamed-in-place, CFC-free polyurethane
Exterior Construction	Stainless steel exterior with galvanized bottom

Interior Construction	Aluminum interior with coved corners and finished edges
Drawers	Two (2) high-strength, full-extension drawers with dividers
Lid	Removable flat stainless steel (with rear heat shield)
Pan Well Capacity	Supplied with three (3) 1/3 size pans (6" deep)
Drawer Capacity	Supplied with two (2) 1/6 size pans (6" deep) and eight (8) 1/3 size pans (6" deep)
Drawer Gasket	Santoprene™ gasket
Cutting Board	Accommodates custom cutting board
Casters	Four (4) 5" heavy-duty soft casters (two locking)
Certifications	ETL SAFETY, ETL SANITATION
Warranty	1-year parts and labor, 5-year compressor (part only)

Model Number	Description
SKPZ27-EDUS1	Prep Table, 27", 115v/60hz/1ph, 2 drawer, 5" heavy-duty casters (two locking), upper heat shield compartment, condenser filter, NEMA 5-15P

Accessories	Description
25567	Adapter Bars for Fractional Pans
43581	Pan 1/6 Size, 4" Deep Plastic
43643	Pan 1/6 Size, 6" Deep Plastic
27066	Pan 1/3 Size, 4" Deep Plastic
26415	Pan 1/3 Size, 6" Deep Plastic

To learn more about **Silver King Pizza Prep Table**, visit silverking.com