

MADE IN GREECE



Models:
1510 / 500

Standard Features

- 304 Stainless Steel Handle and Body
- High Temp with Booster
- IP 44 Washing Pump: Peristaltic Rinse Aid & Detergent Pump
- Self Cleaning function
- 3 Washing Programs
- Malfunction Self-Diagnose
- Automatic Draining Pump
- Thermo-protector feature
- Standard Pressure Reducer Valve (PRV)
- Tank & Boiler Thermometer

1510

- Capable of washing GN 1/1 pan
- Stainless-Steel Washing Nozzles

500

- Steady Upper Washing Nozzles for more efficiency
- Stainless-Steel Wash & Rinse Group



1510



500

1-year parts and labor warranty (US Only)

SPECIFICATIONS		
	1510	500
Motor Power (Hp)	1 1/2	3/4
Type	Door Universal	Undercounter Front Loading
Basket Dimension	20" x 20"	20" x 20"
Door Clearance	15.75"	14.17"
Length of Cycle	60/120/180 sec**	60/120/180 sec**
Baskets/Hour	30	20/30/60 **
Glasses/Hour	1470	735/1470/2205
Dishes/Hour	540	270/540/810
Tank Capacity	15 Gal (56.8 L)	9.2 Gal (35 L)
Boiler Capacity	2 Gal (7.6 L)	1.6 Gal (6.1 L)
Power Supply	220V/60HZ/1ph	220V/60HZ/1ph
Power (kW)	8.6	3.6
Amps	39.1	16.4
Plug / Connection	Wire - No plug	
Product Dim. (WxDxH) DOOR CLOSED	29.5" x 34.6" x 54.7"	22.4" x 23.6" x 32.7"
Product Dim. (WxDxH) DOOR OPENED	29.5" x 34.6" x 72"	22.4" x 37.8" x 32.7"
Product Weight (lbs)	291	122
Shipping Dim. (WxDxH)	30" x 36" x 61"	24" x 28" x 40"
Shipping Weight (lbs)	327	133

**Depends on Program Selection



Notes:

- Properly clean and dry after daily use to ensure best performance and equipment longevity.



Wired No Plug



Direct Water Connection



Drain Required

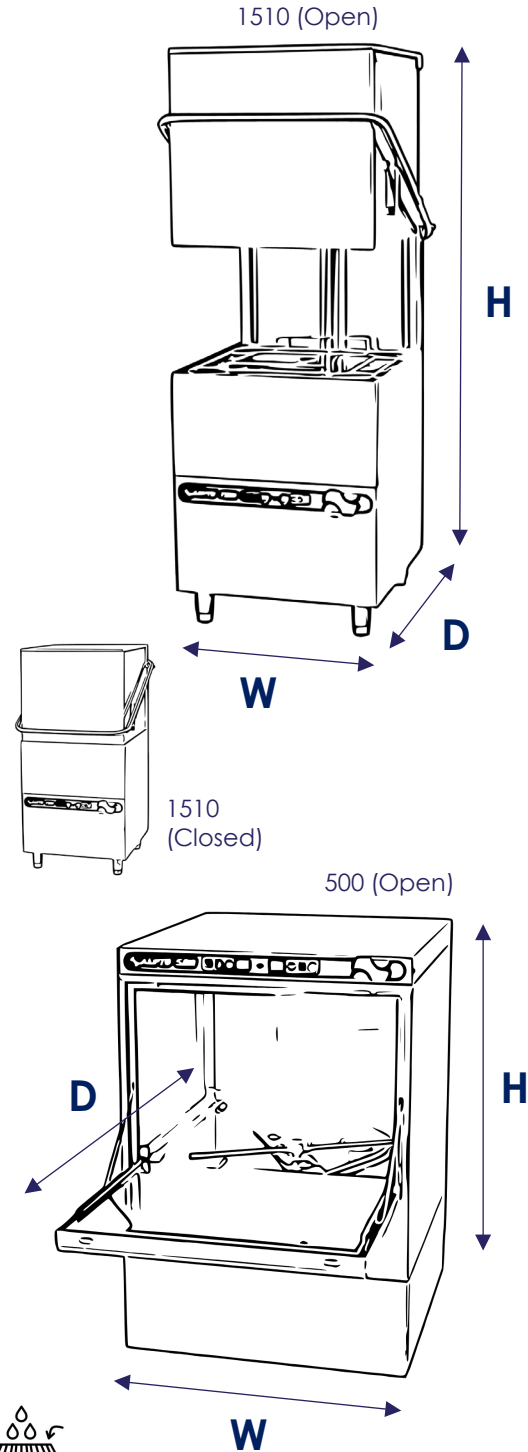

AMPTO is continuously improving products. Specifications are subject to change without notice.