



DFG-200-ES

**Full-Size, Bakery Depth
Dual Flow Gas Convection Oven**



Shown with optional casters

OPTIONS AND ACCESSORIES

(AT ADDITIONAL CHARGE)

- **Legs, casters & stands**
 - 6" (152mm) seismic legs
 - 6" (152mm) casters
 - 4" (102mm) low profile casters (double only)
 - 25" (635mm) stainless steel stand w/rack guides
 - 29" (737mm) stainless steel, fully welded open stand with pan supports
- **Controls**
 - SSI-M - Solid state infinite control w/manual timer
 - SimpleTouch - NEW touchscreen control with ability to store and group recipes. Includes rack timing, Cook&Hold, Fan Delay, Fan Pulse, and HACCP storage capability
- **Gas hose w/quick disconnect restraining device:**
 - 48" (1219mm) hose
 - 36" (914mm) hose
- Stainless steel oven liner
- Extra oven racks
- Stainless steel solid back panel
- Gas manifold (for double sections)
- Prison package (includes security control panel and stainless steel back)
- Flue connector
- Direct vent

OPTIONS AND ACCESSORIES

(AT NO ADDITIONAL CHARGE)

- Solid stainless steel doors

Project _____

Item No. _____

Quantity _____

Extra depth baking compartment - accepts five 18" x 26" standard full-size baking pans in left-to-right or front-to-back positions.

All data is shown per oven section, unless otherwise indicated.

Refer to operator manual specification chart for listed model names.

EXTERIOR CONSTRUCTION

- Stainless steel front, top, and sides
- Dual pane thermal glass windows sealed in stainless steel door frames
- Ergonomically friendly, curved aluminum door handle with simultaneous door operation
- Triple-mounted pressure lock door design with turnbuckle assembly
- Ball bearing slide out front control panel for easy servicing
- 1" solid block plus 1" mineral fiber insulation for a total of 2" of insulation

INTERIOR CONSTRUCTION

- Full angle-iron frame
- Easy to clean Oleophobic baking compartment liner (14 gauge)
- Stainless steel combustion chamber
- Single inlet blower wheel
- Five chrome-plated racks, eleven rack positions with a minimum of 1-5/8" (41mm) spacing
- Interior halogen lights

OPERATION

- Direct fired gas system
- Electronic spark ignition control system
- Removable inshot burners
- Internal pressure regulator
- Manual gas service cut-off switch located on the front of the control panel
- Solid state thermostat with temperature control range of 200°F (93°C) to 500°F (260°C)
- Two speed fan motor
- 3/4 horsepower blower motor with automatic thermal overload protection
- Control area cooling fan

STANDARD FEATURES

- Artisan Touchscreen Control with meat probe allows for Manual Cooking, Recipe Cooking, Cook and Hold, Core Probe Cooking, Fan Delay, and Fan Pulse.
- 25" (635mm) adjustable stainless steel legs (for single units)
- 6" (152mm) adjustable stainless steel legs (for double sections)
- Three year parts and two year labor warranty
- Five year limited oven door warranty*

*For all international markets, contact your local distributor.

NOTE: The company reserves the right to make substitutions of components without prior notice



www.blodgett.com

42 Allen Martin Drive, Essex Junction, VT 05452
Phone: (802) 658-6600 | Fax: (802) 864-0183



DFG-200-ES

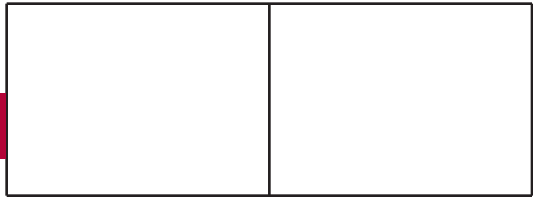

APPROVAL/STAMP

DIMENSIONS ARE IN INCHES (MM)

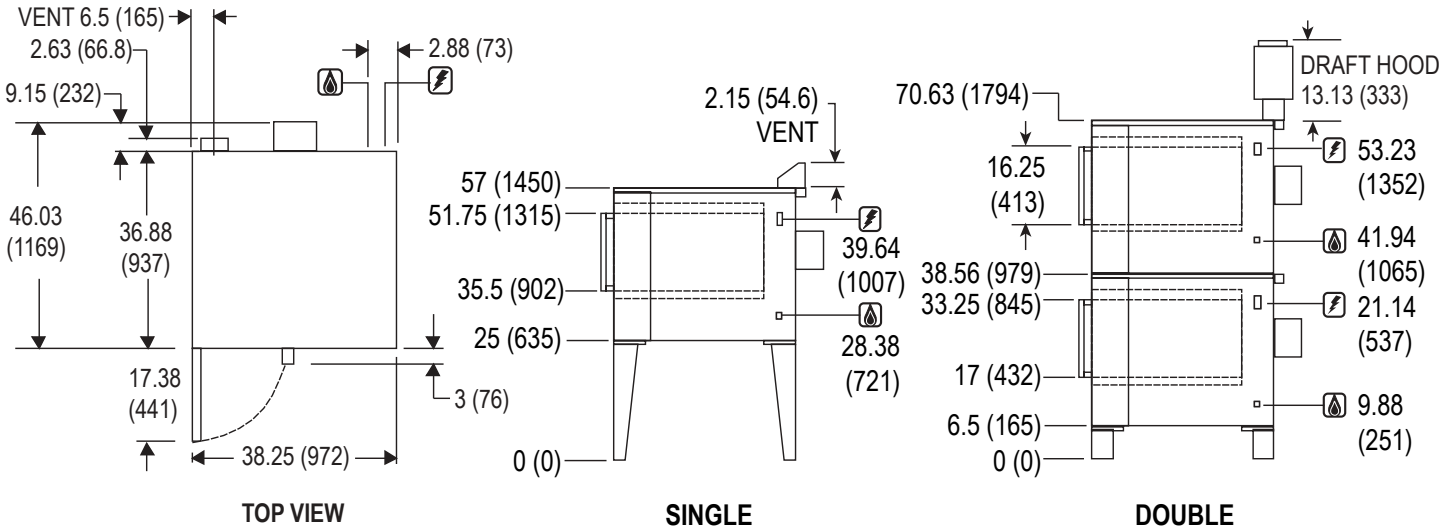

SHORT FORM SPECIFICATIONS Provide Blodgett full-size, bakery depth convection oven model DFG-200-ES, (single/double) compartment. Each compartment shall have Oleophobic 14 gauge steel liner and shall accept five 18" x 26" standard full-size bake pans in left-to-right or front-to-back positions. Stainless steel front, top and sides. Doors shall be (solid stainless steel/dual pane thermal glass windows) with single curved aluminum door handle and simultaneous operation. Unit shall be gas heated with electronic spark ignition and shall cook by means of a direct fired system with a gas shutoff switch on the front of the control panel. Air in baking chamber distributed by single inlet blower wheel powered by a two-speed, 3/4 HP motor with thermal overload protection. Each chamber shall be fitted with two halogen lamps, and five chrome-plated removable racks. Control panel shall be recessed with Artisan Touchscreen Control allowing manual and recipe cooking, cook and hold, probe cooking, fan delay, and fan pulse. Provide three years parts, two year labor and five year door warranty. Provide options and accessories as indicated.

DIMENSIONS

Floor space	38-1/4" (972mm) W x 36-7/8" (937mm) D
Interior	29" (737mm) W x 20" (508mm) H x 24-1/4" (616mm) D
If oven is on casters	
Single	Add 4-1/2" (114mm) to height
Double	Height dimensions remain the same
Double Low Profile	Subtract 2.5" (64mm) from all height dimensions

PRODUCT CLEARANCE

From combustible and non-combustible construction
0" (0)mm

MINIMUM ENTRY CLEARANCE

Uncrated	32-1/16" (814mm)
Crated	37-1/2" (953mm)

SHIPPING INFORMATION

Approx. Weight

Single	617 lbs. (280 kg)
Double	1329 lbs. (541 kg)

Crate Size

37-1/2" (952mm) x 43-1/2" (1105mm) x 51-3/4" (1315mm)
(2 crates required for double)

GAS SUPPLY (per section)

	3/4" NPT
Inlet Pressure	
Natural Gas	7.0" W.C. min. - 10.5" W.C. max.
Propane	11.0" W.C. min. - 13.0" W.C. max.
Manifold Pressure	
Natural Gas	3.5" W.C.
Propane	10" W.C.

MAXIMUM INPUT

50,000 BTU/hr (14.6 Kw) per oven section

POWER SUPPLY

115 VAC, 1 phase, 8 Amp, 60 Hz., 2-wire with ground, 3/4 H.P., 2 speed motor, 1120 and 1680 RPM
6' (1.8m) electric cord set furnished on 115 VAC ovens only
230V CE model, 1 phase, 3 Amp, 50 Hz., 2-wire with ground, 1/2 H.P., 1 speed motor, 1440