



# BEVERAGE-AIR

Project: \_\_\_\_\_  
 Item: \_\_\_\_\_  
 Location: \_\_\_\_\_  
 Approved: \_\_\_\_\_

AIA#

SIS#

**DP72HC FOOD PREPARATION: DELI/PIZZA PREP SERIES**

## FOOD PREPARATION TABLES

### DP72HC Deli/Pizza Two Door Prep Table

Hydrocarbon Series

**MODEL:  
DP72HC**



**7 Year Parts/Labor Warranty**  
**7 Year Compressor Warranty**

#### CABINET CONSTRUCTION

- Stainless steel front, sides, top, doors, and grille (galvanized back & bottom)
- Interior liner is made of corrosion resistant aluminum
- Aluminum top interior liner prevents spill from falling into cabinet
- Stainless steel top
- Removable hoods and insulated lid assemblies are made of matching stainless steel
- Self-closing doors with 120° stay-open feature, on lift-off hinges
- Snap-in door gaskets
- Easy lift-off door removal for service and cleaning
- Field reversible door
- 3" Casters, 2 with brakes standard
- 19" Wide reversible cutting board constructed of white polyethylene plastic
- Cutting board removable for cleaning
- Four (4) epoxy-coated steel wire shelves
- Units will accept pans up to 6" deep (pans are not included)
- Compressor available on left or right, specify at time of unit order

#### OPTIONS & ACCESSORIES

- Stainless steel back
- Stainless steel interior
- Clear lid
- Combination door/drawer models
- Overshelf kits
- Additional shelves
- Shelf clips
- Pan support
- Door locks
- Composite cutting board
- Thermometer
- Night cover
- Bun tray rack
- 6" Casters
- 6" Legs black or seismic/flanged
- Remote option\* (see note on back page)

#### REFRIGERATION SYSTEM

- Uses environmentally friendly, energy efficient R290 refrigerant, and meets all regulatory requirements for CARB, SNAP, DOE & more
- Adaptive defrost
- Epoxy coated evaporator coil
- Enhanced airflow maintains temperatures between 36° - 38°F



Please verify qualifying units by visiting:  
[www.energystar.gov/cfs](http://www.energystar.gov/cfs)

3779 Champion Blvd., Winston-Salem, NC 27105  
 1-888-845-9800 Fax: 1-336-245-6453  
 Beverage-Air.com Sales@bevair.com



# BEVERAGE-AIR

MODEL	DP72HC
<b>EXTERNAL DIMENSIONAL DATA</b>	
Width Overall	72"
Depth Overall with Cutting Board	37"
Height Overall with Casters & Lid Open	53 1/2"
No. of Doors	2
Depth with Door Open 90°	55 1/8"
Door Openings	21 5/8" x 23 5/8"
Depth, Cutting Board	19"
<b>INTERNAL DIMENSIONAL DATA</b>	
NET Capacity (cubic ft.)	21.87
Internal Width Overall (in)	68"
Internal Width Usable (in)	53"
Internal Depth Overall (in)	26"
Internal Height Overall (in)	23 7/8"
No. of Shelves	4
<b>ELECTRICAL DATA</b>	
Full Load Amperes	4.5
<b>REFRIGERATION DATA</b>	
Horsepower	1/2
Capacity (BTU/Hr)	2940
Heat Rejection (BTU/Hr)	4410
Charge (lbs/grams/ounces)	0.231 / 105 / 3.7
<b>SHIPPING DATA</b>	
Gross Weight - Crated	470 lbs
Height - Crated	49"
Width - Crated	78"
Depth - Crated	37"

\*NOTE: Remote units are field wired and come with 6" legs. Refrigerant must be specified at time of order.

We reserve the right to change specifications and product design without notice. Such revisions do not entitle the buyer to corresponding changes, improvements, additions or replacements for previously purchased equipment. Dimensional tolerances +/- 1/4". Metric dimensions (MM).

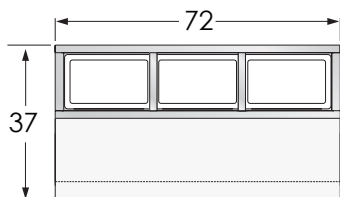

Top Configuration

## Deli/Pizza Preparation Table Model: DP72HC

### Model Views

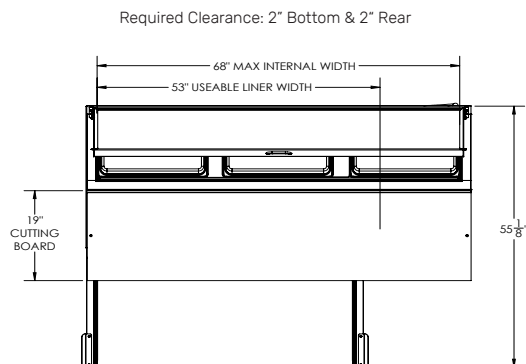

### PLAN VIEW

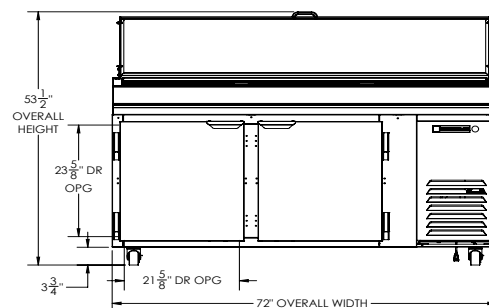

### ELEVATION VIEW

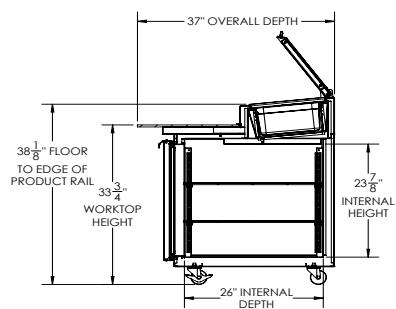

### SIDE VIEW

### ELECTRICAL CONNECTION



115/60/1  
NEMA 5-15P

Unit pre-wired at factory and include 8' long cord and plug set.

