



COMPETITOR SERIES®

PROJECT: _____
 LOCATION: _____
 ITEM#: _____
 QUANTITY: _____



C-42CTS-28



C-56CTS-35



C-70CTS-48

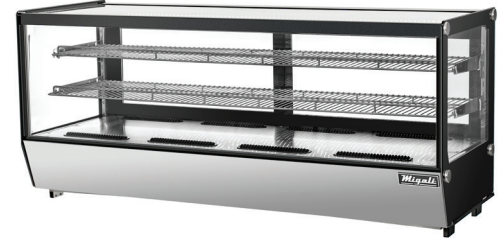

C-88CTS-60

REFRIGERATED COUNTER-TOP DISPLAY CASES, STRAIGHT GLASS

- Beautiful ergonomic construction
- Digital temperature controller & temperature read-out
- All stainless steel interior & exterior front, glass covered black sides
- Double-paned tempered Straight Display Glass
- Glass front, sides and top
- Sliding glass doors in the rear to access the food products
- Forced-air refrigeration system
- LED interior lighting
- Bottom mount compressor
- Auto-defrost system
- Pre-installed feet
- Cantilever, chrome epoxy-plated shelves
- All Natural R290 Hydrocarbon Refrigerant
- US Department of Energy Certified
- Migali® Protection Plan: 2 Year Parts & Labor Warranty, 5 Year Compressor Warranty

MODEL	DOORS	SHELVES	CAPACITY CU/FT	H/P	AMPS	ENERGY CONSUMPTION KWH/24 HR	PLUG TYPE	TEMP RANGE	EXTERIOR DIMENSIONS W X D X H**	INTERIOR DIMENSIONS W X D X H	PACKAGED DIMENSIONS W X D X H**	WEIGHT	PACKAGED WEIGHT
C-42CTS-28	Sliding	2	4.2	1/3	2.7	2.428	Nema 5-15P	+36°F (~) +54°F	27.6 x 22.4 x 27	26.2 x 18.9 x 16.1	30.1 x 24.8 x 28.3	125.7 lbs.	132.2 lbs.
C-56CTS-35	Sliding	2	5.7	1/3	3.0	2.438	Nema 5-15P	+36°F (~) +54°F	34.6 x 22.4 x 27	33.2 x 18.9 x 16.1	37.2 x 24.8 x 28.3	145.5 lbs.	154.3 lbs.
C-70CTS-48	Sliding	2	7.1	4/9	3.9	3.87	Nema 5-15P	+36°F (~) +54°F	48 x 22.4 x 27	46.6 x 18.9 x 16.1	50.5 x 24.8 x 28.3	202.8 lbs.	211.6 lbs.
C-88CTS-60	Sliding	2	8.8	5/9	3.4	4.487	Nema 5-15P	+36°F (~) +54°F	60 x 22.4 x 27	58.6 x 18.9 x 16.1	62.5 x 24.8 x 28.3	230.4 lbs.	246.9 lbs.

FOR COMMERCIAL USE ONLY

NOTE: MIGALI® RESERVES THE RIGHT TO CHANGE SPECIFICATIONS WITHOUT NOTICE



TOLL FREE: 800.852.5292
WEB: www.migali.com



DIMENSIONAL DRAWINGS

C-42CTS-28

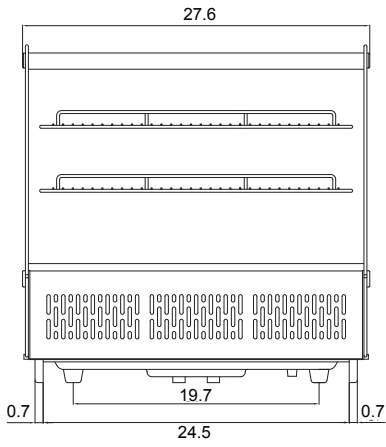

C-56CTS-35

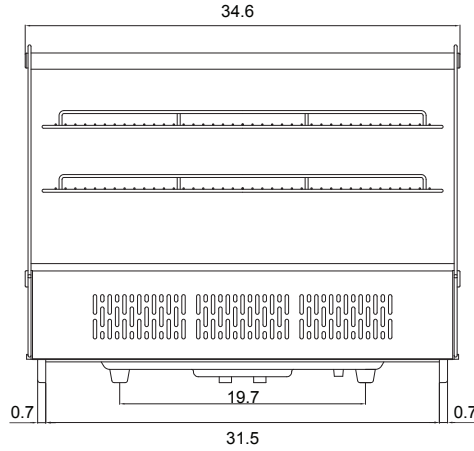

C-70CTS-48

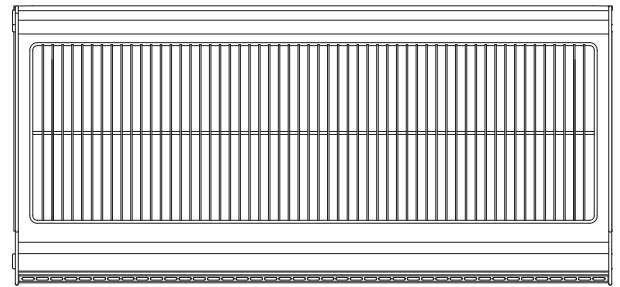
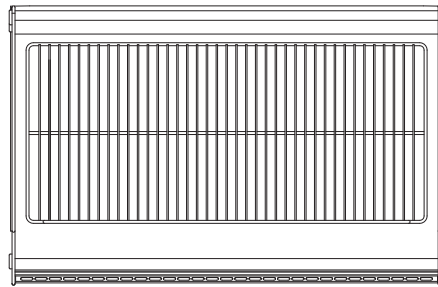
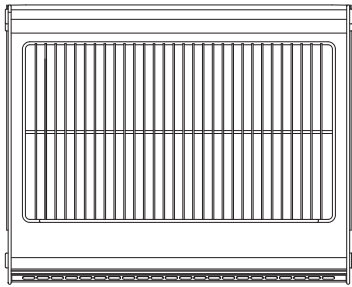
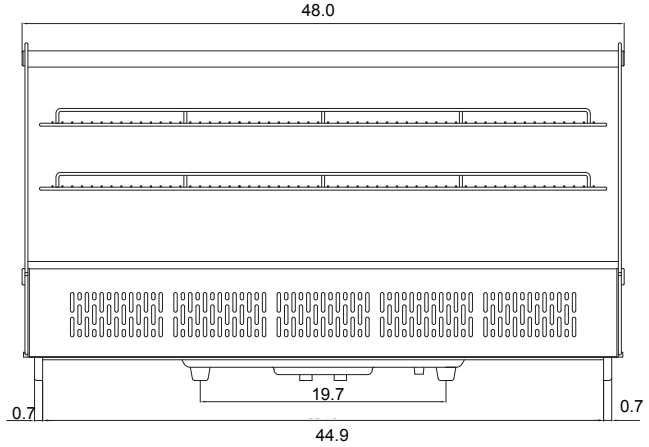

SIDE VIEW

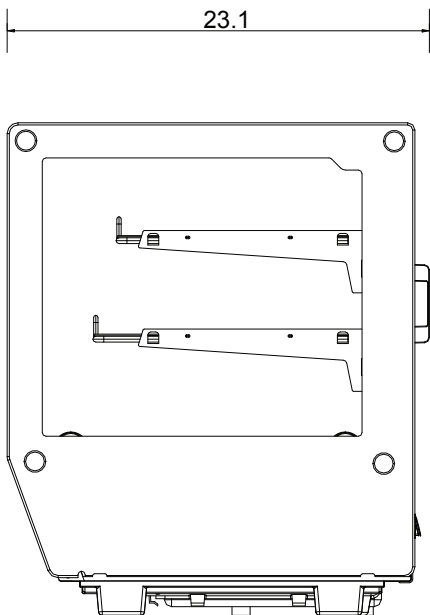

C-88CTS-60

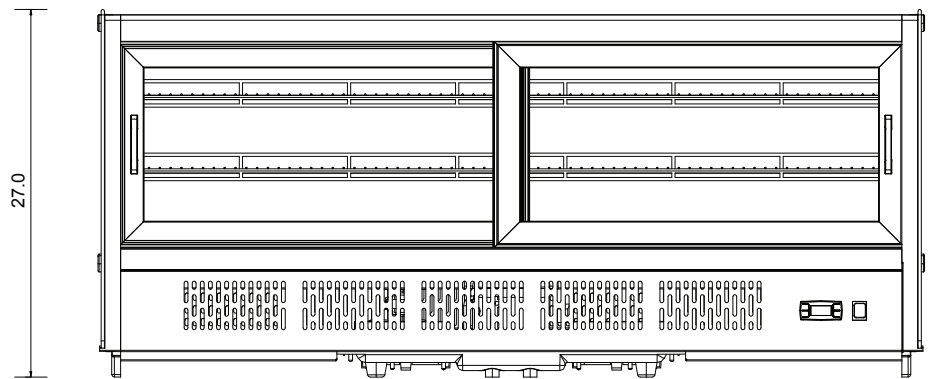

MIGALI® REMAINS AN AMERICAN FAMILY COMPANY SINCE 1955