

ANGELO PO – TBFXA610



OPEN STAND FOR OVENS FX61 - FX101

AISI 304 stainless steel structure with undershelf and height-adjustable feet. For a (18) 12"X20" Hotel Pan Capacity please add accessory TBFXA61V. Optional: KRTB610 wheels; KSTBFX space-saving tanks kit for detergent and brightener; KASX seismic feet kit, CPTX3 drawer for two tanks.

Net Dimensions WxDxH	34.96"x27.24"x26.9" (88.8x69.2x68.3 cm)
Shipping Dimensions WxDxH	35.5"x31.5"x33.5" (90x80x85 cm)

Call Angelo Po America customer care or technical service if there is any further clarification required.

ANGELO PO AMERICA - 2920 TURNPIKE DRIVE HATBORO, PA 19040 - 1-888-OVENS4

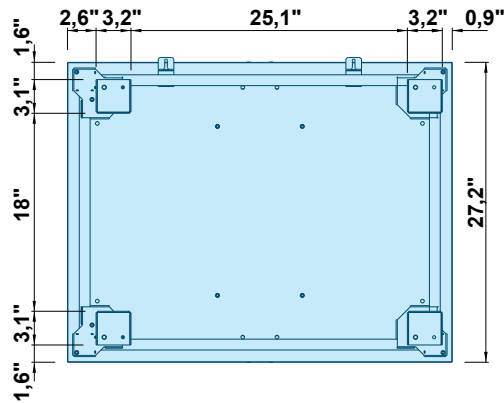
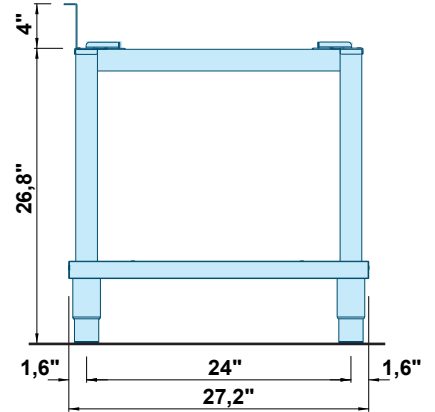
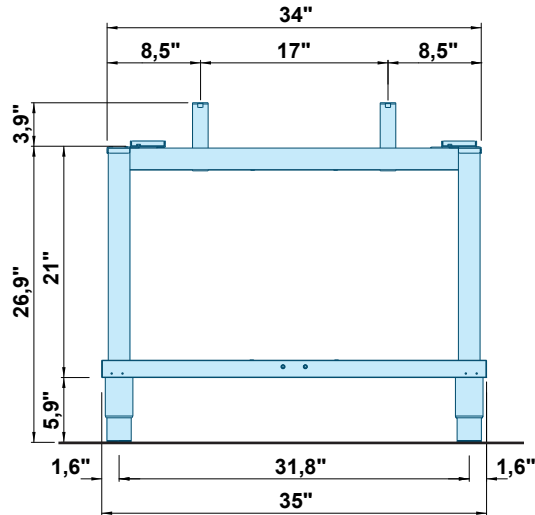

: YYhig\ ck b`UhiU`Yghdc]bh`7 Ub`VY`ck YfYX`tc` (ffi

Progetto - Lay Out - Projet - Entwurf - Proyecto	Area - Area - Area - Zone - Area	Posizione - Item - Position - Position - Posiccion
Offerta - Offer - Offre - Angebot - Oferta	Area - Area - Area - Zone - Area	Posizione - Item - Position - Position - Posiccion