

LEONARDO 370 EVO VCS TOP - 15"

Full-size, straight-feed slicer, for fresh meat and bolas



Leonardo 370 EVO VCS TOP

- 15" high-quality, heavy-duty straight-feed fresh meat slicers
- Specially designed double-feed carriage to support fresh meat
- Ideal for meat depts, butcheries and carnicerías. Perfect for bola (bistecs, arranchera and milanesa)
- The TOP version provides even higher durability in terms of reduced maintenance costs with:
 - all knobs, handles, dials and feet in aluminum
 - a fully sealed and waterproof IP 67 switch, with stainless steel on/off buttons
 - no volt release prevents inadvertent reactivation after a power outage
 - complete stainless steel drive shaft assembly

Features

Technical

- The special carriage allows you to slice any kind of raw meat
- The sharpener assembly is made entirely from aluminum, no plastic that may break with heavy use.
- The tie rod assembly and all screws are made of stainless steel for longer life.
- The slide shaft is made of ground, chromed steel for a smoother operation.
- The high-quality bushings and ball bearings are self-lubricating.
- The dial thickness control cam system allows for an always precise cut.

Safety

- A safety cover is placed under the motor and the electrical components.
- The hopper features an exclusive heavy duty plastic protection to keep operator's hand at a safe distance from the blade while operating slicer

Sanitary

- Easy to clean aluminum alloy construction does not crack or stain.
- The screws are stainless steel and resist wear and oxidation.
- The carriage and the center plate are quickly removable without tools.

Specifications

Operation:	Straight Feed.
Construction:	Polished, anodized aluminum alloy.
Knife:	15" (370 mm), one piece, chromium plated 100Cr6 forged carbon steel blade.
Sharpener:	Built-in, removable, two stone dual action.
Slice thickness:	Infinitely variable up to 13/16"
Motor:	1/2 Hp (410 W), belt driven, fan cooled.
Electrical:	120V AC, 60Hz, 3.10 Amp. (220V, 50Hz available on request).
Plug and Cord:	Attached, flexible, 3 wire SJT AWG 16, 6'4" long, NEMA 5-15 P
Controls:	ON/OFF stainless steel keypad, IP 67 waterproof protection. No voltage release.



Removable end weight pusher

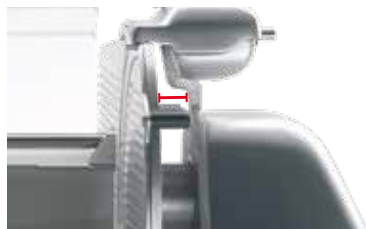

Increased gap between blade and machine body



Reduced gap between blade and end weight



Adjustable aluminum feet



Dual-stage cam allows precise thin and thick slicing



Stainless steel slice deflector

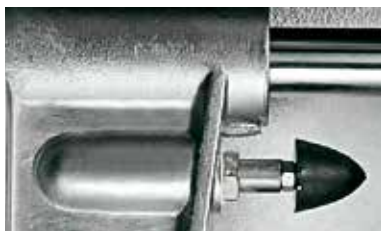

Carriage buffer



Built-in sharpener



Sealed electrical enclosure

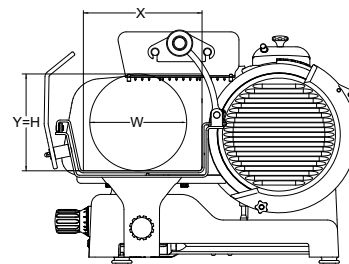
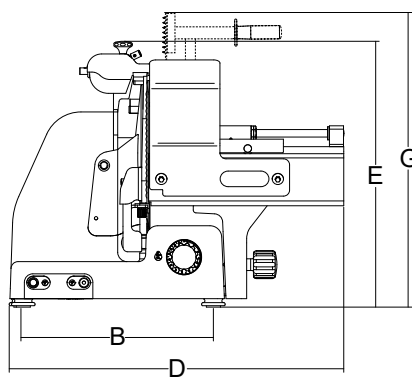
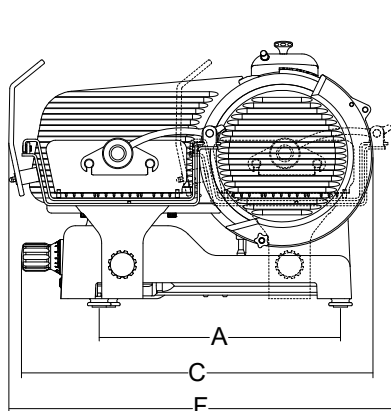

	Ø Blade	Motor	Cut thickness	Blade rpm	Carriage stroke	Hopper	A	B	C	D	E	F	G	X	Y	H	W	Net weight	Shipping	Gross weight	
	mm/inch	watt/Hp	inch.	rpm	inch.	inch.	inch.	inch.	inch.	inch.	inch.	inch.	inch.	inch.	inch.	inch.	inch.	lbs.	inch.	lbs.	
Leonardo 370 EVO VCS TOP	370/15"	410-0,55	1"	216	14 ^{9/16"}	16 ^{58/64"} x 11 ^{13/16"}	22 ^{14/64"}	16 ^{9/64"}	29 ^{9/64"}	28 ^{11/32"}	23 ^{3/8"}	33 ^{9/64"}	25 ^{13/64"}	11	39 ^{64"}	10 ^{5/32"}	10 ^{5/32"}	10 ^{5/32"}	124	33" x 34" x 33"	200