



Project Name: _____

Location: _____

Item #: _____

Qty: _____

Grista Pizza Prep Table, 2 Door - 71"

GRPZ-2D



The Grista 2 Door Refrigerated Pizza Prep Table combines refrigerated storage with a convenient work surface to help streamline the preparation process in pizzerias, restaurants and other foodservice establishments. It allows your kitchen staff to quickly and efficiently assemble pizzas with all the necessary ingredients within arm's reach. This pizza prep table has two self-closing doors and is made of a 430 stainless steel exterior and painted aluminum interior to meet the demands of your commercial kitchen.

FEATURES AND CONSTRUCTION

- 2 self-closing doors with recessed handles
- 17 cubic feet of storage
- 430 stainless steel exterior and painted aluminum interior
- 2 adjustable plastic coated steel shelves
- Hinged insulated lid
- 19" deep by 3/4" thick polyethylene cutting board
- Precise digital temperature controller with LED display
- Temperature range of 33°F to 41°F ensures ingredients remain fresh and safe for consumption
- Side mount self-contained refrigeration
- (4) 4" casters (2 locking and 2 non-locking)

ELECTRIC

115V / 60Hz / 1Ph
Cord Length (Inches): 98.40"
Plug Type: NEMA-5-15P
Cord set included

NEMA 5-15P



3RD PARTY APPROVALS

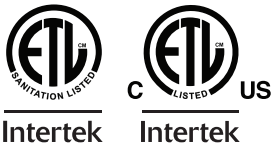

NOMINAL STORAGE CAPACITY

Cubic Feet: 19.3 cu. ft.

TEMPERATURE

Holding Temperature (Fahrenheit): 33° - 40°

These models are designed to operate in an environment where temperature and humidity do not exceed 75°F (24°C) and 55% relative humidity

WARRANTY (USA / CANADA)

2 Year Warranty on Parts & Labor, 5 Years on Compressor
Contact Admiral Craft Equipment for details at 1-877-672-7740





Grista Pizza Prep Table, 2 Door - 71"

GRPZ-2D

FRONT

SIDE

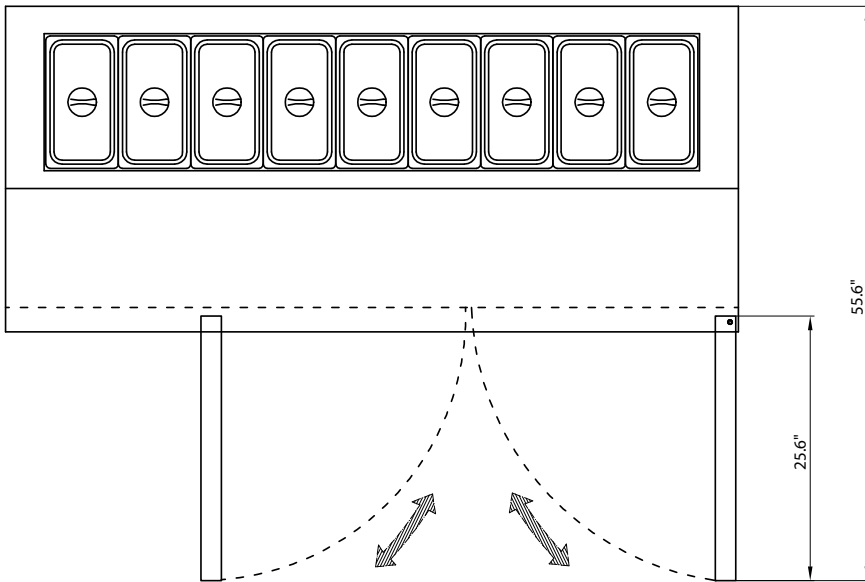
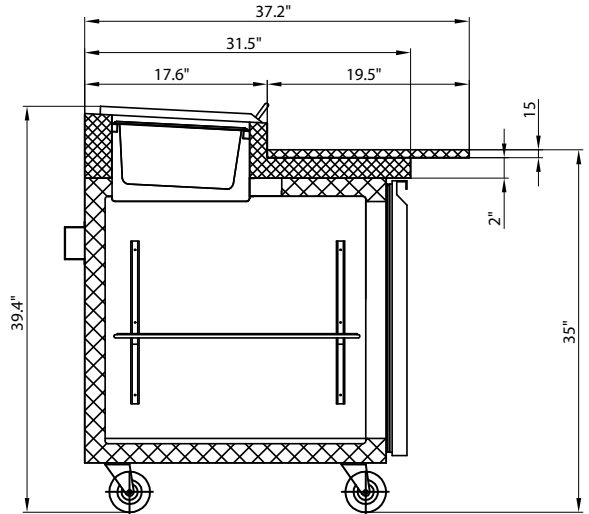
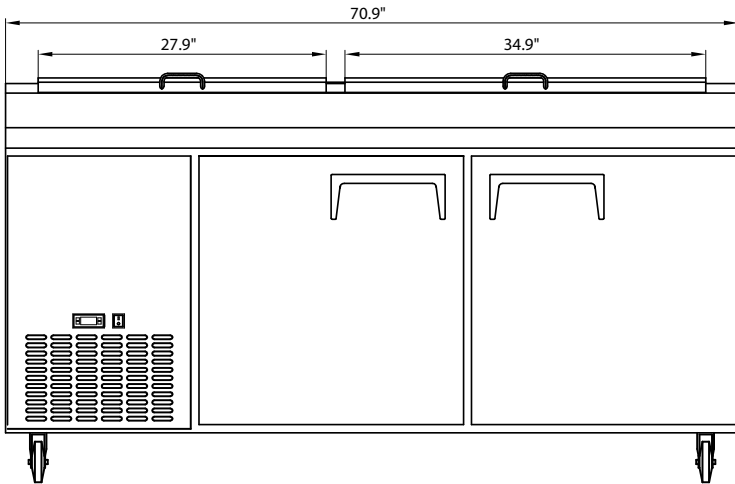

TOP

Pizza Prep Tables

Doors	Shelves	Amps	HP	Refrigerant	Capacity	Dimensions	Item Weight lbs	Shipping Weight lbs
2	2	4.8A	0.75	R290	19.3 cu. ft.	70.9" x 31.5" x 39.4"	341.0	475.0

Due to periodic changes in designs, methods, procedures, policies and regulations, the specifications contained in this document are subject to change without notice. While we exercise good faith efforts to provide information that is accurate, we are not responsible for errors or omissions in information provided or conclusions reached as a result of using the specifications. By using the information provided, the user assumes all risks in connection with such use.