



# BEVERAGE-AIR®

Project: _____	AIA#
Item: _____	
Location: _____	SIS#
Approved: _____	

**RB35HC BOTTOM MOUNT: VISTA® SERIES**

## VISTA® BOTTOM MOUNT REACH-IN REFRIGERATOR

**MODEL:  
RB35HC-1S**

RB35HC Solid Door Reach-In Refrigerator  
Hydrocarbon Series



**7 Year Parts/Labor Warranty  
7 Year Compressor Warranty**

### CABINET CONSTRUCTION

- Stainless steel front and doors, gray painted sides
- Gray painted aluminum interior
- Full electronic control
- LED lighting
- Door locks
- Self-closing doors with 120° stay-open feature, on spring-loaded hinges
- One-piece grille allow easy removal/installation for preventative maintenance
- Six (6) heavy duty epoxy coated wire shelves standard
- 6" Casters standard with (2) brakes

### OPTIONS & ACCESSORIES

- Stainless steel universal tray slides (AC)
- Epoxy shelves
- Shelf clips
- 3" Casters or 6" legs
- 6" Flanged/seismic feet
- Remote option\* (see note on back page)

### REFRIGERATION SYSTEM

- Uses environmentally friendly, energy efficient R290 refrigerant, and meets all regulatory requirements for CARB, SNAP, DOE & more
- Adaptive defrost
- Epoxy coated evaporator coil
- Maintains product temperatures between 36°-38°F



 Please verify qualifying units by visiting:  
[www.energystar.gov/cfs](http://www.energystar.gov/cfs)

3779 Champion Blvd., Winston-Salem, NC 27105  
1-888-845-9800 Fax: 1-336-245-6453  
Beverage-Air.com Sales@bevair.com



# BEVERAGE-AIR

MODEL	RB35HC-1S
<b>EXTERNAL DIMENSIONAL DATA</b>	
Width Overall	39 1/2"
Depth Overall with Handle	33 3/4"
Height Overall	84 1/8"
Number of Doors	2
Depth with Door Open 90°	49 3/4"
Door Openings (in)	16 1/2" x 52 1/2"
<b>INTERNAL DIMENSIONAL DATA</b>	
NET Capacity (cubic ft.)	35.082
Internal Width Overall (in)	36 1/2"
Internal Depth Overall (in)	28 1/2"
Internal Height Overall (in)	61 3/4"
Internal Height Useable (in)	55"
Number of Shelves	6
<b>ELECTRICAL DATA</b>	
Full Load Amperes	3.9
Voltage	115/60/1
Nema Plug (8' cord)	5-15P
<b>REFRIGERATION DATA</b>	
Horsepower	1/3
Capacity (BTU/Hr)	2291
Heat Rejection (BTU/Hr)	3437
Charge (lbs/grams/ounce)	0.243 / 110 / 3.9
<b>SHIPPING DATA</b>	
Gross Weight (crated lbs)	428 lbs
Height - Crated	87"
Width - Crated	49"
Depth - Crated	36"

\*NOTE: Remote units are field wired and come with 6" legs.  
Refrigerant must be specified at time of order.

We reserve the right to change specifications and product design without notice. Such revisions do not entitle the buyer to corresponding changes, improvements, additions or replacements for previously purchased equipment. Dimensional tolerances +/- 1/4". Metric dimensions (MM).

## VISTA® Bottom Mount Reach-In Refrigerator Model: RB35HC-1S

### Model Views

Required Clearance: Rear 3" & Bottom 3"

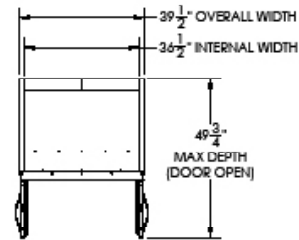

### PLAN VIEW

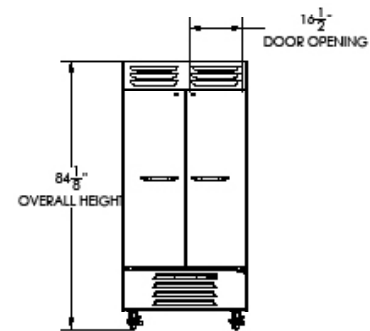

### ELEVATION VIEW

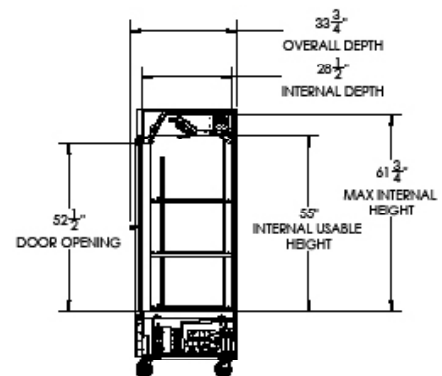

### SIDE VIEW

### ELECTRICAL CONNECTION



115/60/1  
NEMA 5-15P

Unit pre-wired at factory and include 8' long cord and plug set.

