



C-U27F-D-HC



C-U48F-D-HC



C-U60F-D-HC

UNDER-COUNTER/WORK TOP FREEZERS WITH DRAWERS

- Beautiful ergonomic construction & rounded corners
- Digital temperature controller and read-out
- All stainless steel exterior and interior
- Forced air refrigeration system
- Recessed drawer handles
- Pre-installed casters and shelving
- Drawers with stainless steel drawer slides and nylon wheels
- 90 degree hold open door feature for loading products
- Optional Accessory: Backsplash for Work-Tops for in-the-field installment**, Taller 6" casters available***
- All Natural R290 Hydrocarbon Refrigerant
- US Department of Energy Certified
- Migali® Protection Plan: 2 Year Parts & Labor Warranty, 5 Years Compressor Warranty

MODEL	DAWERS	CAPACITY CU/FT	SHELVES	H/P	AMPS	VOLTAGE	ENERGY CONSUMPTION KWH/24 HR	PLUG TYPE	TEMP RANGE	EXTERIOR DIMENSIONS W X D X H*	INTERIOR DIMENSIONS W X D X H	PACKAGED DIMENSIONS W X D X H	WEIGHT	PACKAGED WEIGHT
C-U27F-D-HC	2	6.5	2	1/5	1.8	115/60/1	2.7	Nema 5-15P	-7° F (-) 3° F	27.5 x 30 x 34.1	23.9 x 23.6 x 26.7	29 x 32 x 39	146 lbs.	179 lbs.
C-U48F-D-HC	4	12	4	1/4+	2.6	115/60/1	4.1	Nema 5-15P	-7° F (-) 3° F	48.25 x 30 x 34.1	44.7 x 23.6 x 26.7	50 x 32 x 39	203 lbs.	245 lbs.
C-U60F-D-HC	4	17.9	4	1/4+	2.6	115/60/1	4.9	Nema 5-15P	-7° F (-) 3° F	60.25 x 30 x 34.1	56.7 x 23.6 x 26.7	63 x 32 x 39	230 lbs.	276 lbs.

* Total height includes casters

**Accessories: Stainless Steel Back Splash - BS27 - 27" wide / BS48 - 48" wide / BS60 - 60" wide

*** Optional 6" casters available - Part # 1759-208

FOR COMMERCIAL USE ONLY

NOTE: MIGALI® RESERVES THE RIGHT TO CHANGE SPECIFICATIONS WITHOUT NOTICE



DIMENSIONAL DRAWINGS

C-U27F-D-HC

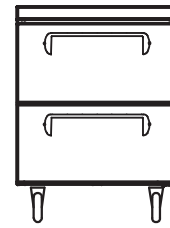

C-U27F-D-HC TOP VIEW

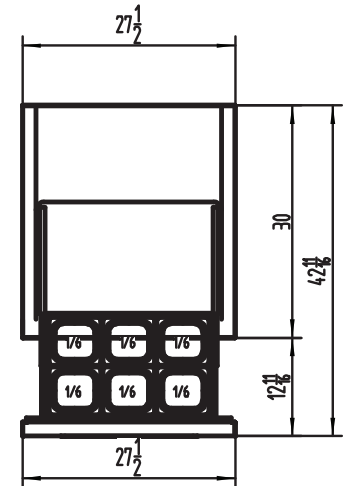

C-U48F-D-HC

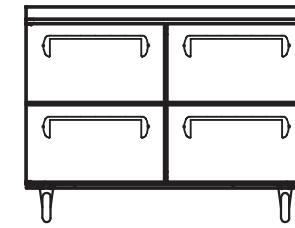

C-U48F-D-HC TOP VIEW

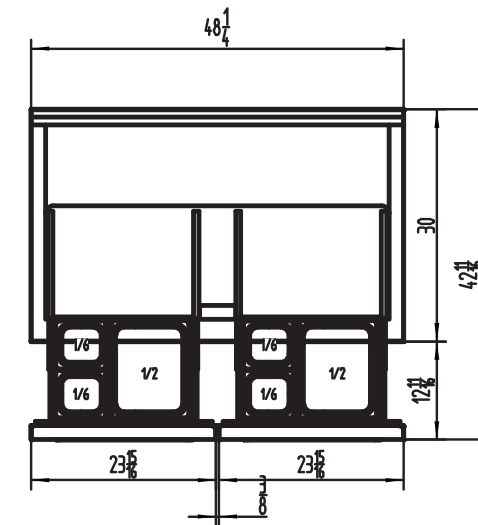

C-U60F-D-HC

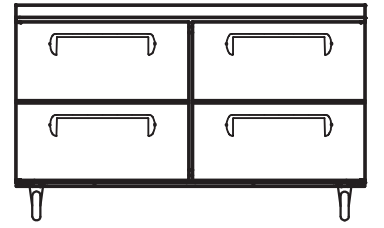

C-U60F-D-HC TOP VIEW

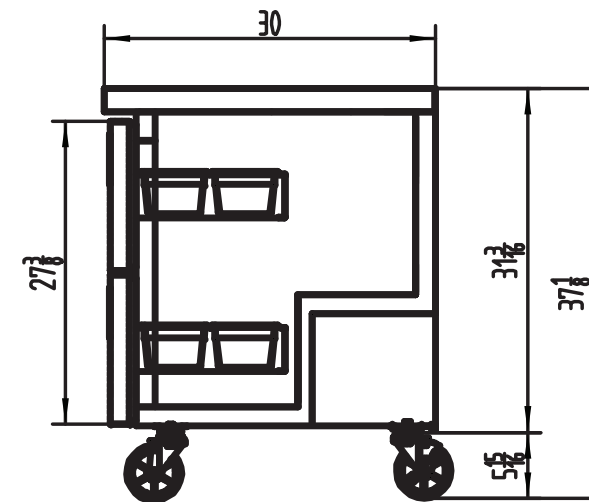
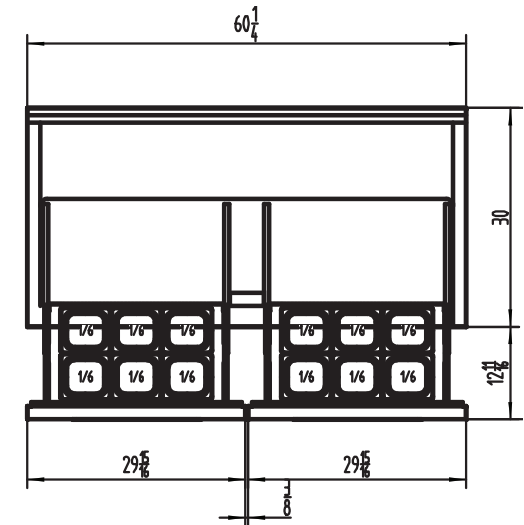

SIDE VIEW (2,4) DRAWER MODELS