

Item # _____

Qty # _____

Model # _____

Project # _____



DUKERS

Quality Commercial Refrigeration



GAS RANGE

DCR36-4B12GM

36" Combination - 4 Burner & 12" Griddle Top



Knobs

Cooking Surface



PRODUCT DESCRIPTION

- ✦ Stainless steel exterior including front, back sides, kick plate, back guard and over shelf
- 🍳 Heavy duty 12" X 12" removable, cast iron top grates
- 🔥 Oven temperature range between 175°F to 500°F
- 🔌 3/4" NPT rear gas connection and regulator standard.
- 🍽️ Two(2) chrome oven rack per oven standard, multiple position oven rack guides
- 🍳 Enamel interior oven for easy cleaning.
- 🛞 6" casters with lock for easy mobility.



HIGH QUALITY STAINLESS STEEL & ROBUST DESIGN

GAS RANGE MODEL	DIMENSION		
	Width	Depth	Height
DCR36-4B12GM	36 in	31 1/2 in	56 in



Los Angeles | San Francisco | Dallas
Houston | Florida | Chicago | New Jersey

📞 1-800-931-8628

@ info@dukersusa.com

www.DukersUSA.com

DETAILS & SPECIFICATIONS

DCR36-4B12GM

Front View

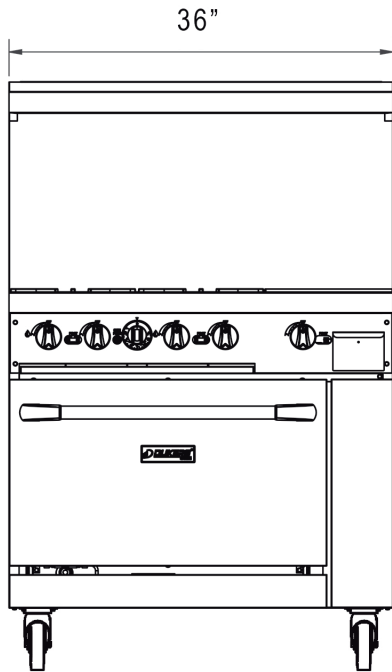

Side View

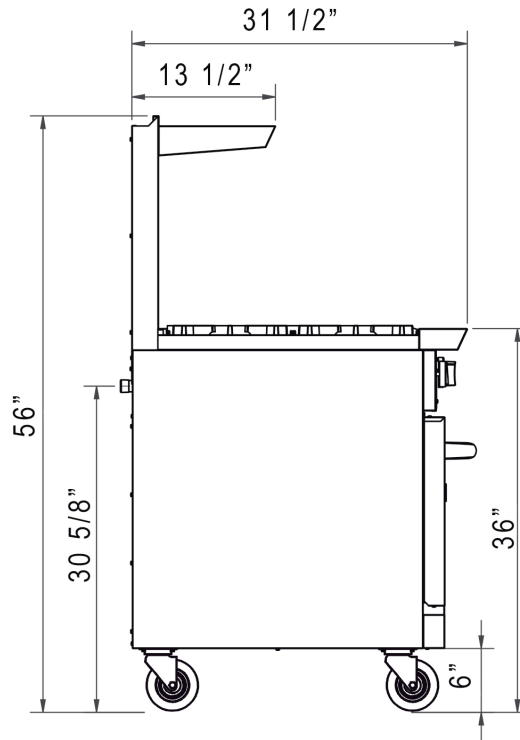

Top View

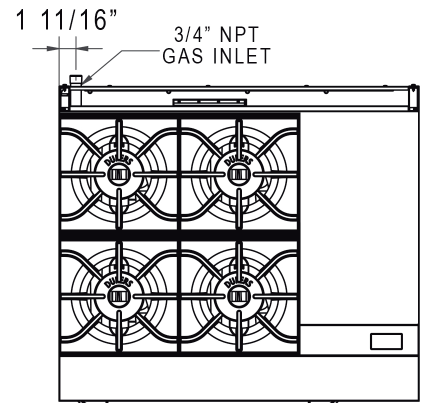

SANITATION



US

Conforms to NSF/ANSI7 (ETL)



Product Specifications

WORKING AREA 24" x 24" & 12x20"

GAS TYPE LPG/NG

	LPG			NG		
	HOT PLATE	GRIDDLE	OVEN	HOT PLATE	GRIDDLE	OVEN
BURNERS	4	1	1	4	1	1
SINGLE OUTPUT BTU	30000 BTU	28000 BTU	35000 BTU	33000 BTU	28000 BTU	35000 BTU
NOZZLE #	52	53	49	41	43	38
TOTAL OUTPUT BTU	183000 BTU			195000 BTU		
GAS PRESSURE	10			5		

Model	Packaging Dimensions (inches)			Net Weight (lbs)	Ship Weight (lbs)	Container Capacity 40'HQ
	W	D	H			
DCR36-4B12GM	38 1/10"	36 4/5"	38 1/5"	375.76	461.56	52



Los Angeles | San Francisco | Dallas
Houston | Florida | Chicago | New Jersey

1-800-931-8628

@ info@dukersusa.com

www.DukersUSA.com