

Project: \_\_\_\_\_  
 Location: \_\_\_\_\_  
 Item #: \_\_\_\_\_ Quantity: \_\_\_\_\_  
 Model #: \_\_\_\_\_

**MODEL: IRT-UC72P** **REACH-IN: Slimline Reach-in Refrigerators (Glass Door)**



**General Strengths**

- ✓ **Sanitation.** The inside of the table is constructed with rounded corners (large radius for easy cleaning). Possibility to quickly remove shelves and runners for interior cleaning. Each table has a drain at the bottom of the unit. When cleaning the unit, make sure the drain hose is directed to a floor drain.
- ✓ **Doors.** Self-closing door system with permanent pressure. Stay open feature included when door remains open after 95 degrees. All doors include triple chamber door gaskets, easy to remove and snap in. Doors are field reversible.
- ✓ **Control systems.** Higher precision in managing temperature settings. Greater ability for the adjustment of temperatures ranges as per the end user's requirement.
- ✓ **100% Tested.** All condenser units are tested 100%, in helium chambers to refrigerant leak detections.
- ✓ **Certified.** Audited and Certified by **INTERTEK** for compliance with UL 471 and NSF 7. EQA audited and certified by internationally recognized firm. ISO 9001:2015 (Quality); ISO 14001:2015 (Environmental); ISO 45001:2018 (Prevention and Worker Safety)

Revision:01 Date: 12/05/2022 IRT-UC72P

MODELS	Dimensions (inches) (mm)			Doors	Shelves	Ref.	Ref.Weight (Lbs.) (gr.)	Temperatur e Range (°F) (°C)	Cond. Unit (H.P)	Capacity (Cu.Ft.) (L)	Case Amps 115V	Net weight (Lbs.) (Kg.)
	W	D	H									
IRT-UC72P	72-5/8 (1844)	30-1/8 (765)	46-1/4 (1175)	3/18	6/6	R290	0,25 (115)	35 °F/41 °F (+2°C/+5°C)	1/3	21 (594)	4,6	500 (227)

ETL LISTED TO UL471 STANDARD AND SANITATION CLASSIFIED TO NSF7 – WE RESERVE THE RIGHT TO CHANGE SPECIFICATIONS WITHOUT PRIOR NOTICE



**INFRICO-North America Corporate División**  
 1409NW 84<sup>th</sup> Avenue, Doral FL 33126  
 (305) 777 9599 ext.700 / f (305) 777 9598  
 Toll Free 855-340-4637

[www.infrico.us](http://www.infrico.us)  
[sales@infrico.com](mailto:sales@infrico.com)  
[service@infrico.com](mailto:service@infrico.com)

**MODEL: IRT-UC72P**

**REACH-IN:  
 Slimline Reach-in Refrigerators (Glass Door)**

**STANDARD FEATURES**

➤ **Exterior**

- AISI 430 Stainless Steel,
- AISI 304 Stainless Top.

➤ **Interior**

- AISI 304 Stainless Steel,

➤ **Doors**

- Polyurethane insulated door,
- Self – closing door with stay open feature,
- Stainless Steel heavy-duty hinges,
- Triple chamber snap in door gaskets for easy removal and cleaning,
- Field reversible door, parts not included,
- Full-height door opening: 19-5/8" x 21-7/8" (500x555 mm)

**OPTIONAL FEATURES**

- Set of 2" diameter casters, with lock provided on front set,
- Electrical connection is: 220-230 V / 1ph / 50 Hz (plug type varies),
- Drawer kit,
- Flat kit,
- Flat lid,
- Single Overshelf,
- Double Overshelf.

➤ **Insulation**

- Polyurethane with high density 40kg/m<sup>3</sup>, CFS free, zero ODP and low GWP.
- Low GWP & Zero ODP effect.

➤ **Salad Top**

- Stainless Steel insulated lid,
- Top includes 1/6 size polycarbonate food pans, (18) pans,
- Pan divider bars included for varying size pan configurations,
- Removable sanitary polyethylene cutting board included.

➤ **Shelving**

- (2) Two plastic coated wire shelves,
- Set of Stainless Steel shelf brackets,
- Easy remove for cleaning,
- Dimensions WxD: 21" x 17" (533x432 mm), 22-1/4" x 17" (565x432 mm)

➤ **Casters**

- 4" diameter casters,
- Locks provided on front set.

➤ **Refrigeration**

- Temperature regulated by thermostatic control,
- Stainless Steel evaporative pan,
- Evaporator coil coated with anti-corrosion material 100% polyester,
- Forced air refrigeration system,
- Refrigeration capacity: 1583 Btu/h (14°F) / 467 W (-10°C).

➤ **Electrical**

- Cord and NEMA 5-15P plug,
- Electrical connection is 115 V / 1ph / 60 Hz.



➤ **ETL Listed to UL471 Standard and Sanitation classified to NSF7.**

ETL LISTED TO UL471 STANDARD AND SANITATION CLASSIFIED TO NSF7 – WE RESERVE THE RIGHT TO CHANGE SPECIFICATIONS WITHOUT PRIOR NOTICE



Project: \_\_\_\_\_  
 Location: \_\_\_\_\_  
 Item #: \_\_\_\_\_ Quantity: \_\_\_\_\_  
 Model #: \_\_\_\_\_

**MODEL: IRT-UC72P** **REACH-IN:**  
**Slimline Reach-in Refrigerators (Glass Door)**

**ELEVATION** **RIGHT VIEW** **PLAN VIEW**

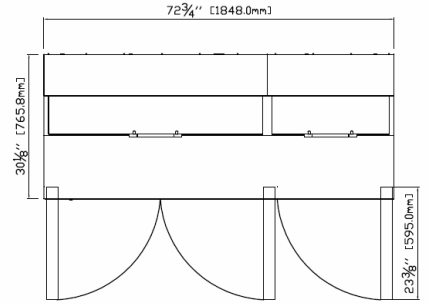
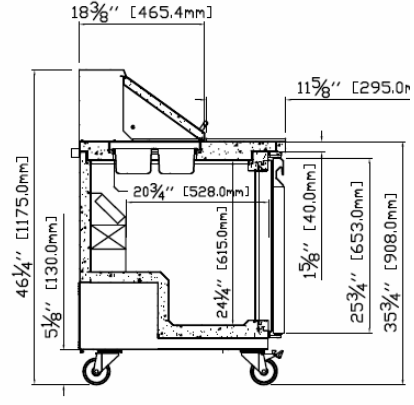
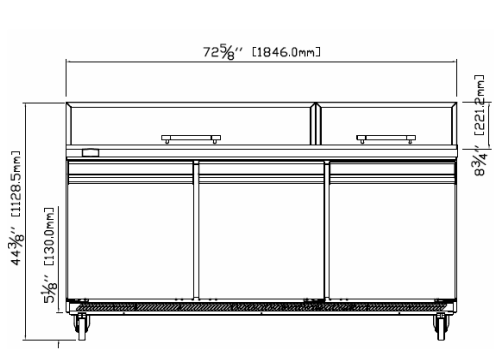

ETL LISTED TO UL471 STANDARD AND SANITATION CLASSIFIED TO NSF7 – WE RESERVE THE RIGHT TO CHANGE SPECIFICATIONS WITHOUT PRIOR NOTICE

**INFRICO-North America Corporate División**  
 1409NW 84<sup>th</sup> Avenue, Doral FL 33126  
 (305) 777 9599 ext.700 / f (305) 777 9598  
 Toll Free 855-340-4637

[www.infrico.us](http://www.infrico.us)  
[sales@infrico.com](mailto:sales@infrico.com)  
[service@infrico.com](mailto:service@infrico.com)



Revision: 01 Date: 12/05/2022 IRT-UC72P