



BEVERAGE-AIR

Project: _____	AIA#
Item: _____	
Location: _____	SIS#
Approved: _____	

MMR35HC GLASS DOOR MERCHANDISER SERIES

MARKETMAX REFRIGERATOR

MMR35HC Black Hinged Double Glass Door Hydrocarbon Series

MODEL:
MMR35HC-1-B



7 Year Parts/Labor Warranty
7 Year Compressor Warranty

CABINET CONSTRUCTION

- Exterior features durable black painted steel
- Heavy-duty interior construction includes white coated steel walls
- Modern one-piece grille
- Full electronic control
- Refrigerators have double pane lowE argon filled glass doors
- Self-closing doors with 120° stay-open feature
- Snap-in gaskets, easy to remove for cleaning or replacement
- Field reversible doors (hinge kit not included)
- LED lighting
- Brightly lit sign panel
- Ten (10) heavy-duty epoxy coated wire shelves
- Four (4) shelf clips included per shelf
- Self-contained bottom mount refrigeration system
- Leveling feet standard

OPTIONS & ACCESSORIES

- Stainless steel or white exterior
- Stainless steel or black interior
- Shelves black or white
- Shelf clips
- Flow track
- Gravity-Flo track
- Price tag molding
- Electronic lock models (swing doors only)
- 3" - 6" Casters or
- 6" Seismic/flanged legs
- Door locks
- Custom signage & decals
- Remote option* (see note on back on page)

REFRIGERATION SYSTEM

- Uses environmentally friendly, energy efficient R290, and meets all regulatory requirements for CARB, SNAP, DOE & more
- Non-electric defrost with hot gas condensate evaporation
- Epoxy coated evaporator coil
- Maintains product temperatures between 36° - 38°F



Please verify qualifying units by visiting:
www.energystar.gov/cfs

3779 Champion Blvd., Winston-Salem, NC 27105
1-888-845-9800 Fax: 1-336-245-6453
Beverage-Air.com Sales@bevair.com



BEVERAGE-AIR

MODEL	MMR35HC-1-B
EXTERNAL DIMENSIONAL DATA	
Width Overall	39 1/2"
Depth Overall with Handle	33 1/2"
Height Overall	78 1/8"
Number of Doors	2
Depth with Door Open 90°	49 3/4"
Door Openings (in)	16 1/2" x 52 1/2"
INTERNAL DIMENSIONAL DATA	
NET Capacity (cubic ft.)	35.082
Internal Width Overall (in)	36 1/2"
Internal Depth Overall (in)	28 1/2"
Internal Height Overall (in)	61 3/4"
Internal Height Useable (in)	55"
Number of Shelves	10
ELECTRICAL DATA	
Full Load Amperes 115/60/1	3.9
REFRIGERATION DATA	
Horsepower	1/3
Capacity (BTU/Hr)	2291
Heat Rejection (BTU/Hr)	3437
Charge (lbs/grams/ounces)	0.2425 / 110 / 3.9
SHIPPING DATA	
Gross Weight - Crated	506 lbs
Height - Crated	84"
Width - Crated	46"
Depth - Crated	36"

*NOTE: Remote units are field wired and come with 6" legs.
Refrigerant must be specified at time of order.

We reserve the right to change specifications and product design without notice. Such revisions do not entitle the buyer to corresponding changes, improvements, additions or replacements for previously purchased equipment. Dimensional tolerances +/- 1/4". Metric dimensions (MM).

Glass Door Merchandiser- Hinged Door Model: MMR35HC-1-B

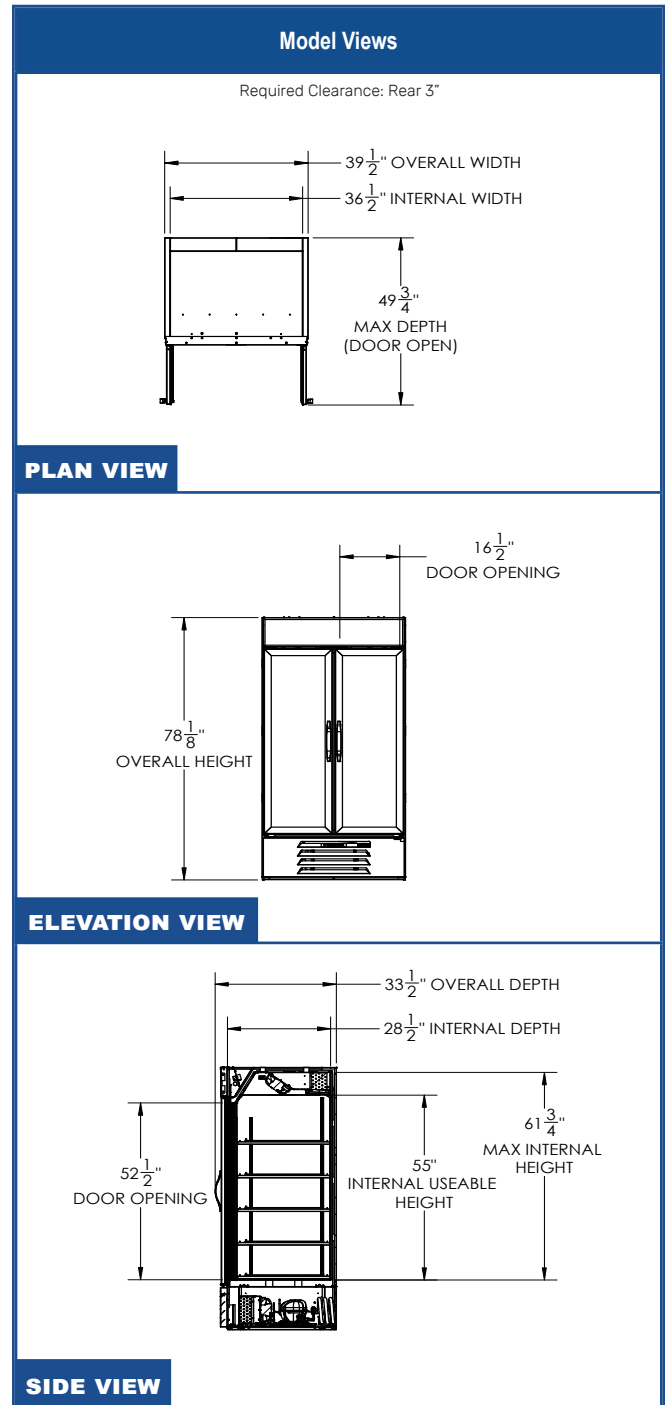

ELECTRICAL CONNECTION



115/60/1
NEMA 5-15P

Unit pre-wired at factory and include 8' long cord and plug set.

