



## ***Refrigerated Showcases***

Models RS-CN-0440, 0530, 0700, 1050, 0440-B, 0530-B, 0700-B, 1050-B

Items 48479, 43459, 41469, 43460, 48480, 48265, 48266, 48269

## ***Instruction Manual***



*Revised - 12/06/2024*

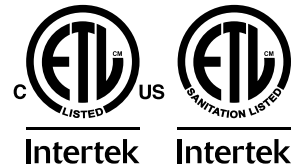

Toll Free: 1-800-465-0234  
Fax: 905-607-0234  
Email: [service@omcan.com](mailto:service@omcan.com)  
[www.omcan.com](http://www.omcan.com)



# ***Table of Contents***

Model RS-CN-0440 / Model RS-CN-0530 / Model RS-CN-0700  
Model RS-CN-1050 / Model RS-CN-0440-B / Model RS-CN-0530-B  
Model RS-CN-0700-B / Model RS-CN-1050-B

---

<b>Section</b>	<b>Page</b>
Disclaimer -----	3
General Information -----	4 - 5
Safety and Warranty -----	5 - 7
Technical Specifications -----	8 - 9
Operation -----	9 - 10
Maintenance -----	11
Troubleshooting -----	11 - 12
Parts Breakdown -----	13 - 36
Electrical Schematics -----	37 - 40
Notes -----	41 - 42
Warranty Registration -----	43

## ***Disclaimer***

---

*OMCAN IS NOT RESPONSIBLE FOR ANY DAMAGES  
DUE TO WATER LEAKS. WARRANTY FOR WATER  
LEAKS IS VOID IF THE AMBIENT ROOM TEMPERATURE  
EXCEEDS 75°F AND 55% RELATIVE HUMIDITY, AND THE  
APPLIANCE DRAIN IS NOT CONNECTED DIRECTLY TO  
A FLOOR DRAIN.*

---

*OMCAN N'EST PAS RESPONSABLE DES DOMMAGES  
DUS AUX FUITES D'EAU. LA GARANTIE POUR LES  
FUITES D'EAU EST ANNULÉE SI LA TEMPÉRATURE  
AMBIANTE DE LA PIÈCE DÉPASSE 75°F ET 55%  
D'HUMIDITÉ RELATIVE, ET SI LE DRAIN DE L'APPAREIL  
N'EST PAS RACCORDÉ DIRECTEMENT À UN DRAIN DE  
PLANCHER.*

---

*OMCAN NO SE HACE RESPONSABLE DE LOS DAÑOS  
CAUSADOS POR FUGAS DE AGUA. LA GARANTÍA  
POR FUGAS DE AGUA QUEDA ANULADA SI LA  
TEMPERATURA AMBIENTE SUPERA LOS 75°F Y EL  
55% DE HUMEDAD RELATIVA, Y EL DESAGÜE DEL  
APARATO NO ESTÁ CONECTADO DIRECTAMENTE A UN  
DESAGÜE DE PISO.*

## ***General Information***

---

**Omcan Manufacturing and Distributing Company Inc., Food Machinery of America, Inc. dba Omcan and Omcan Inc. are not responsible for any harm or injury caused due to any person's improper or negligent use of this equipment. The product shall only be operated by someone over the age of 18, of sound mind, and not under the influence of any drugs or alcohol, who has been trained in the correct operation of this machine, and is wearing authorized, proper safety clothing. Any modification to the machine voids any warranty, and may cause harm to individuals using the machine or in the vicinity of the machine while in operation.**

### **CHECK PACKAGE UPON ARRIVAL**

Upon receipt of an Omcan shipment please inspect for external damage. If no damage is evident on the external packaging, open carton to ensure all ordered items are within the box, and there is no concealed damage to the machine. If the package has suffered rough handling, bumps or damage (visible or concealed), please note it on the bill of lading before accepting the delivery and contact Omcan within 24 hours, so we may initiate a claim with the carrier. A detailed report on the extent of the damage caused to the machine must be filled out within three days, from the delivery date shown in the shipping documents. Omcan has no recourse for damaged products that were shipped collect or third party.

**Before operating any equipment, always read and familiarize yourself with all operation and safety instructions.**

**Omcan would like to thank you for purchasing this machine. It's of the utmost importance to save these instructions for future reference. Also save the original box and packaging for shipping the equipment if servicing or returning of the machine is required.**

---

**Omcan Fabrication et distribution Compagnie Limité et Food Machinery d'Amérique, dba Omcan et Omcan Inc. ne sont pas responsables de tout dommage ou blessure causé du fait que toute personne ait utilisé cet équipement de façon irrégulière. Le produit ne doit être exploité que par quelqu'un de plus de 18 ans, sain d'esprit, et pas sous l'influence d'une drogue ou d'alcool, qui a été formé pour utiliser cette machine correctement, et est vêtu de vêtements de sécurité appropriés. Toute modification de la machine annule toute garantie, et peut causer un préjudice à des personnes utilisant la machine ou des personnes à proximité de la machine pendant son fonctionnement.**

### **VÉRIFIEZ LE COLIS DÈS RÉCEPTION**

Dès réception d'une expédition d'Omcan veuillez inspecter pour dommages externes. Si aucun dommage n'est visible sur l'emballage externe, ouvrez le carton afin de s'assurer que tous les éléments commandés sont dans la boîte, et il n'y a aucun dommage dissimulé à la machine. Si le colis n'a subi aucune mauvaises manipulations, de bosses ou de dommages (visible ou cachée), notez-le sur le bond de livraison avant d'accepter la livraison et contactez Omcan dans les 24 heures qui suivent, pour que nous puissions engager une réclamation auprès du transporteur. Un rapport détaillé sur l'étendue des dommages causés à la machine doit être rempli dans un délai de trois jours, à compter de la date de livraison indiquée dans les documents d'expédition. Omcan n'a aucun droit de recours pour les produits endommagés qui ont été expédiés ou cueillis par un tiers transporteur.

**Avant d'utiliser n'importe quel équipement, toujours lire et vous familiariser avec toutes les opérations et les**



## General Information

consignes de sécurité.

Omcan voudrais vous remercier d'avoir choisi cette machine. Il est primordial de conserver ces instructions pour une référence ultérieure. Également conservez la boîte originale et l'emballage pour l'expédition de l'équipement si l'entretien ou le retour de la machine est nécessaire.

Omcan Empresa De Fabricacion Y Distribucion Inc. Y Maquinaria De Alimentos De America, Inc. dba Omcan y Omcan Inc. no son responsables de ningun daño o perjuicio causado por cualquier persona inadecuada o el uso descuidado de este equipo. El producto solo podra ser operado por una persona mayor de 18 años, en su sano juicio y no bajo alguna influencia de droga o alcohol, y que este ha sido entrenado en el correcto funcionamiento de esta máquina, y ésta usando ropa apropiada y autorizada. Cualquier modificación a la máquina anula la garantía y puede causar daños a las personas usando la máquina mientras esta en el funcionamiento.

### REVISE EL PAQUETE A SU LLEGADA

Tras la recepcion de un envio Omcan favor inspeccionar daños externos. Si no hay daños evidentes en el empaque exterior, Habra el carton para asegurarse que todos los articulos solicitados estén dentro de la caja y no encuentre daños ocultos en la máquina. Si el paquete ha sufrido un manejo de poco cuidado, golpes o daños (visible o oculto) por favor anote en la factura antes de aceptar la entrega y contacte Omcan dentro de las 24 horas, de modo que podamos iniciar una reclamación con la compañía. Un informe detallado sobre los daños causados a la máquina debe ser llenado en el plazo de tres días, desde la fecha de entrega que se muestra en los documentos de envío. Omcan no tiene ningun recurso por productos dañados que se enviaron a recoger por terceros.

Antes de utilizar cualquier equipo, siempre lea y familiarizarse con todas las instrucciones de funcionamiento y seguridad.

Omcan le gustaría darle las gracias por la compra de esta máquina. Es de la mayor importancia para salvar estas instrucciones para futuras consultas. Además, guarda la caja original y el embalaje para el envío del equipo si servicio técnico o devolución de la máquina que se requiere.

## Safety and Warranty

### HANDLING AND INSTALLATION

<b>Handle with care</b> Unplug from the wall socket before moving. Never tilt the refrigerator over 45 degrees during handling.	<b>Storage</b> Always store the refrigerator in a dry place.
--	---

# Safety and Warranty

<p><b>Sufficient space</b> To allow for proper air circulation and increased refrigeration capabilities, the refrigerator must have at least 4"/10cm of space between wall/ceiling and the machine.</p>	<p><b>Proper ventilation</b> Always place the refrigerator in an area with good ventilation. For first time use, set in location and wait at least 2 hours before plugging into wall socket.</p>
<p><b>Away from heat source</b> Never place the refrigerator near any type of heat source or in direct sunlight, as it reduces refrigeration capabilities.</p>	<p><b>No heavy load</b> Never put heavy items on top of the refrigerator.</p>
<p><b>No alterations/tampering</b> Never tamper with or make changes to the refrigerator. Changes and add-ons should not be installed to the inside or outside of the refrigerator.</p>	<p><b>Stable location</b> Unpack and place the refrigerator on flat, solid ground.</p>

## PREPARATION AND POWER SUPPLY

<p><b>Exclusive power outlet</b> Power supply should be 220V, single phase AC with exclusive single phase three pin outlet (250V/10A) and fuse (6A). The power outlet must be in close proximity to the ground.</p>	<p><b>No shared power outlets</b> Refrigerator cable should never share the power outlet with any other appliance, as cable will overheat and may result in a fire.</p>
<p><b>Protect cables</b> Extra caution should be used when handling cables, as broken or damaged cables can cause sparking and may result in a fire.</p>	<p><b>No water flushing</b> Never flush the refrigerator surface. This can cause leakage, which may result in electrical damage or fire.</p>
<p><b>Never store flammables and explosives</b> No explosives or flammables should be stored in, or in proximity to, the refrigerator, such as gasoline, alcohol, and adhesives.</p>	<p><b>No spray</b> Never spray flammables such as paint or coating near the refrigerator. This may cause fire or malfunction.</p>
<p><b>After power outage</b> After a power outage or the unplugging of the refrigerator, wait at least 5 minutes before plugging it back in.</p>	<p><b>No medicine</b> Medicine should not be stored inside of the refrigerator.</p>

**SUITABLE FOR HIGH TRAFFIC AREAS WHERE NOISE LEVELS ARE NOT A CONCERN.**

**OMCAN IS NOT RESPONSIBLE FOR DIMINISHED COOLING OR ANY DAMAGES DUE TO WATER LEAKS. WARRANTY FOR WATER LEAKS IS VOID IF THE AMBIENT ROOM TEMPERATURE EXCEEDS 75°F AND 55% RELATIVE HUMIDITY, AND THE APPLIANCE DRAIN IS NOT CONNECTED DIRECTLY TO A FLOOR DRAIN.**

**RESIDENTIAL USERS: vendor assumes no liability for parts or labor coverage for component failure or other**



## ***Safety and Warranty***

---

damages resulting from installation in non-commercial or residential applications. The right is reserved to deny shipment for residential usage; if this occurs, you will be notified as soon as possible.

### **1 YEAR PARTS AND LABOUR WARRANTY**

Within the warranty period, contact Omcan Inc. at 1-800-465-0234 to schedule an Omcan authorized service technician to repair the equipment locally.

Unauthorized maintenance will void the warranty. Warranty covers electrical and part failures not improper use.

Please see <https://omcan.com/disclaimer> for complete info.

### **WARNING:**

The packaging components are classified as normal solid urban waste and can therefore be disposed of without difficulty.

In any case, for suitable recycling, we suggest disposing of the products separately (differentiated waste) according to the current norms.

**DO NOT DISCARD ANY PACKAGING MATERIALS IN THE ENVIRONMENT!**

# Technical Specifications

## STEEL UNITS

Model	RS-CN-0440	RS-CN-0530	RS-CN-0700	RS-CN-1050
Item Number	48479	43459	41469	43460
Rated Input Power	1700 W		2550 W	2400 W
Capacity	440 L / 15.53 cu.ft.	530 L / 18.71 cu.ft.	700 L / 24.72 cu.ft.	1050 L / 37.08 cu.ft.
Electrical	110-120V / 60Hz / 1		220V / 60Hz / 1	
Shelf Load Capacity	55.1 lbs. / 25 kgs.		66.1 lbs. / 30 kgs.	110.2 lbs. / 50 kgs.
Temperature Range	2 - 10°C / 35.6 - 50°F			
Max Ambient Temp Rating	24°C / 75°F			
Refrigerant & Injection	R290			
Type of Climate	3			
Rated Current	16A		12.1A	11.5A
Weight	276.7 lbs. / 125.5 kgs.	335.1 lbs. / 152 kgs.	426.6 lbs. / 193.5 kgs.	565.5 lbs. / 256.5 kgs.
Packaging Weight	332.9 lbs. / 151 kgs.	388 lbs. / 176 kgs.	486.1 lbs. / 220.5 kgs.	652.6 lbs. / 296 kgs.
Dimensions	30" x 30.1" x 81.5" 762 x 765 x 2070mm	36" x 30.1" x 81.5" 915 x 765 x 2070mm	48" x 30.1" x 81.5" 1220 x 765 x 2070mm	72" x 30.1" x 81.5" 1829 x 765 x 2070mm
Packaging Dimensions	33.9" x 33.5" x 87.8" 862 x 850 x 2230mm	40" x 33.5" x 87.8" 1015 x 850 x 2230mm	52" x 33.5" x 87.8" 1320 x 850 x 2230mm	76" x 33.5" x 87.8" 1930 x 850 x 2230mm





# Technical Specifications

## BLACK UNITS

Model	RS-CN-0440-B	RS-CN-0530-B	RS-CN-0700-B	RS-CN-1050-B
Item Number	48480	48265	48266	48269
Rated Input Power	1700 W		2550 W	2400 W
Capacity	440 L / 15.53 cu.ft.	530 L / 18.71 cu.ft.	700 L / 24.72 cu.ft.	1050 L / 37.08 cu.ft.
Electrical	110-120V / 60Hz / 1		220V / 60Hz / 1	
Shelf Load Capacity	55.1 lbs. / 25 kgs.		66.1 lbs. / 30 kgs.	110.2 lbs. / 50 kgs.
Temperature Range	2 - 10°C / 35.6 - 50°F			
Max Ambient Temp Rating	24°C / 75°F			
Refrigerant & Injection	R290			
Type of Climate	3			
Rated Current	16A		12.1A	11.5A
Weight	276.7 lbs. / 125.5 kgs.	335.1 lbs. / 152 kgs.	426.6 lbs. / 193.5 kgs.	565.5 lbs. / 256.5 kgs.
Packaging Weight	332.9 lbs. / 151 kgs.	388 lbs. / 176 kgs.	486.1 lbs. / 220.5 kgs.	652.6 lbs. / 296 kgs.
Dimensions	30" x 30.1" x 81.5" 762 x 765 x 2070mm	36" x 30.1" x 81.5" 915 x 765 x 2070mm	48" x 30.1" x 81.5" 1220 x 765 x 2070mm	72" x 30.1" x 81.5" 1829 x 765 x 2070mm
Packaging Dimensions	33.9" x 33.5" x 87.8" 862 x 850 x 2230mm	40" x 33.5" x 87.8" 1015 x 850 x 2230mm	52" x 33.5" x 87.8" 1320 x 850 x 2230mm	76" x 33.5" x 87.8" 1930 x 850 x 2230mm

## Operation

### BEFORE USE

- Plug refrigerator into the exclusive socket.
- After the refrigerator is running, confirm that air suction/filtration is in working order and that it is sufficiently cold. After checking to make sure the refrigerator is working properly, it may be used.

# Operation

## DIGITAL TEMPERATURE CONTROLLER

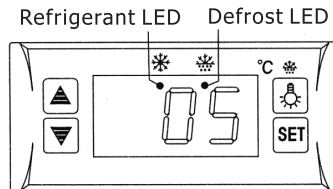

## FEATURES OF FUNCTION

- Small, integrated digital controller, which is applicable to the compressor of 1 HP. Located behind the front grill.
- Main functions are: temperature display, temperature control, manual-automatic, light control, value storing, self-testing, parameter locking.

## FRONT PANEL OPERATION

1. Set temperature: press **SET** button; set temperature will be displayed. Press **▲** or **▼** button to modify and store the displayed value. Press **SET** button to exit the adjustment and display the cold-room temperature.
2. If no button is pressed within 10 seconds, the cold-room temperature will be displayed.
3. Lighting: press **☹** button to activate light in refrigerator; press again to turn off. Manual start/stop defrost: press **☹** button and hold for 6 seconds to either defrost or to stop defrost.
4. Refrigeration LED: during refrigeration, the LED is on. When the cold room temperature is constant, the LED is off. During delay start, the LED flashes.
5. Defrost LED: during defrosting, the LED is on. When it stops defrosting, the LED is off. During the delay of defrost, the LED flashed.

## CAUTION

- Never block the air outlet and suction to keep the air circulation and refrigeration capability constant.
- Do not overfill refrigerator with food, as it will influence the cooling effect. If needed, adjust the rack height for proper food storage.
- Cool down hot food to room temperature before placing inside the refrigerator.
- When power supply has been cut off, reduce opening times and maintain cool temperature in refrigerator.
- To avoid scalding, never touch the compressor.
- If the supply cord is damaged, it must be replaced by the manufacturer, its service agent, or similarly qualified persons in order to avoid hazard.
- This appliance is not intended for use by persons (including children) with reduced physical, sensory or mental capabilities, or lack of experience and knowledge, unless they have been given supervision or instruction concerning use of the appliance by a person responsible for their safety.
- Children should be supervised to ensure that they do not play with the appliance.

# Maintenance

1. Cabinet Cleaning:
  - a. The product should be maintained and cleaned periodically with power supply disconnected. In cleaning, please use mild-rinsing water or non-corrosive products. Do not wash directly with water faucet.
  - b. Clean outside of unit using a soft cloth with neutral detergent, and dry with a separate soft cloth.
  - c. Clean inside racks by removing them from the unit and clean with water.
2. When shutting down unit for a long period of time, take out all food and unplug wall socket. Clean inside and outside thoroughly, and keep door open to sufficiently dry.
3. As glass breaks easily, keep far away from children.
4. Frequently observe the operation of the product. In case of any abnormal noise or smell, cut off the power supply immediately and call professionals. Do not restart the product before source of trouble is found.
5. We will not be responsible for any accidents acquired through failure to follow previous notices.

## SERVICE

- To maintain good refrigeration performance, a refrigeration service person should be called periodically (at least twice a year) to clean the discharge honeycomb and remove any accumulated dirt from the condenser coil and condensate evaporator pan on self-contained models. POOR CIRCULATION OF AIR THROUGH THE CONDENSER COIL WILL RESULT IN POOR REFRIGERATION PERFORMANCE.
- Dirt accumulation inside the condensate evaporator pan will reduce the pan's capacity and affect the efficiency of the heater causing a burned out heater and an overflow of defrost water onto the store floor.

# Troubleshooting

Trouble	Causes	Solutions
Strange noise under the bottom shelf.	Fan blade broken.	Power off and fix the blade.
Non-refrigerating in spite of normal operation.	Unit off.	Power on.
	Melting process.	Stop melting.
	Refrigerant leaking.	Patch the leak and refill refrigerant.
	Unit failure.	Call Omcan.
Weak air from air curtain, and higher cabinet temperature.	Evaporator blocked by frost.	Increase melting frequency.
	Inside fan damaged.	Replace the fan.
	Too low point of temperature controller.	Adjust the set point.
	Vent blocked by storage.	Remove the storage.

# Troubleshooting

Normal air curtain, but higher cabinet temperature.	Insufficient refrigerant.	Refill the refrigerant.
	Too high set point of temperature controllers.	Adjust the set point for the temperature controller.
	The wind curtain disturbed by strong air flow.	Removing the disturbing factors.
	Ambient temperature or humidity beyond standards.	Improve the conditions.
Melting water overflows.	Heating pipe for melting water damaged.	Replace the heating pipe.
	Water level controller failure.	Replace the water level controller.
	Ambient temperature or humidity beyond standards.	Improve the conditions.
Normal air curtain, but periodical fluctuation of cabinet temperature.	Condenser contaminated.	Clean the condenser.
	Poor venting of the unit.	Improve the venting conditions.
	Heat protection of compressor failure.	Replace the heat protection.
	Capillary is blocked by ice.	Replace the drying filter.
	Temperature controller failure.	Replace the temperature controller.
Water leaks on floor.	Ambient room temperature exceeds 75°F and 55% relative humidity.	Connect appliance drain to floor drain.

## NOTE

### Following occurrences are not problems:

- The murmur of water is heard when the refrigerator is working. It is a normal occurrence as the coolant is circulating in the system.
- When the weather is damp, condensation might be found on the outside of the refrigerator. It is caused by high humidity. Simply use cloth to wipe it off.

# Parts Breakdown

**Model RS-CN-0440** 48479

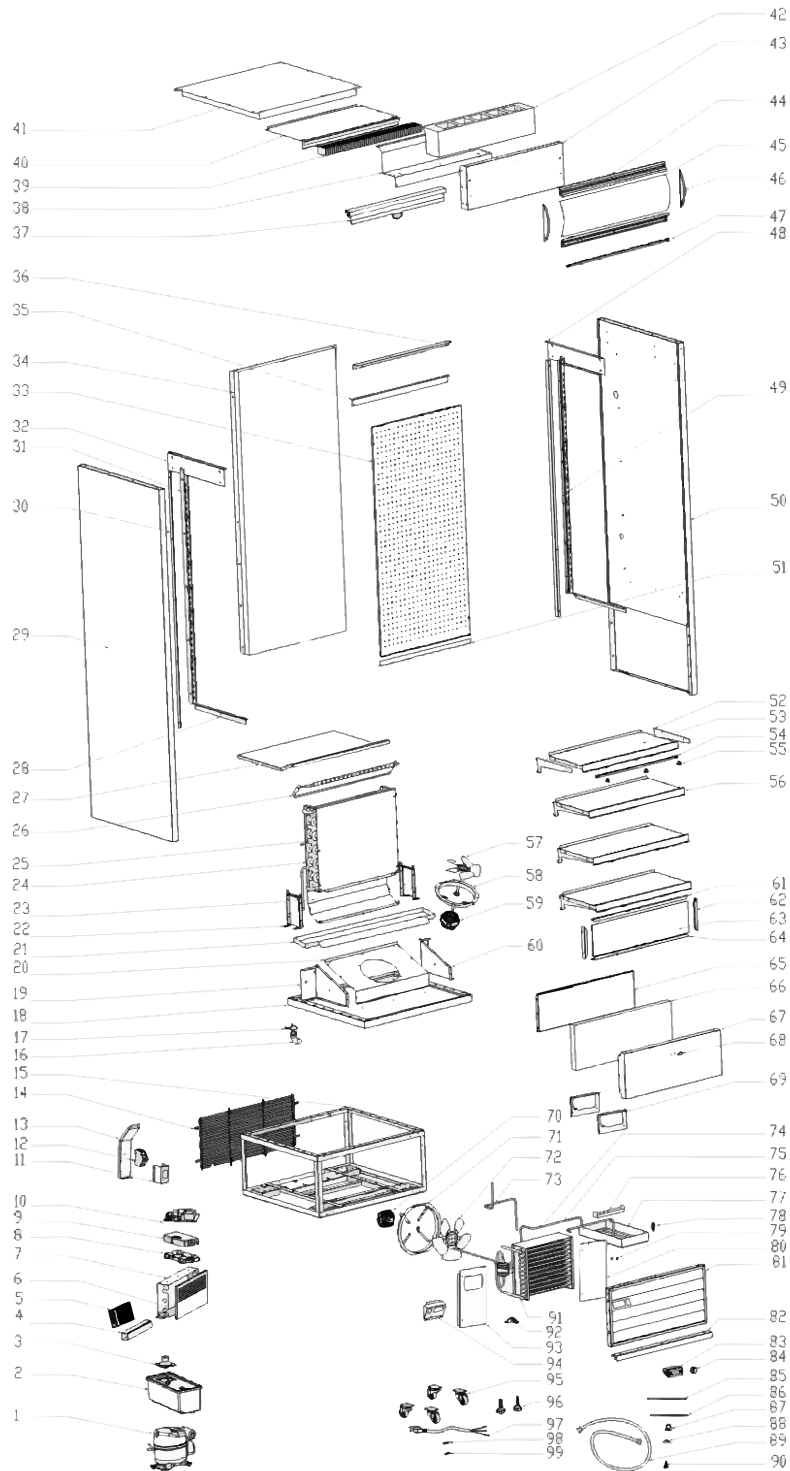

# Parts Breakdown

## Model RS-CN-0440 48479

Item No.	Description	Position	Item No.	Description	Position	Item No.	Description	Position
AP390	Compressor for 48479	1	AT371	Air Inlet Panel for 48479	27	AT387	General Assembly for Shelf for 48479	53
60587	Water Receiver for 48479	2	60610	Parry of Lower Air Intake for 48479	28	AT388	Constant Voltage Patch LED Light 2 for 48479	54
79304	Pipe for Evaporated Water for 48479	3	AO866	Foam of Left Side Board for 48479	29	AD500	Jump Ring of LED for 48479	55
60590	PVC Trucking for 48479	4	60613	Dead Plate of Rear Foam for 48479	30	AT389	Price Tag Holder for 48479	56
AT357	Switch Power Supply for 48479	5	AT372	Left Support Pillar of Shelf for 48479	31	79366	Fan Blade for 48479	57
AT358	Cover of Terminal Box for 48479	6	60615	Parry of Right Lining Plate for 48479	32	60641	Fan Guard for 48479	58
AO860	Wiring Box for 48479	7	AT373	Ventilated Board for 48479	33	AL374	Evaporator Fan Motor for 48479	59
61167	Circuit Board Box for 48479	8	AT374	Upper Back Plate for 48479	34	60643	Left Plate of Evaporator Motor for 48479	60
60594	Cover of Circuit Board Box for 48479	9	AT375	Damper of Back Foam for 48479	35	AT390	Decorating Strip of Glass Deflector for 48479	61
AF546	Main Circuit Board for 48479	10	AT376	Back Upper Crosspiece for 48479	36	60645	Strip of Glass Deflector for 48479	62
AT359	Leakage Circuit Breaker Cover for 48479	11	AT377	Night Curtain for 48479	37	AT391	Glass Deflector for 48479	63
AT360	Leakage Circuit Breaker for 48479	12	AT378	Damper of Upper Air Outlet for 48479	38	AT392	Strip of Glass Deflector for 48479	64
AT361	Leakage Circuit Breaker Fixing Plate for 48479	13	68470	Honeycomb Plate for 48479	39	AT393	Lower Front Board Component for 48479	65
AT362	Mesh Guard in Base for 48479	14	AT379	Cover of Upper Air Outlet for 48479	40	AT394	PE Cotton for Lower Front Board for 48479	66
AT363	Base for 48479	15	AT380	Upper Cover Plate for 48479	41	AT395	Lower Front Board for 48479	67
AO889	Water Pipe for 48479	16	60698	Lining Foam for 48479	42	60651	Curtain Hook for 48479	68
AL376	Circlip for 48479	17	AT381	Upper Front Board for 48479	43	68392	Water Box Bracket for 48479	69
AT364	Foam of Base Plate for 48479	18	AT382	Lampshade Frame for 48479	44	AD518	Condenser Fan Motor for 48479	70
60602	Left Board of Evaporator Cover for 48479	19	AT383	Lampshade for 48479	45	79365	Fan Guard for 48479	71
AT365	Evaporator Motor Cover for 48479	20	60628	Holder of Lampshade Frame for 48479	46	60640	Fan Blade for 48479	72
AT366	Evaporator Water Box for 48479	21	AT384	Constant Voltage Patch LED Light 1 for 48479	47	AT396	Connection Pipe for 48479	73
60604	Evaporator Holder for 48479	22	60629	Parry of Right Lining Plate for 48479	48	70106	Dry Filter for 48479	74
AT367	Evaporator Ventilation Damper for 48479	23	AT385	Right Support Pillar of Shelf for 48479	49	AT397	High Pressure Evaporation Tube for 48479	75
AT368	Evaporator for 48479	24	AO878	Foam of Right Board for 48479	50	60652	High Pressure Evaporation Tube Pressure Plate for 48479	76
AT369	Evaporator Damper for 48479	25	AT386	Rear Support of Air Inlet Panel for 48479	51	60655	Water Box for 48479	77
AT370	Evaporator Windshield for 48479	26	AO905	Left/Right Support Pillar of Shelf for 48479	52	AL306	Pagoda Water Mouth-Processing for 48479	78

# Parts Breakdown

## Model RS-CN-0440 48479

Item No.	Description	Position	Item No.	Description	Position	Item No.	Description	Position
68301	Strong Magnet for 48479	79	AD481	Overheating Probe for 48479	86	AT402	Left Windshield of Condenser for 48479	93
AT398	Right Windshield of Condenser for 48479	80	60670	PPR Tube Strap for 48479	87	60663	Switch Display Bracket for 48479	94
AT399	Shutter for 48479	81	60669	Pressing Plate of Dry Filter for 48479	88	AL357	Castor for 48479	95
AT400	Lower Front Crosspiece for 48479	82	60668	Drain Pipe for 48479	89	60672	Feet for 48479	96
67648	Temperature Display for 48479	83	68398	Copper Connection for 48479	90	AC057	Power Cord for 48479	97
AR485	Switch (Higher Amp) for 48479	84	AT401	Condenser for 48479	91	66095	Wire Clip Cover for 48479	98
60666	Temperature Probe for 48479	85	AO865	Filter Pressure Plate for 48479	92	61246	Wire Clip Holder for 48479	99

# Parts Breakdown

**Model RS-CN-0530** 43459

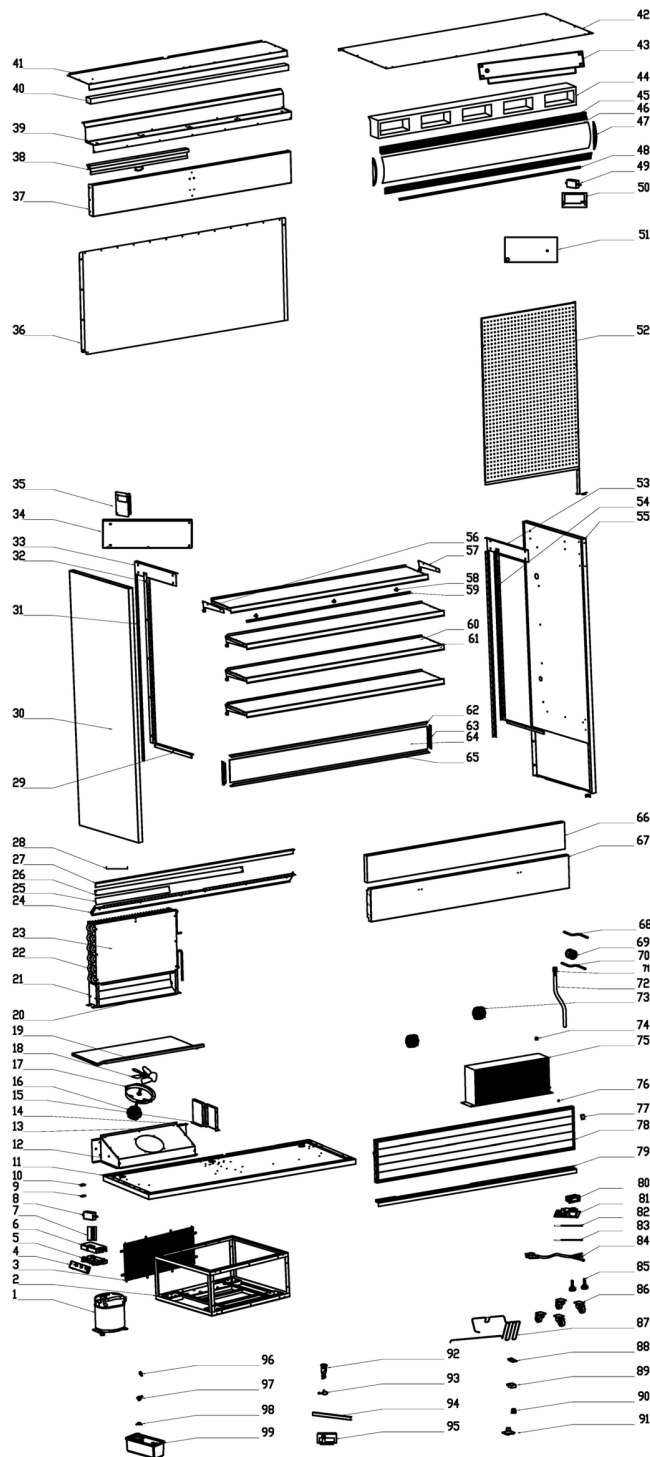



# Parts Breakdown

## Model RS-CN-0530 43459

Item No.	Description	Position	Item No.	Description	Position	Item No.	Description	Position
AP390	Compressor for 43459	1	60617	Rear Foam Baffle for 43459	26	A0876	Ventilated Board for 43459	52
AP391	Base for 43459	2	66096	Back Upper Crosspiece for 43459	27	60629	Parry of Right Lining Plate for 43459	53
60599	Mesh Guard in Base for 43459	3	A0865	Filter Pressure Plate for 43459	28	A0877	Right Support Pillar of Shelf for 43459	54
A0860	Wiring Box for 43459	4	60610	Parry of Lower Air Intake for 43459	29	A0878	Foam of Right Board for 43459	55
61167	Circuit Board Box for 43459	5	A0866	Foam of Left Side Board for 43459	30	AP395	Left Support Pillar of Shelf for 43459	56
60594	Cover of Circuit Board Box for 43459	6	60613	Dead Plate of Rear Foam for 43459	31	AP396	Right Support Pillar of Shelf for 43459	57
A0861	Cap of Juncting Box for 43459	7	A0867	Left Support Pillar of Shelf for 43459	32	AD500	Jump Ring of LED for 43459	58
A0862	LED Transformer for 43459	8, 49	60615	Parry of Right Lining Plate for 43459	33	A0881	Constant Voltage Patch LED Light for 43459	59
61246	Wire Clip Holder for 43459	9	AP392	Condensator Right Windshield for 43459	34	A0882	General Assembly for Shelves for 43459	60
66095	Wire Clip Cover for 43459	10	AP393	Left Windshield of Condenser for 43459	35	60639	Price Tag Holder for 43459	61
60601	Foam of Base Plate for 43459	11	A0869	Upper Back Plate for 43459	36	60644	Decorating Strip of Glass Deflector for 43459	62
60602	Left Board of Evaporator Cover for 43459	12	A0870	Upper Front Board for 43459	37	60647	Strip of Glass Deflector 2 for 43459	63
60603	Evaporator Cover for 43459	13	66097	Night Curtain for 43459	38	67644	Glass Deflector for 43459	64
60643	Right Plate of Evaporator Motor for 43459	14	AP394	Damper of Upper Air Outlet for 43459	39	60645	Strip of Glass Deflector for 43459	65
60632	Middle Support Pillar of Air Intake for 43459	15	66099	Honeycomb Panel for 43459	40	60649	PE for Lower Board for 43459	66
AL374	Evaporator Fan Motor for 43459	16	A0872	Cover of Upper Air Outlet for 43459	41	AP397	Lower Front Board for 43459	67
60641	Fan Guard for 43459	17	A0873	Upper Cover Plate for 43459	42	AP398	Capillary Filter Connection Tube for 43459	68
60640	Fan Blade for 43459	18	67647	The Left of the Evaporator Water Box for 43459	43	70106	Dry Filter for 43459	69
A0863	Plate of Left/Right Air Intake for 43459	19	60698	Lining Foam for 43459	44	AP399	Joint Pipe of Dry Filter for 43459	70
60605	Evaporator Ventilation Damper for 43459	20	60626	Lampshade Frame for 43459	45	AL576	Drain Joint for 43459	71
60604	Evaporator Holder for 43459	21	60627	Lampshade for 43459	46	60668	Drain Pipe for 43459	72
A0864	Evaporator for 43459	22	60628	Holder of Lampshade Frame for 43459	47	AD518	Condenser Fan Motor for 43459	73
60607	Evaporator Damper for 43459	23	A0874	Constant Voltage Patch LED Light for 43459	48	60633	Side Panel Connector for 43459	74
60608	Evaporator Wind Screen for 43459	24	68392	Water Box Bracket for 43459	50	AP401	Condenser for 43459	75
60648	Lower Front Baffle Assembly for 43459	25	60655	Water Box for 43459	51	68301	Strong Magnet for 43459	76

# Parts Breakdown

## Model RS-CN-0530 43459

Item No.	Description	Position	Item No.	Description	Position	Item No.	Description	Position
AR485	Switch (Higher Amp) for 43459	77	60672	Feet for 43459	84	A0889	Water Pipe for 43459	92
AP402	Switch Cover for 43459	78	AL357	Castor for 43459	85	AL376	Circlip for 43459	93
60660	Lower Front Waling for 43459	79	60653	High Pressure Evaporation Tube for 43459	86	60652	High Pressure Evaporation Tube Pressure Plate for 43459	94
AI123	Main Board for 43459	80	79359	Cover of Junction Box for 43459	87	AP403	Switch Display Bracket for 43459	95
67648	Temperature Display for 43459	80	61244	Terminal Box for 43459	88	AL306	Pagoda Water Mouth-Processing for 43459	96
60666	Temperature Probe for 43459	81	60590	PVC Trucking for 43459	89	68398	Copper Connection for 43459	97
A0887	Defrost Probe for 43459	82	60670	PPR Tube Strap for 43459	90	60669	Pressing Plate of Dry Filter for 43459	98
AC057	Power Cord for 43459	83	79304	Pipe for Evaporated Water for 43459	91	60587	Water Receiver for 43459	99

# Parts Breakdown

**Model RS-CN-0700** 41469

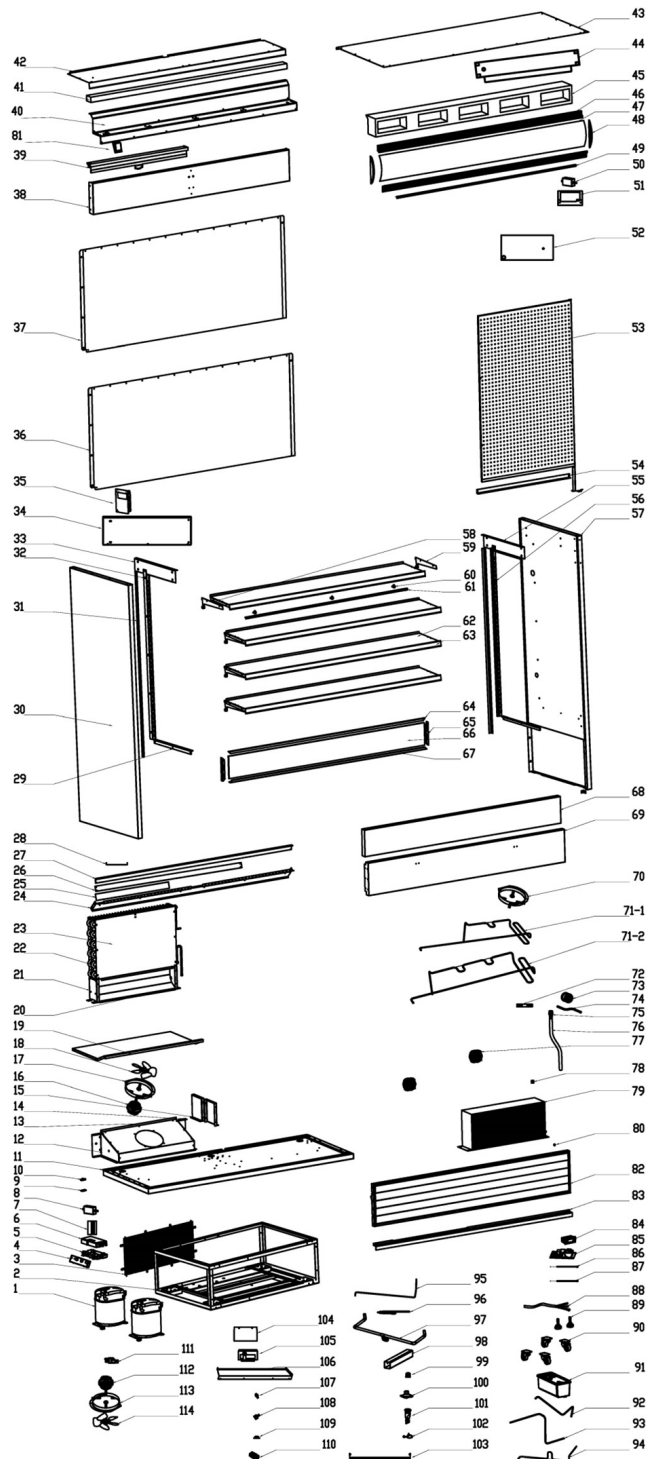

# Parts Breakdown

## Model RS-CN-0700 41469

Item No.	Description	Position	Item No.	Description	Position	Item No.	Description	Position
AP414	Compressor (R290) for 41469	1	70120	Rear Foam Baffle for 41469	26	60655	Water Box for 41469	52
AP415	Base for 41469	2	70143	Back Upper Crosspiece for 41469	27	AO904	Ventilated Board for 41469	53
70133	Mesh Guard in Base for 41469	3	AO865	Filter Pressure Plate for 41469	28	67662	Back Support for Board at Air Intake for 41469	54
AO860	Wiring Box for 41469	4	60610	Parry of Lower Air Intake for 41469	29	60629	Parry of Right Lining Plate for 41469	55
61167	Circuit Board Box for 41469	5	AO866	Foam of Left Side Board for 41469	30	AO877	Right Support Pillar of Shelf for 41469	56
60594	Cover of Circuit Board Box for 41469	6	60613	Dead Plate of Rear Foam for 41469	31	AO878	Foam of Right Board for 41469	57
AO861	Cap of Juncting Box for 41469	7	AO867	Left Support Pillar of Shelf for 41469	32	AO905	Left/Right Support Pillar of Shelf for 41469	58, 59
AO862	LED Transformer for 41469	8, 50	60615	Parry of Right Lining Plate for 41469	33	AD500	Jump Ring of LED for 41469	60
60676	Wire Clip Holder for 41469	9	AP417	Condensator Right Windshield for 41469	34	AO906	Constant Voltage Patch LED Light for 41469	61
60677	Wire Clip Cover for 41469	10	AP418	Left Windshield of Condenser for 41469	35	AO907	General Assembly for Shelves for 41469	62
67653	Foam of Base Plate for 41469	11	AO896	Lower Back Plate for 41469	36	67665	Price Tag Holder for 41469	63
60680	Left Board of Evaporator Cover for 41469	12	AO897	Upper Back Plate for 41469	37	70151	Decorating Strip of Glass Deflector for 41469	64
70154	Evaporator Cover for 41469	13	AO898	Upper Front Board for 41469	38	70149	Strip of Glass Deflector 2 for 41469	65
60681	Left Plate of Evaporator Motor for 41469	14	66104	Night Curtain for 41469	39	67666	Glass Deflector for 41469	66
60684	Middle Support Pillar of Air Intake for 41469	15	AO899	Damper of Upper Air Outlet for 41469	40	60645	Strip of Glass Deflector for 41469	67
AO892	Evaporator Fan Motor for 41469	16, 77	67660	Honeycomb Panel for 41469	41	67667	PE for Lower Board for 41469	68
60641	Fan Guard for 41469	17, 70	AO900	Cover of Upper Air Outlet for 41469	42	AO908	Lower Front Board for 41469	69
60640	Fan Blade for 41469	18	AP419	Upper Cover Plate for 41469	43	AP420	Right High Voltage Evaporating Pipe for 41469	71--1
AO893	Plate of Left/Right Air Intake for 41469	19	AO902	The Left of the Evaporator Water Box for 41469	44	AP421	Left High Voltage Evaporating Pipe for 41469	71--2
67654	Evaporator Ventilation Damper for 41469	20	60698	Lining Foam for 41469	45	AO890	Drainage Pipe Bracket for 41469	72
60604	Evaporator Holder for 41469	21	70141	Lampshade Frame for 41469	46	70106	Dry Filter for 41469	73
AP416	Evaporator for 41469	22	70142	Lampshade for 41469	47	AP422	Joint Pipe of Dry Filter for 41469	74
67655	Evaporator Damper for 41469	23	60628	Holder of Lampshade Frame for 41469	48	AL576	Drain Joint for 41469	75
67656	Evaporator Wind Screen for 41469	24	AO903	Constant Voltage Patch LED Advertising Board Light for 41469	49	60668	Drain Pipe for 41469	76
70153	Lower Front Baffle Assembly for 41469	25	68392	Water Box Bracket for 41469	51	60633	Side Plate Connector for 41469	78

# Parts Breakdown

## Model RS-CN-0700 41469

Item No.	Description	Position	Item No.	Description	Position	Item No.	Description	Position
AP423	Condenser for 41469	79	67651	Water Connection Box Component for 41469	91	60652	High Pressure Evaporation Tube Pressure Plate for 41469	103
68301	Strong Magnet for 41469	80	AP425	Connecting Tube for Right Condenser and Dry Filter for 41469	92	AP430	Baffle Board of Evaporator Motor for 41469	104
AR485	Switch (Higher Amp) for 41469	81	AP426	Connecting Tube for Left Condenser and Dry Filter for 41469	93	AP403	Switch Display Bracket for 41469	105
AO910	Switch Cover for 41469	82	AP427	Right Air Return Duct for 41469	94	AP431	Top Baffle Board of Condenser for 41469	106
70127	Lower Front Waling for 41469	83	AP428	Left Air Return Duct for 41469	95	AL306	Pagoda Water Mouth-Processing for 41469	107
67648	Temperature Display for 41469	84	AP429	Tee Joint for 41469	96	68398	Copper Connection for 41469	108
AP424	Main Circuit Board for 41469	85	AO888	PVC Tube for 41469	97	60669	Pressing Plate of Dry Filter for 41469	109
60666	Temperature Probe for 41469	86	60590	PVC Trucking for 41469	98	AP432	WAGO Wire Connector for 41469	110
AO887	Defrost Probe for 41469	87	60670	PPR Tube Strap for 41469	99	AP433	American Plug for 41469	111
AO911	Power Cord for 41469	88	79304	Pipe for Evaporated Water for 41469	100	70111	Fan Motor for 41469	112
60672	Feet for 41469	89	AO889	Water Pipe for 41469	101	60932	Fan Guard for 41469	113
AL357	Castor for 41469	90	AL376	Circlip for 41469	102	60933	Fan Blade for 41469	114

# Parts Breakdown

**Model RS-CN-1050** 43460

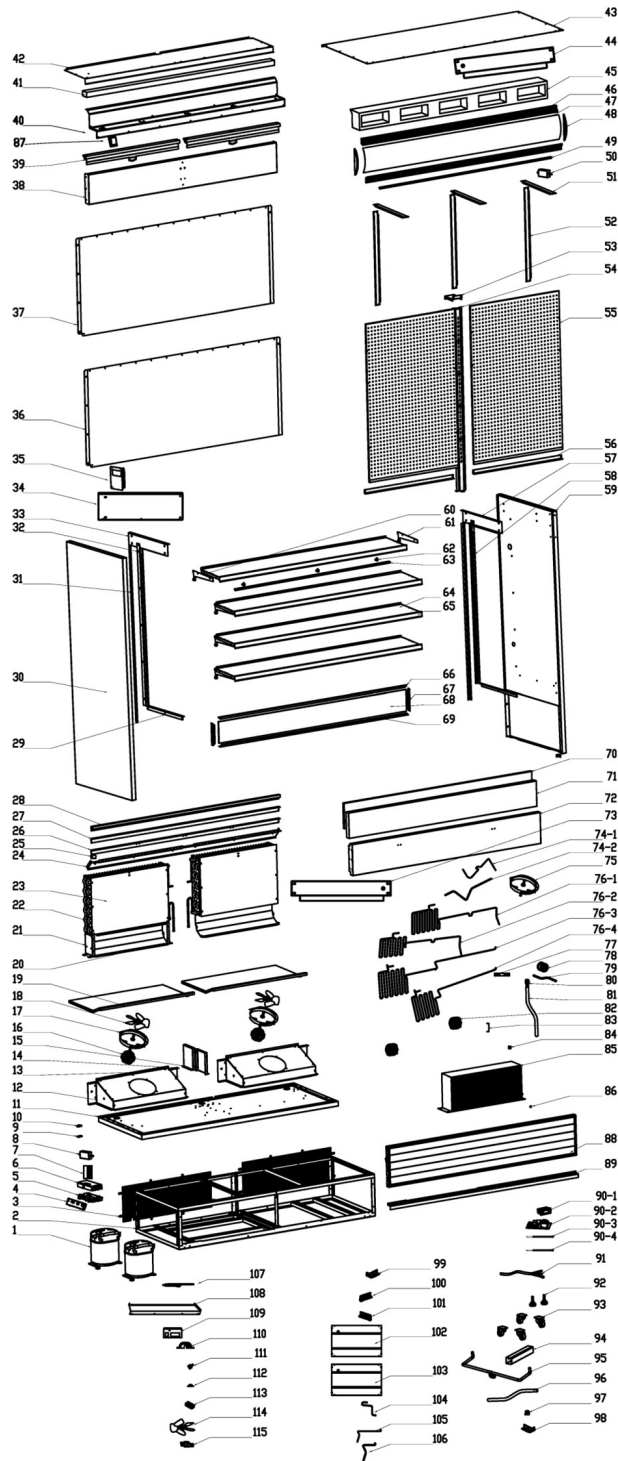

# Parts Breakdown

## Model RS-CN-1050 43460

Item No.	Description	Position	Item No.	Description	Position	Item No.	Description	Position
AP414	Compressor (R290) for 43460	1	67676	Crosspiece of Back Foam for 43460	26	67684	Vertical Plate of Back Foam for 43460	52
AP434	Base for 43460	2	66105	Back Upper Crosspiece for 43460	27	60686	Holding Plate of Back Foam Crosspiece for 43460	53
60599	Mesh Guard in Base for 43460	3	67677	Thicker Crosspiece of Back Ventilated Board for 43460	28	AO922	Middle Support Pillar of Shelf for 43460	54
AO860	Wiring Box for 43460	4	60610	Parry of Lower Air Intake for 43460	29	AO923	Ventilated Board for 43460	55
61167	Circuit Board Box for 43460	5	AO866	Foam of Left Side Board for 43460	30	60703	Back Support for Board at Air Intake for 43460	56
60594	Cover of Circuit Board Box for 43460	6	60613	Dead Plate of Rear Foam for 43460	31	60629	Parry of Right Lining Plate for 43460	57
AO861	Cap of Juncting Box for 43460	7	AO867	Left Support Pillar of Shelf for 43460	32	AO877	Right Support Pillar of Shelf for 43460	58
AO862	LED Transformer for 43460	8, 50	60615	Parry of Right Lining Plate for 43460	33	AO878	Foam of Right Board for 43460	59
60676	Wire Clip Holder for 43460	9	AP435	Right Windshield of Condenser for 43460	34	AO905	Left/Right Support Pillar of Shelf for 43460	60, 61
60677	Wire Clip Cover for 43460	10	AP436	Left Windshield of Condenser for 43460	35	AP437	Jump Ring of LED for 43460	62
60679	Foam of Base Plate for 43460	11	AO914	Lower Back Plate for 43460	36	AO924	LED for 43460	63
60680	Left Board of Evaporator Cover for 43460	12	AO915	Upper Back Plate for 43460	37	AP438	General Assembly for Shelves for 43460	64
60603	Evaporator Cover for 43460	13	AO916	Upper Front Board for 43460	38	60709	Price Tag Holder for 43460	65
60681	Left Plate of Evaporator Motor for 43460	14	60692	Night Curtain for 43460	39	60712	Decorating Strip of Glass Deflector for 43460	66
60684	Middle Support Pillar of Air Intake for 43460	15	AO917	Damper of Upper Air Outlet for 43460	40	60710	Strip of Glass Deflector 2 for 43460	67
AO892	Evaporator Fan Motor for 43460	16	60694	Honeycomb Panel for 43460	41	67686	Glass Deflector for 43460	68
60932	Fan Guard for 43460	17	AO918	Cover of Upper Air Outlet for 43460	42	60645	Strip of Glass Deflector for 43460	69
60640	Fan Blade for 43460	18	AO919	Upper Cover Plate for 43460	43	60713	Lower Front Board Components for 43460	70
AO875	Plate of Left/Right Air Intake for 43460	19	AO920	The Left of the Evaporator Water Box for 43460	44	60714	PE for Lower Board for 43460	71
60605	Evaporator Ventilation Damper for 43460	20	60698	Lining Foam for 43460	45	AO926	Lower Front Board for 43460	72
60604	Evaporator Holder for 43460	21	60700	Lampshade Frame for 43460	46	AO927	The Right Side of the Evaporator Water Box for 43460	73
AO864	Evaporator for 43460	22	60701	Lampshade for 43460	47	AP439	Right Joint Pipe of Compressor for 43460	74-1
60607	Evaporator Damper for 43460	23	60628	Holder of Lampshade Frame for 43460	48	AP440	Left Joint Pipe of Compressor for 43460	74-2
60683	Evaporator Wind Screen for 43460	24	AO921	LED in Light Box for 43460	49	60641	Fan Guard for 43460	75
AO912	Shock-Absorbing Parts for 43460	25	60696	Vertical Plate of Upper Foam for 43460	51	AP441	Right Bottom High Pressure Evaporating Tube for 43460	76-1

# Parts Breakdown

## Model RS-CN-1050 43460

Item No.	Description	Position	Item No.	Description	Position	Item No.	Description	Position
AP442	Left Bottom High Pressure Evaporating Tube for 43460	76-2	60721	Lower Front Waling for 43460	89	AP448	Left Front Bracket of Evaporating Pan for 43460	101
AP443	Right Top High Pressure Evaporating Tube for 43460	76-3	67648	Temperature Display for 43460	90-1	AP449	Bottom Evaporating Pan Assembly for 43460	102
AP444	Left Top High Pressure Evaporating Tube for 43460	76-4	AP424	Main Circuit Board for 43460	90-2	AP450	Top Evaporating Pan Assembly for 43460	103
A0929	The Bracket on the Water Pipe for 43460	77	A0934	Temperature Probe for 43460	90-3	AP451	High Pressure Evaporation Connect Tube for 43460	104
70106	Dry Filter for 43460	78	A0887	Defrost Probe for 43460	90-4	AP452	Connecting Tube for Right Condenser and Dry Filter for 43460	105
AP422	Joint Pipe of Dry Filter for 43460	79	AC057	Power Cord for 43460	91	AP453	Connecting Tube for Left Condenser and Dry Filter for 43460	106
A0930	Drain Joint for 43460	80	60672	Feet for 43460	92	AP429	Tee Joint for 43460	107
A0931	Drain Pipe for 43460	81	AL357	Castor for 43460	93	AP454	Top Baffle Board of Condenser for 43460	108
70111	Fan Motor for 43460	82	60590	PVC Trucking for 43460	94	AP403	Switch Display Bracket for 43460	109
A0932	Under-Wear Pipe Bracket for 43460	83	A0888	PVC Pipe for 43460	95	A0865	Filter Pressure Plate for 43460	110
60633	Side Panel Connector for 43460	84	60668	Drain Pipe for 43460	96	68398	Copper Connection for 43460	111
AP423	Condenser for 43460	85	60670	PPR Tube Strap for 43460	97	60669	Pressing Plate of Dry Filter for 43460	112
68301	Strong Magnet for 43460	86	AP445	Right Rear Bracket of Evaporating Pan for 43460	98	AP432	WAGO Wire Connector for 43460	113
AR485	Switch (Higher Amp) for 43460	87	AP446	Right Front Bracket of Evaporating Pan for 43460	99	60933	Fan Blade for 43460	114
A0933	Switch Cover for 43460	88	AP447	Left Rear Bracket of Evaporating Pan for 43460	100	AP433	American Plug for 43460	115



# Parts Breakdown

**Model RS-CN-0440-B** 48480

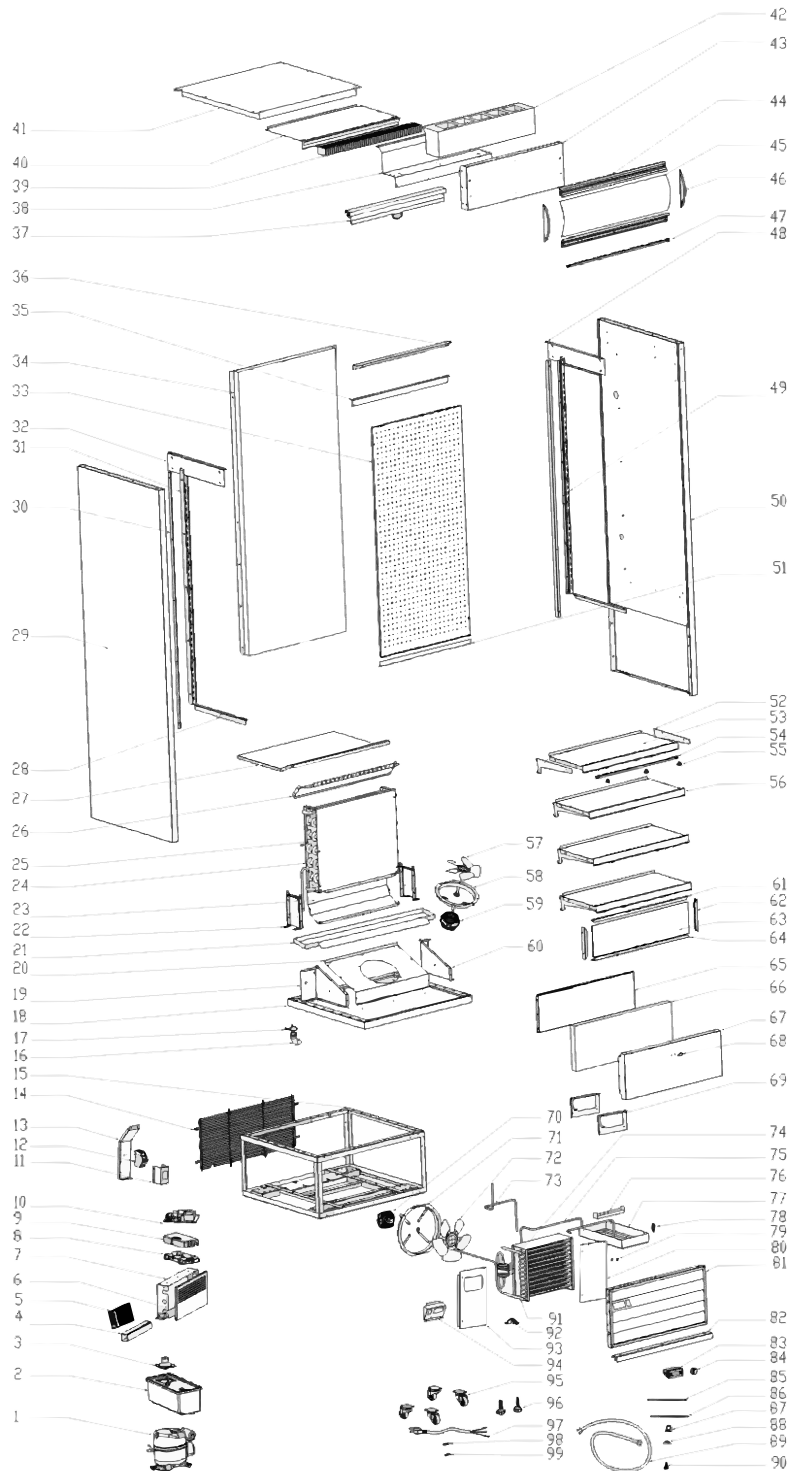

# Parts Breakdown

## Model RS-CN-0440-B 48480

Item No.	Description	Position	Item No.	Description	Position	Item No.	Description	Position
AP390	Compressor for 48480	1	AT370	Evaporator Windshield for 48480	26	AT386	Rear Support of Air Inlet Panel for 48480	51
60587	Water Receiver for 48480	2	AT403	Air Inlet Panel - Plastic Coated for 48480	27	AT410	Support Pillar of Shelf - Plastic Coated for 48480	52
79304	Pipe for Evaporated Water for 48480	3	60610	Parry of Lower Air Intake for 48480	28	AT411	General Assembly for Shelf - Plastic Coated for 48480	53
60590	PVC Trucking for 48480	4	AQ661	Left Side Board for 48480	29	AT388	Constant Voltage Patch LED Light 2 for 48480	54
AT357	Switch Power Supply for 48480	5	60613	Dead Plate of Rear Foam for 48480	30	AD500	Jump Ring of LED for 48480	55
AT358	Cover of Terminal Box for 48480	6	AQ662	Left Support Pillar of Shelf for 48480	31	AT389	Price Tag Holder for 48480	56
AO860	Wiring Box for 48480	7	60615	Parry of Right Lining Plate for 48480	32	79366	Fan Blade for 48480	57
61167	Circuit Board Box for 48480	8	AT404	Ventilated Board - Plastic Coated for 48480	33	60641	Fan Guard for 48480	58
60594	Cover of Circuit Board Box for 48480	9	AT405	Upper Back Plate for 48480	34	AL374	Evaporator Fan Motor for 48480	59
AF546	Main Circuit Board for 48480	10	AT375	Damper of Back Foam for 48480	35	60643	Left Plate of Evaporator Motor for 48480	60
AT359	Leakage Circuit Breaker Cover for 48480	11	AT376	Back Upper Crosspiece for 48480	36	AT390	Decorating Strip of Glass Deflector for 48480	61
AT360	Leakage Circuit Breaker for 48480	12	AT377	Night Curtain for 48480	37	60645	Strip of Glass Deflector for 48480	62
AT361	Leakage Circuit Breaker Fixing Plate for 48480	13	AT406	Damper of Upper Air Outlet - Plastic Coated for 48480	38	AT391	Glass Deflector for 48480	63
AT362	Mesh Guard in Base for 48480	14	68470	Honeycomb Plate for 48480	39	AT392	Strip of Glass Deflector for 48480	64
AT363	Base for 48480	15	AT407	Cover of Upper Air Outlet - Plastic Coated for 48480	40	AT393	Lower Front Board Component for 48480	65
AO889	Water Pipe for 48480	16	AT408	Upper Cover Plate for 48480	41	AT394	PE Cotton for Lower Front Board for 48480	66
AL376	Circlip for 48480	17	60698	Lining Foam for 48480	42	AT412	Lower Front Board - Plastic Coated for 48480	67
AT364	Foam of Base Plate for 48480	18	AT409	Upper Front Board - Plastic Coated for 48480	43	AT413	Curtain Hook - Plastic Coated for 48480	68
60602	Left Board of Evaporator Cover for 48480	19	AT382	Lampshade Frame for 48480	44	68392	Water Box Bracket for 48480	69
AT365	Evaporator Motor Cover for 48480	20	AT383	Lampshade for 48480	45	AD518	Condenser Fan Motor for 48480	70
AT366	Evaporator Water Box for 48480	21	60628	Holder of Lampshade Frame for 48480	46	79365	Fan Guard for 48480	71
60604	Evaporator Holder for 48480	22	AT384	Constant Voltage Patch LED Light 1 for 48480	47	60640	Fan Blade for 48480	72
AT367	Evaporator Ventilation Damper for 48480	23	60629	Parry of Right Lining Plate for 48480	48	AT396	Connection Pipe for 48480	73
AT368	Evaporator for 48480	24	AQ669	Right Support Pillar of Shelf for 48480	49	70106	Dry Filter for 48480	74
AT369	Evaporator Damper for 48480	25	AQ670	Right Side Board for 48480	50	AT397	High Pressure Evaporation Tube for 48480	75

# Parts Breakdown

## Model RS-CN-0440-B 48480

Item No.	Description	Position	Item No.	Description	Position	Item No.	Description	Position
60652	High Pressure Evaporation Tube Pressure Plate for 48480	76	AR485	Switch (Higher Amp) for 48480	84	A0865	Filter Pressure Plate for 48480	92
60655	Water Box for 48480	77	60666	Temperature Probe for 48480	85	AT402	Left Windshield of Condenser for 48480	93
AL306	Pagoda Water Mouth-Processing for 48480	78	AD481	Overheating Probe for 48480	86	60663	Switch Display Bracket for 48480	94
68301	Strong Magnet for 48480	79	60670	PPR Tube Strap for 48480	87	AL357	Castor for 48480	95
AT398	Right Windshield of Condenser for 48480	80	60669	Pressing Plate of Dry Filter for 48480	88	60672	Feet for 48480	96
AT414	Shutter - Plastic Coated for 48480	81	60668	Drain Pipe for 48480	89	AC057	Power Cord for 48480	97
AT415	Lower Front Crosspiece - Plastic Coated for 48480	82	68398	Copper Connection for 48480	90	66095	Wire Clip Cover for 48480	98
67648	Temperature Display for 48480	83	AT401	Condenser for 48480	91	61246	Wire Clip Holder for 48480	99

# Parts Breakdown

**Model RS-CN-0530-B** 48265

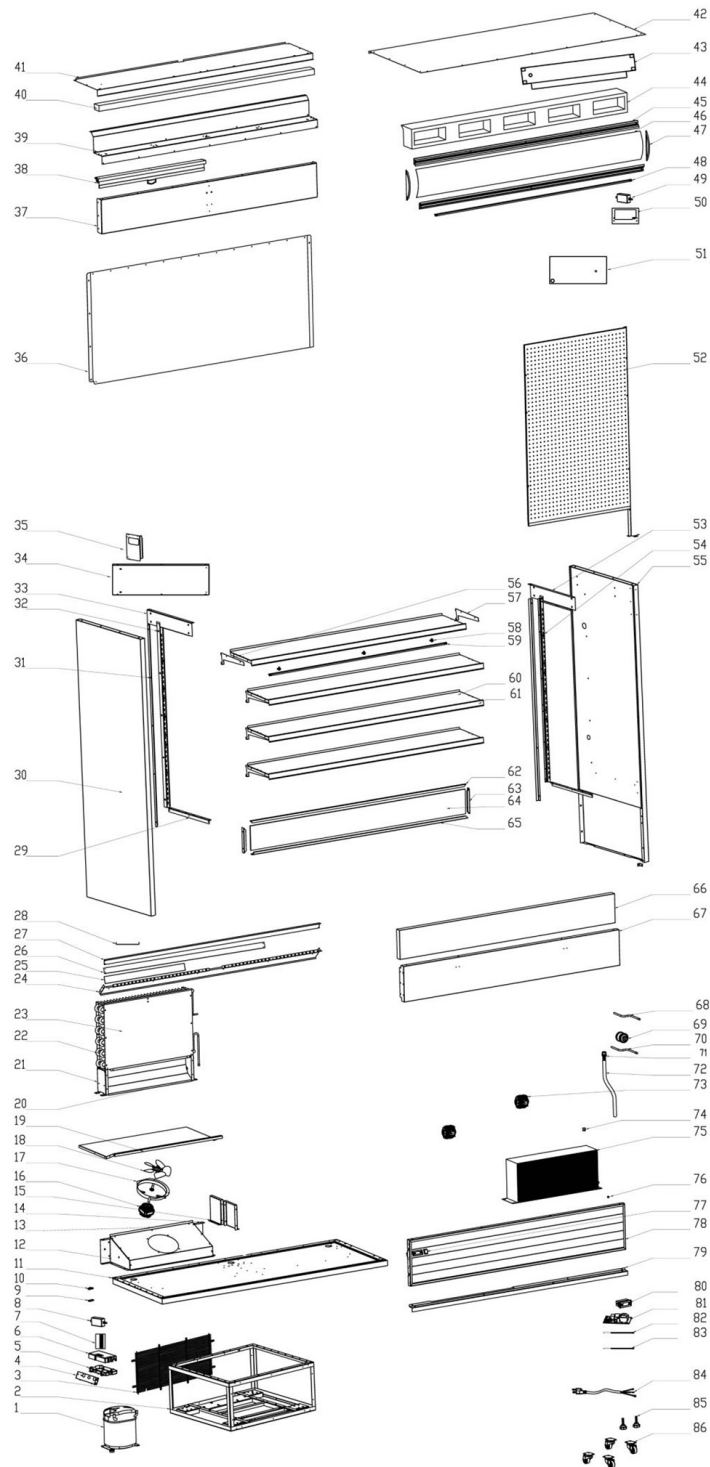

# Parts Breakdown

## Model RS-CN-0530-B 48265

Item No.	Description	Position	Item No.	Description	Position	Item No.	Description	Position
AP390	Compressor for 48265	1	60617	Rear Foam Baffle for 48265	26	A0876	Ventilated Board for 48265	52
AP391	Base for 48265	2	66096	Back Upper Crosspiece for 48265	27	60629	Parry of Right Lining Plate for 48265	53
60599	Mesh Guard in Base for 48265	3	A0865	Filter Pressure Plate for 48265	28	AQ669	Right Support Pillar of Shelf for 48265	54
A0860	Wiring Box for 48265	4	60610	Parry of Lower Air Intake for 48265	29	AQ670	Right Side Board for 48265	55
61167	Circuit Board Box for 48265	5	AQ661	Left Side Board for 48265	30	AP395	Left Support Pillar of Shelf for 48265	56
60594	Cover of Circuit Board Box for 48265	6	60613	Dead Plate of Rear Foam for 48265	31	AP396	Right Support Pillar of Shelf for 48265	57
A0861	Cap of Juncting Box for 48265	7	AQ662	Left Support Pillar of Shelf for 48265	32	AD500	Jump Ring of LED for 48265	58
A0862	LED Transformer for 48265	8, 49	60615	Parry of Right Lining Plate for 48265	33	AQ671	Constant Voltage Patch LED Light for 48265	59
61246	Wire Clip Holder for 48265	9	AP392	Condensator Right Windshield for 48265	34	A0882	General Assembly for Shelves for 48265	60
66095	Wire Clip Cover for 48265	10	AP393	Left Windshield of Condenser for 48265	35	60639	Price Tag Holder for 48265	61
60601	Foam of Base Plate for 48265	11	AQ663	Upper Back Plate for 48265	36	60644	Decoration Strip of Glass Deflector for 48265	62
60602	Left Board of Evaporator Cover for 48265	12	AQ664	Upper Front Board for 48265	37	60647	Strip of Glass Deflector 2 for 48265	63
60603	Evaporator Cover for 48265	13	66097	Night Curtain for 48265	38	AQ672	Glass Deflector for 48265	64
60643	Left Plate of Evaporator Motor for 48265	14	AQ665	Damper of Upper Air Outlet for 48265	39	60645	Strip of Glass Deflector for 48265	65
60632	Middle Support Pillar of Air Intake for 48265	15	66099	Honeycomb Panel for 48265	40	60649	PE for Lower Board for 48265	66
AL374	Evaporator Fan Motor for 48265	16	AQ666	Cover of Upper Air Outlet for 48265	41	AQ673	Lower Front Board for 48265	67
60641	Fan Guard for 48265	17	AQ667	Upper Cover Plate for 48265	42	AP398	Capillary Filter Connection Tube for 48265	68
60640	Fan Blade for 48265	18	67647	The Left of the Evaporator Water Box for 48265	43	70106	Dry Filter for 48265	69
AQ660	Plate of Left/Right Air Intake for 48265	19	60698	Lining Foam for 48265	44	AP399	Joint Pipe of Dry Filter for 48265	70
60605	Evaporator Ventilation Damper for 48265	20	60626	Lampshade Frame for 48265	45	AL576	Drain Joint for 48265	71
60604	Evaporator Holder for 48265	21	60627	Lampshade for 48265	46	60668	Drain Pipe for 48265	72
A0864	Evaporator for 48265	22	60628	Holder of Lampshade Frame for 48265	47	AD518	Condenser Fan Motor for 48265	73
60607	Evaporator Damper for 48265	23	AQ668	Constant Voltage Patch LED Light for 48265	48	60633	Side Plate Connector for 48265	74
60608	Evaporator Wind Screen for 48265	24	68392	Water Box Bracket for 48265	50	AP401	Condenser for 48265	75
60648	Lower Front Baffle Assembly for 48265	25	60655	Water Box for 48265	51	68301	Strong Magnet for 48265	76

# Parts Breakdown

## Model RS-CN-0530-B 48265

Item No.	Description	Position	Item No.	Description	Position	Item No.	Description	Position
AR485	Switch (Higher Amp) for 48265	77	AL357	Castor for 48265	86	A0889	Water Pipe for 48265	95
AQ674	Window Shutter for 48265	78	60653	High Pressure Evaporation Tube for 48265	87	AL376	Circlip for 48265	96
AQ675	Lower Front Crosspiece for 48265	79	79359	Cover of Junction Box for 48265	88	A0890	Drainage Pipe Bracket for 48265	97
67648	Temperature Display for 48265	80	61244	Terminal Box for 48265	89	60652	High Pressure Evaporation Tube Pressure Plate for 48265	98
AF546	Main Circuit Board for 48265	81	A0888	PVC Pipe for 48265	90	60663	Switch Display Bracket for 48265	99
60666	Temperature Probe for 48265	82	60590	PVC Trucking for 48265	91	AL306	Pagoda Water Mouth-Processing for 48265	100
A0887	Defrost Probe for 48265	83	71518	Nut for 48265	92	68398	Copper Connection for 48265	101
AC057	Power Cord for 48265	84	60670	PPR Tube Strap for 48265	93	60669	Pressing Plate of Dry Filter for 48265	102
60672	Feet for 48265	85	79304	Pipe for Evaporated Water for 48265	94			

# Parts Breakdown

**Model RS-CN-0700-B** 48266

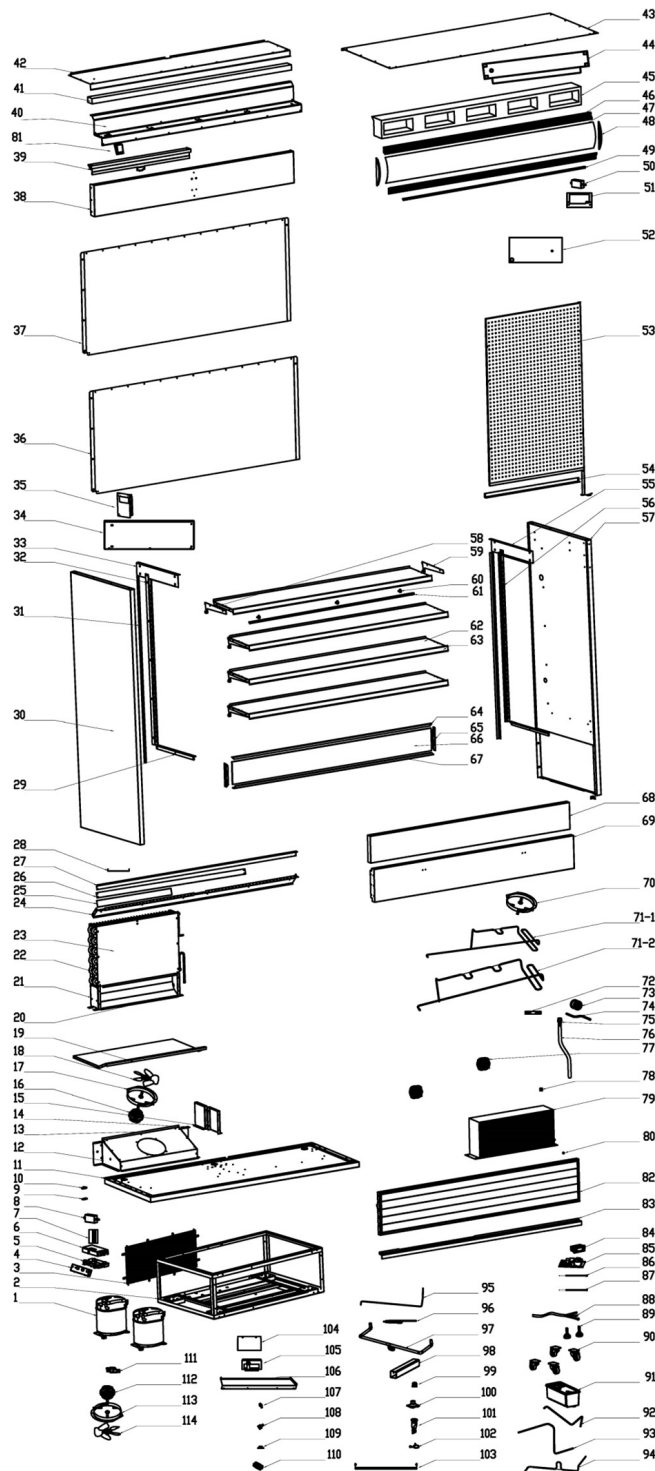

# Parts Breakdown

## Model RS-CN-0700-B 48266

Item No.	Description	Position	Item No.	Description	Position	Item No.	Description	Position
AP414	Compressor (R290) for 48266	1	70120	Rear Foam Baffle for 48266	26	60655	Water Box for 48266	52
AP415	Base for 48266	2	70143	Back Upper Crosspiece for 48266	27	AQ684	Ventilated Board for 48266	53
70133	Mesh Guard in Base for 48266	3	A0865	Filter Pressure Plate for 48266	28	67662	Back Support for Board at Air Intake for 48266	54
A0860	Wiring Box for 48266	4	60610	Parry of Lower Air Intake for 48266	29	60629	Parry of Right Lining Plate for 48266	55
61167	Circuit Board Box for 48266	5	AQ661	Left Side Board for 48266	30	AQ669	Right Support Pillar of Shelf for 48266	56
60594	Cover of Circuit Board Box for 48266	6	60613	Dead Plate of Rear Foam for 48266	31	AQ670	Right Side Board for 48266	57
A0861	Cap of Juncting Box for 48266	7	AQ662	Left Support Pillar of Shelf for 48266	32	A0905	Left/Right Support Pillar of Shelf for 48266	58, 59
A0862	LED Transformer for 48266	8, 50	60615	Parry of Right Lining Plate for 48266	33	AD500	Jump Ring of LED for 48266	60
60676	Wire Clip Holder for 48266	9	AP417	Condensator Right Windshield for 48266	34	A0906	Constant Voltage Patch LED Light for 48266	61
60677	Wire Clip Cover for 48266	10	AQ677	Left Windshield of Condenser for 48266	35	A0907	General Assembly for Shelves for 48266	62
67653	Foam of Base Plate for 48266	11	AQ678	Lower Back Plate for 48266	36	67665	Price Tag Holder Black for 48266	63
60680	Left Board of Evaporator Cover for 48266	12	AQ679	Upper Back Plate for 48266	37	70151	Decorating Strip of Glass Deflector for 48266	64
70154	Evaporator Cover for 48266	13	AQ680	Upper Front Board for 48266	38	70149	Strip of Glass Deflector 2 for 48266	65
60681	Left Plate of Evaporator Motor for 48266	14	66104	Night Curtain for 48266	39	67666	Glass Deflector for 48266	66
60684	Middle Support Pillar of Air Intake for 48266	15	AQ681	Damper of Upper Air Outlet for 48266	40	60645	Strip of Glass Deflector for 48266	67
A0892	Evaporator Fan Motor for 48266	16, 77	67660	Honeycomb Panel for 48266	41	67667	PE for Lower Board for 48266	68
60641	Fan Guard for 48266	17, 70	AQ682	Cover of Upper Air Outlet for 48266	42	AQ685	Lower Front Board for 48266	69
60640	Fan Blade for 48266	18	AQ683	Upper Cover Plate for 48266	43	AP420	Right High Voltage Evaporating Pipe for 48266	71--1
AQ676	Plate of Left/Right Air Intake for 48266	19	A0902	The Left of the Evaporator Water Box for 48266	44	AP421	Left High Voltage Evaporating Pipe for 48266	71--2
67654	Evaporator Ventilation Damper for 48266	20	60698	Lining Foam for 48266	45	A0890	Drainage Pipe Bracket for 48266	72
60604	Evaporator Holder for 48266	21	70141	Lampshade Frame for 48266	46	70106	Dry Filter for 48266	73
AP416	Evaporator for 48266	22	70142	Lampshade for 48266	47	AP422	Joint Pipe of Dry Filter for 48266	74
67655	Evaporator Damper for 48266	23	60628	Holder of Lampshade Frame for 48266	48	AL576	Drain Joint for 48266	75
67656	Evaporator Wind Screen for 48266	24	A0903	Constant Voltage Patch LED Advertising Board Light for 48266	49	60668	Drain Pipe for 48266	76
70153	Lower Front Baffle Assembly for 48266	25	68392	Water Box Bracket for 48266	51	60633	Side Plate Connector for 48266	78



# Parts Breakdown

## Model RS-CN-0700-B 48266

Item No.	Description	Position	Item No.	Description	Position	Item No.	Description	Position
AP423	Condenser for 48266	79	67651	Water Connection Box Component for 48266	91	60652	High Pressure Evaporation Tube Pressure Plate for 48266	103
68301	Strong Magnet for 48266	80	AP425	Connecting Tube for Right Condenser and Dry Filter for 48266	92	AP430	Baffle Board of Evaporator Motor for 48266	104
AR485	Switch (Higher Amp) for 48266	81	AP426	Connecting Tube for Left Condenser and Dry Filter for 48266	93	AP403	Switch Display Bracket for 48266	105
AQ686	Window Shutter for 48266	82	AP427	Right Air Return Duct for 48266	94	AP431	Top Baffle Board of Condenser for 48266	106
AQ687	Lower Front Crosspiece for 48266	83	AP428	Left Air Return Duct for 48266	95	AL306	Pagoda Water Mouth-Processing for 48266	107
67648	Temperature Display for 48266	84	AP429	Tee Joint for 48266	96	68398	Copper Connection for 48266	108
AP424	Main Circuit Board for 48266	85	A0888	PVC Pipe for 48266	97	60669	Pressing Plate of Dry Filter for 48266	109
60666	Temperature Probe for 48266	86	60590	PVC Trucking for 48266	98	AP432	Wago Wire Connector for 48266	110
A0887	Defrost Probe for 48266	87	60670	PPR Tube Strap for 48266	99	AP433	American Plug for 48266	111
A0911	Power Cord for 48266	88	79304	Pipe for Evaporated Water for 48266	100	70111	Fan Motor for 48266	112
60672	Feet for 48266	89	A0889	Water Pipe for 48266	101	60932	Fan Guard for 48266	113
AL357	Castor for 48266	90	AL376	Circlip for 48266	102	60933	Fan Blade for 48266	114

# Parts Breakdown

**Model RS-CN-1050-B** 48269

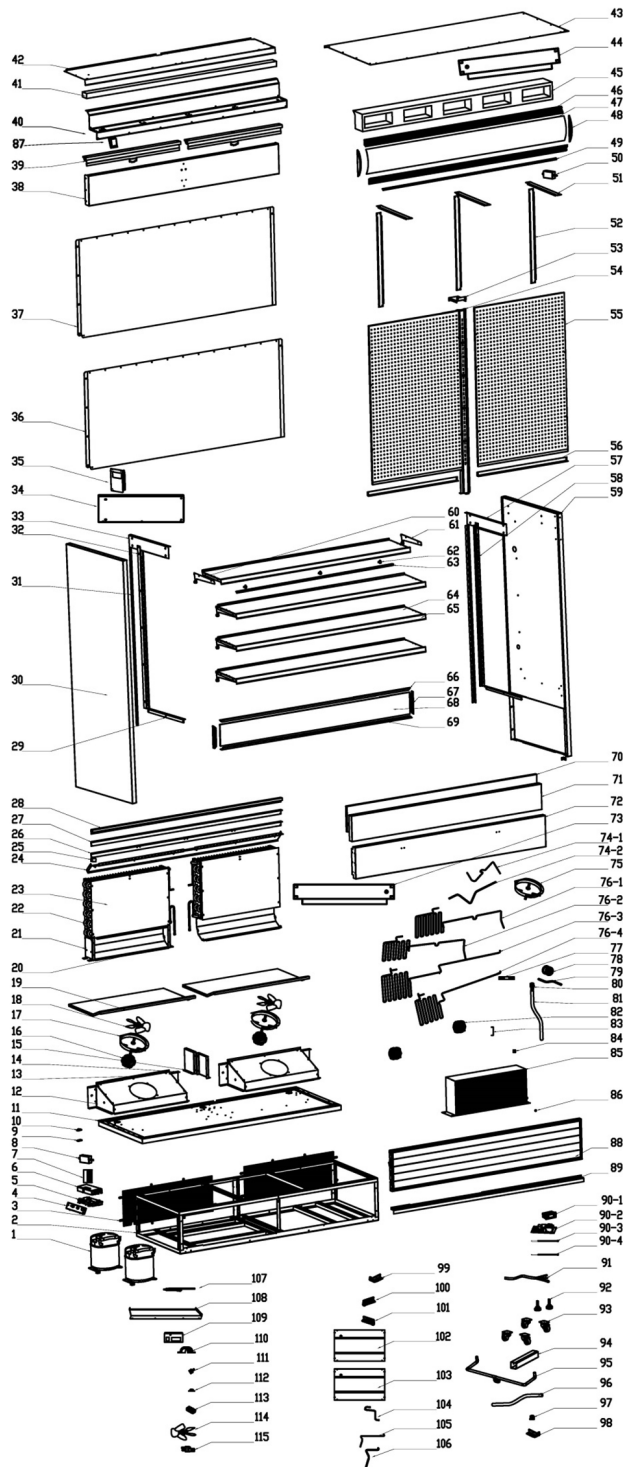

# Parts Breakdown

## Model RS-CN-1050-B 48269

Item No.	Description	Position	Item No.	Description	Position	Item No.	Description	Position
AP414	Compressor (R290) for 48269	1	67676	Crosspiece of Back Foam for 48269	26	67684	Vertical Plate of Back Foam for 48269	52
AP434	Base for 48269	2	66105	Back Upper Crosspiece for 48269	27	60686	Holding Plate of Back Foam Crosspiece for 48269	53
60599	Mesh Guard in Base for 48269	3	67677	Thicker Crosspiece of Back Ventilated Board for 48269	28	AQ695	Middle Support Pillar of Shelf for 48269	54
A0860	Wiring Box for 48269	4	60610	Parry of Lower Air Intake for 48269	29	AQ696	Ventilated Board for 48269	55
61167	Circuit Board Box for 48269	5	AQ661	Left Side Board for 48269	30	60703	Back Support for Board at Air Intake for 48269	56
60594	Cover of Circuit Board Box for 48269	6	60613	Dead Plate of Rear Foam for 48269	31	60629	Parry of Right Lining Plate for 48269	57
A0861	Cap of Juncting Box for 48269	7	AQ662	Left Support Pillar of Shelf for 48269	32	AQ669	Right Support Pillar of Shelf for 48269	58
A0862	LED Transformer for 48269	8, 50	60615	Parry of Right Lining Plate for 48269	33	AQ670	Right Side Board for 48269	59
60676	Wire Clip Holder for 48269	9	AP435	Right Windshield of Condenser for 48269	34	A0905	Left/Right Support Pillar of Shelf for 48269	60, 61
60677	Wire Clip Cover for 48269	10	AP436	Left Windshield of Condenser for 48269	35	AP437	Jump Ring of LED Light for 48269	62
60679	Foam of Base Plate for 48269	11	AQ689	Lower Back Plate for 48269	36	A0924	LED for 48269	63
60680	Left Board of Evaporator Cover for 48269	12	AQ690	Upper Back Plate for 48269	37	AP438	General Assembly for Shelves for 48269	64
60603	Evaporator Cover for 48269	13	AQ691	Upper Front Board for 48269	38	60709	Price Tag Holder for 48269	65
60681	Left Plate of Evaporator Motor for 48269	14	60692	Night Curtain for 48269	39	60712	Decorating Strip of Glass Deflector for 48269	66
60684	Middle Support Pillar of Air Intake for 48269	15	AQ692	Damper of Upper Air Outlet for 48269	40	60710	Strip of Glass Deflector 2 for 48269	67
A0892	Evaporator Fan Motor for 48269	16	60694	Honeycomb Panel for 48269	41	67686	Glass Deflector for 48269	68
60932	Fan Guard for 48269	17	AQ693	Cover of Upper Air Outlet for 48269	42	60645	Strip of Glass Deflector for 48269	69
60640	Fan Blade for 48269	18	AQ694	Upper Cover Plate for 48269	43	60713	Lower Front Board Components for 48269	70
AQ688	Plate of Left/Right Air Intake for 48269	19	A0920	The Left of the Evaporator Water Box for 48269	44	60714	PE for Lower Board for 48269	71
60605	Evaporator Ventilation Damper for 48269	20	60698	Lining Foam for 48269	45	AQ697	Lower Front Board for 48269	72
60604	Evaporator Holder for 48269	21	60700	Lampshade Frame for 48269	46	A0927	The Right Side of the Evaporator Water Box for 48269	73
A0864	Evaporator for 48269	22	60701	Lampshade for 48269	47	AP439	Right Joint Pipe of Compressor for 48269	74-1
60607	Evaporator Damper for 48269	23	60628	Holder of Lampshade Frame for 48269	48	AP440	Left Joint Pipe of Compressor for 48269	74-2
60683	Evaporator Wind Screen for 48269	24	A0921	LED in Light Box for 48269	49	60641	Fan Guard for 48269	75
A0912	Shock-Absorbing Parts for 48269	25	60696	Vertical Plate of Upper Foam for 48269	51	AP441	Right Bottom High Pressure Evaporating Tube for 48269	76-1

# Parts Breakdown

## Model RS-CN-1050-B 48269

Item No.	Description	Position	Item No.	Description	Position	Item No.	Description	Position
AP442	Left Bottom High Pressure Evaporating Tube for 48269	76-2	AQ699	Lower Front Crosspiece for 48269	89	AP448	Left Front Bracket of Evaporating Pan for 48269	101
AP443	Right Top High Pressure Evaporating Tube for 48269	76-3	67648	Temperature Display for 48269	90-1	AP449	Bottom Evaporating Pan Assembly for 48269	102
AP444	Left Top High Pressure Evaporating Tube for 48269	76-4	AP424	Main Circuit Board for 48269	90-2	AP450	Top Evaporating Pan Assembly for 48269	103
A0929	The Bracket on the Water Pipe for 48269	77	A0934	Temperature Probe for 48269	90-3	AP451	High Pressure Evaporation Connect Tube for 48269	104
70106	Dry Filter for 48269	78	A0887	Defrost Probe for 48269	90-4	AP452	Connecting Tube for Right Condenser and Dry Filter for 48269	105
AP422	Joint Pipe of Dry Filter for 48269	79	AC057	Power Cord for 48269	91	AP453	Connecting Tube for Left Condenser and Dry Filter for 48269	106
A0930	Drain Joint for 48269	80	60672	Feet for 48269	92	AP429	Tee Joint for 48269	107
A0931	Drain Pipe for 48269	81	AL357	Castor for 48269	93	AP454	Top Baffle Board of Condenser for 48269	108
70111	Fan Motor for 48269	82	60590	PVC Trucking for 48269	94	AP403	Switch Display Bracket for 48269	109
A0932	Under-Wear Pipe Bracket for 48269	83	A0888	PVC Pipe for 48269	95	A0865	Filter Pressure Plate for 48269	110
60633	Side Plate Connector for 48269	84	60668	Drain Pipe for 48269	96	68398	Copper Connection for 48269	111
AP423	Condenser for 48269	85	60670	PPR Tube Strap for 48269	97	60669	Pressing Plate of Dry Filter for 48269	112
68301	Strong Magnet for 48269	86	AP445	Right Rear Bracket of Evaporating Pan for 48269	98	AP432	Wago Wire Connector for 48269	113
AR485	Switch (Higher Amp) for 48269	87	AP446	Right Front Bracket of Evaporating Pan for 48269	99	60933	Fan Blade for 48269	114
AQ698	Window Shutter for 48269	88	AP447	Left Rear Bracket of Evaporating Pan for 48269	100	AP433	American Plug for 48269	115

# Electrical Schematics

**Model RS-CN-0440** 48479

**Model RS-CN-0440-B** 48480

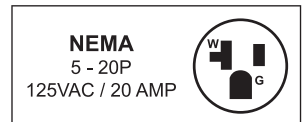
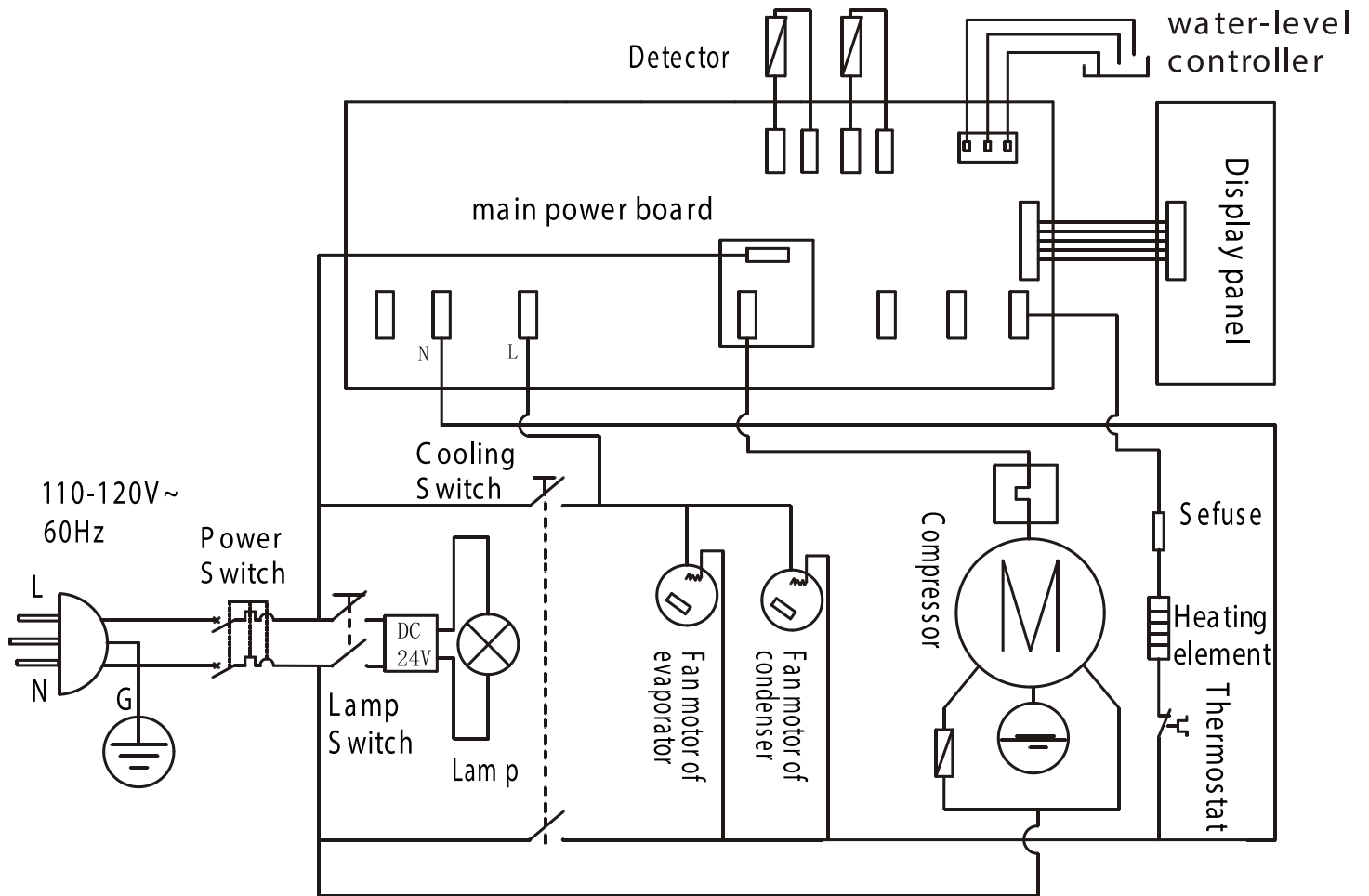

# Electrical Schematics

**Model RS-CN-0530** 43459

**Model RS-CN-0530-B** 48265

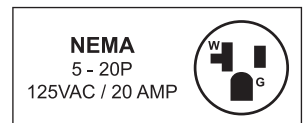
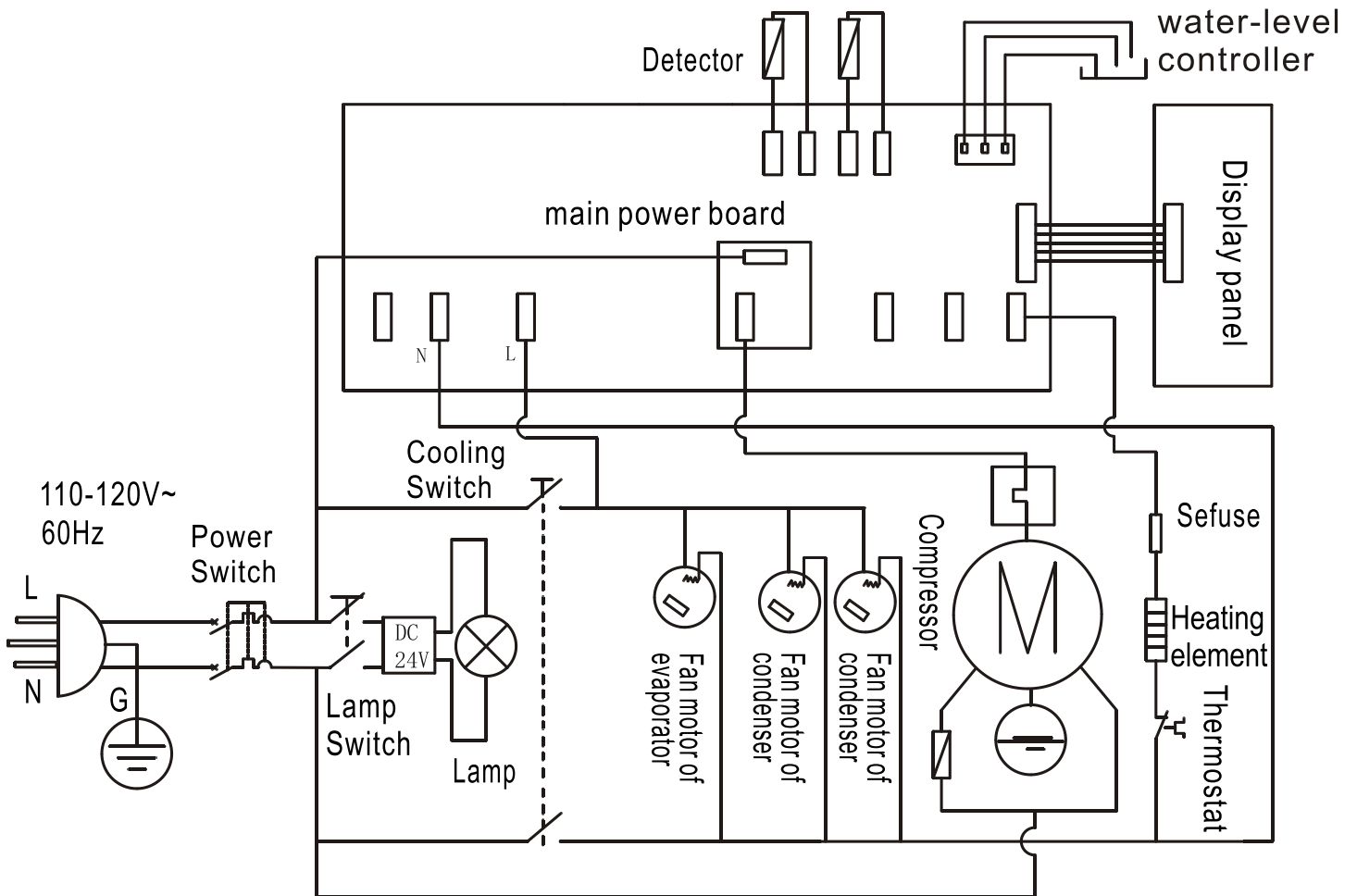

# Electrical Schematics

**Model RS-CN-0700** 41469

**Model RS-CN-0700-B** 48266

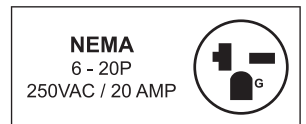
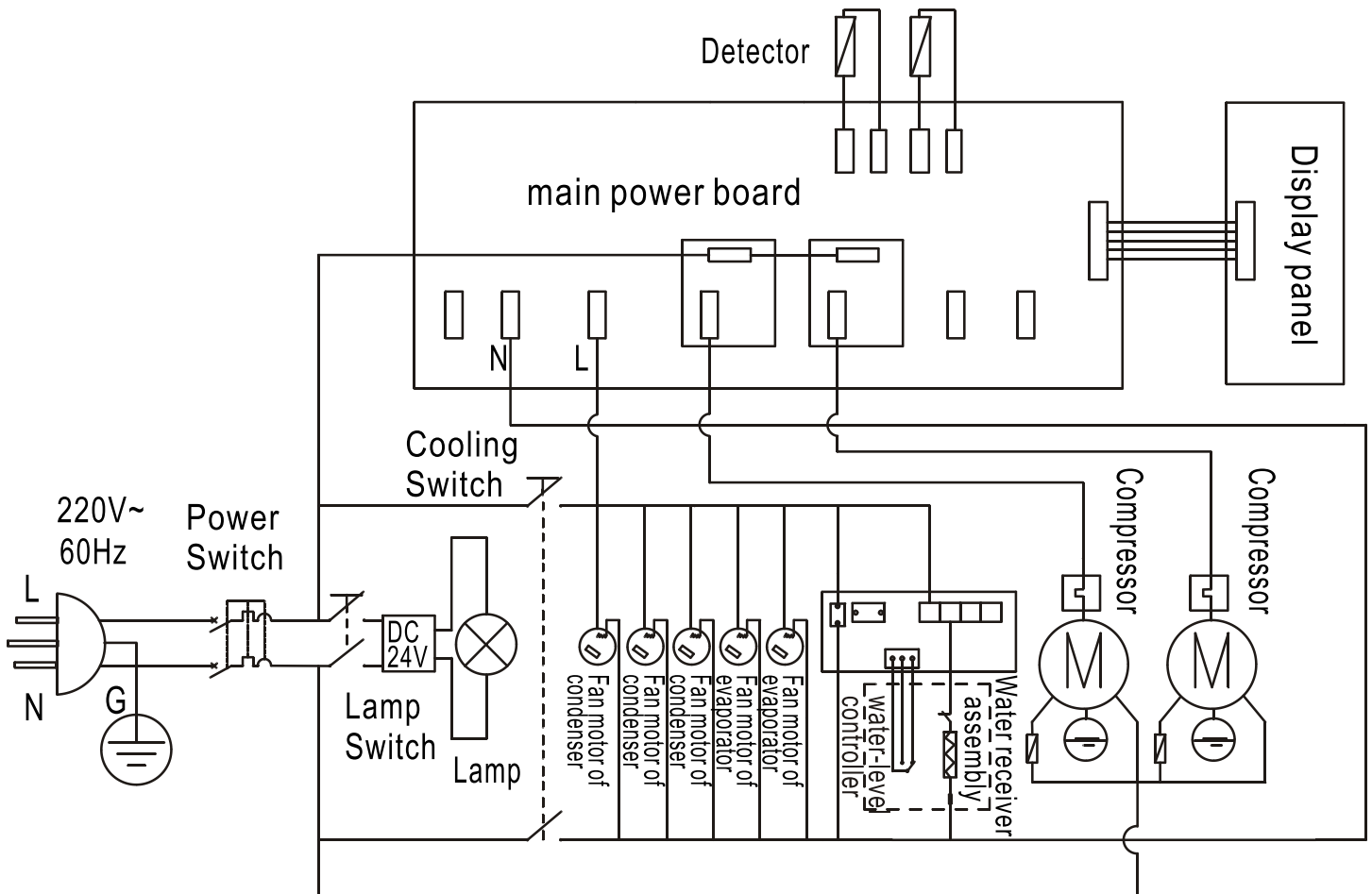











# Warranty Registration

Thank you for purchasing an Omcan product. To register your warranty for this product, complete the information below, tear off the card at the perforation and then send to the address specified below. You can also register online by visiting:

Merci d'avoir acheté un produit Omcan. Pour enregistrer votre garantie pour ce produit, complétez les informations ci-dessous, détachez la carte au niveau de la perforation, puis l'envoyer à l'adresse spécifiée ci-dessous. Vous pouvez également vous inscrire en ligne en visitant:

Gracias por comprar un producto Omcan usted. Para registrar su garantía para este producto, complete la información a continuación, cortar la tarjeta en la perforación y luego enviarlo a la dirección indicada a continuación. También puede registrarse en línea en:

<https://omcan.com/warranty-registration/>

For mailing in Canada

Pour postale au Canada

Por correo en Canadá

**OMCAN**

PRODUCT WARRANTY REGISTRATION

3115 Pepper Mill Court,  
Mississauga, Ontario  
Canada, L5L 4X5

For mailing in the US

Pour diffusion aux États-Unis

Por correo en los EE.UU.

**OMCAN**

PRODUCT WARRANTY REGISTRATION

4450 Witmer Industrial Estates, Unit 4,  
Niagara Falls, New York  
USA, 14305

*or email to: [service@omcan.com](mailto:service@omcan.com)*



Purchaser's Information

Name: \_\_\_\_\_

Address: \_\_\_\_\_

City: \_\_\_\_\_ Province or State: \_\_\_\_\_ Postal or Zip: \_\_\_\_\_

Country: \_\_\_\_\_

Dealer from which Purchased: \_\_\_\_\_

Dealer City: \_\_\_\_\_ Dealer Province or State: \_\_\_\_\_

Invoice: \_\_\_\_\_

Model Name: \_\_\_\_\_ Model Number: \_\_\_\_\_

Machine Description: \_\_\_\_\_

Date of Purchase (MM/DD/YYYY): \_\_\_\_\_

Would you like to extend the warranty?  Yes  No

Company Name: \_\_\_\_\_

Telephone: \_\_\_\_\_

Email Address: \_\_\_\_\_

Type of Company:

Restaurant  Bakery  Deli

Butcher  Supermarket  Caterer

Institution (specify): \_\_\_\_\_

Other (specify): \_\_\_\_\_

Serial Number: \_\_\_\_\_

Date of Installation (MM/DD/YYYY): \_\_\_\_\_

**Thank you for choosing Omcan | Merci d'avoir choisi Omcan | Gracias por elegir Omcan**



Since 1951 Omcan has grown to become a leading distributor of equipment and supplies to the North American food service industry. Our success over these many years can be attributed to our commitment to strengthen and develop new and existing relationships with our valued customers and manufacturers. Today with partners in North America, Europe, Asia and South America, we continually work to improve and grow the company. We strive to offer customers exceptional value through our qualified local sales and service representatives who provide convenient access to over 6,500 globally sourced products.

---

Depuis 1951 Omcan a grandi pour devenir un des "leaders" de la distribution des équipements et matériel pour l'industrie des services alimentaires en Amérique du Nord. Notre succès au cours de ces nombreuses années peut être attribué à notre engagement à renforcer et à développer de nouvelles et existantes relations avec nos clients et les fabricants de valeur. Aujourd'hui avec des partenaires en Amérique du Nord, Europe, Asie et Amérique du Sud, nous travaillons continuellement à améliorer et développer l'entreprise. Nous nous efforçons d'offrir à nos clients une valeur exceptionnelle grâce à nos ventes locales qualifiées et des représentants de service qui offrent un accès facile à plus de 6500 produits provenant du monde entier.

---

Desde 1951 Omcan ha crecido hasta convertirse en un líder en la distribución de equipos y suministros de alimentos en América del Norte industria de servicios. Nuestro éxito en estos años se puede atribuir a nuestro compromiso de fortalecer y desarrollar nuevas relaciones existentes con nuestros valiosos clientes y fabricantes. Hoy con socios de América del Norte, Europa, Asia y América del Sur, que trabajan continuamente para mejorar y crecer la empresa. Nos esforzamos por ofrecer a nuestros clientes valor excepcional a través de nuestro local de ventas y representantes de los servicios que proporcionan un fácil acceso a más de 6,500 productos con origen a nivel mundial.

