



BEVERAGE-AIR

Project: _____	AIA#
Item: _____	
Location: _____	SIS#
Approved: _____	

PRF24-24HC TOP MOUNT DUAL TEMP REACH-IN

P SERIES TOP MOUNT DUAL TEMPERATURE
PRF24-24HC Solid Half-Door Refrigerator/Freezer
 Hydrocarbon Series

MODEL:
PRF24-24HC-1AHS



7 Year Parts/Labor Warranty
7 Year Compressor Warranty

CABINET CONSTRUCTION

- Stainless steel exterior door, sides, and front (galvanized top, back & bottom)
- Interior corrosion resistant aluminum
- Stainless steel door liner
- Full electronic control with exterior digital thermometer
- Expansion valve technology
- Variable speed technology
- Stainless steel breaker covers
- Dual temp refrigerator/freezer units provide two different operating temperature zones for different types of products
- Right section freezer
- Left section refrigerator
- Self-closing doors on cam-lift hinges, with 120° hold open feature
- One-piece snap-in magnetic door gaskets for positive seal
- Door locks standard
- Six (6) heavy-duty epoxy coated shelves
- 6" Legs

OPTIONS & ACCESSORIES

- Stainless steel back
- Stainless steel interior
- Additional shelves
- Zone operating temperature configuration (R/R, F/R, F/F)
- Tray slide kit
- Left and right hand door swing (at time of order)
- 3" and 6" Casters
- Remote option* (see note on back page)

REFRIGERATION SYSTEM

- Uses environmentally friendly, energy efficient R290 refrigerant and meets all regulatory requirements for CARB, SNAP, DOE & more
- Adaptive defrost
- Epoxy coated evaporator coil
- Refrigerator maintains product temperatures of 36°-38°F
- Freezer maintains product temperatures of -10°F



Please verify qualifying units by visiting:
www.energystar.gov/cfs

3779 Champion Blvd., Win on-Salem, NC 27105
 1-888-845-9800 Fax: 1-336-245-6453
 Beverage-Air.com Sales@bevair.com



BEVERAGE-AIR

P Series Top Mount Dual Temp Reach-In Model: PRF24-24HC-1AHS

MODEL	PRF24-24HC-1AHS
EXTERNAL DIMENSIONAL DATA	
Width Overall	52 1/8"
Depth Overall with Handle	34 7/8"
Height Overall	84 1/8"
Number of Doors	4
Depth with Door Open 90°	57 1/2"
Door Openings (in)	21 1/2" x 25 1/4"
INTERNAL DIMENSIONAL DATA	
NET Capacity Refrigerator/Freezer (cubic ft.)	21.01 / 21.01
Internal Width Overall (in)	(2) 22 1/2"
Internal Depth Overall (in)	26"
Internal Height Overall (in)	56 5/8"
Number of Shelves	6
ELECTRICAL DATA	
Full Load Amperes** Refrigerator/Freezer	6.50 / 9.1
REFRIGERATION DATA	
Horsepower Refrigerator/Freezer	1/3 / 3/4
Capacity (BTU/Hr) Refrigerator/Freezer	5600 / 5600
Heat Rejection (BTU/Hr) Refrigerator/Freezer	8400 / 8400
Charge (lbs/grams/ounces) Refrigerator/Freezer	0.2866 / 130 / 4.6 0.3306 / 150 / 5.29
WEIGHT DATA	
Gross Weight - Crated lbs	692 lbs
Height - Crated	88"
Width - Crated	60"
Depth - Crated	45"

*NOTE: Remote units are field wired and come with 6" legs.
Refrigerant must be specified at time of order.

We reserve the right to change specifications and product design without notice. Such revisions do not entitle the buyer to corresponding changes, improvements, additions or replacements for previously purchased equipment. Dimensional tolerances +/- 1/4". Metric dimensions (MM).

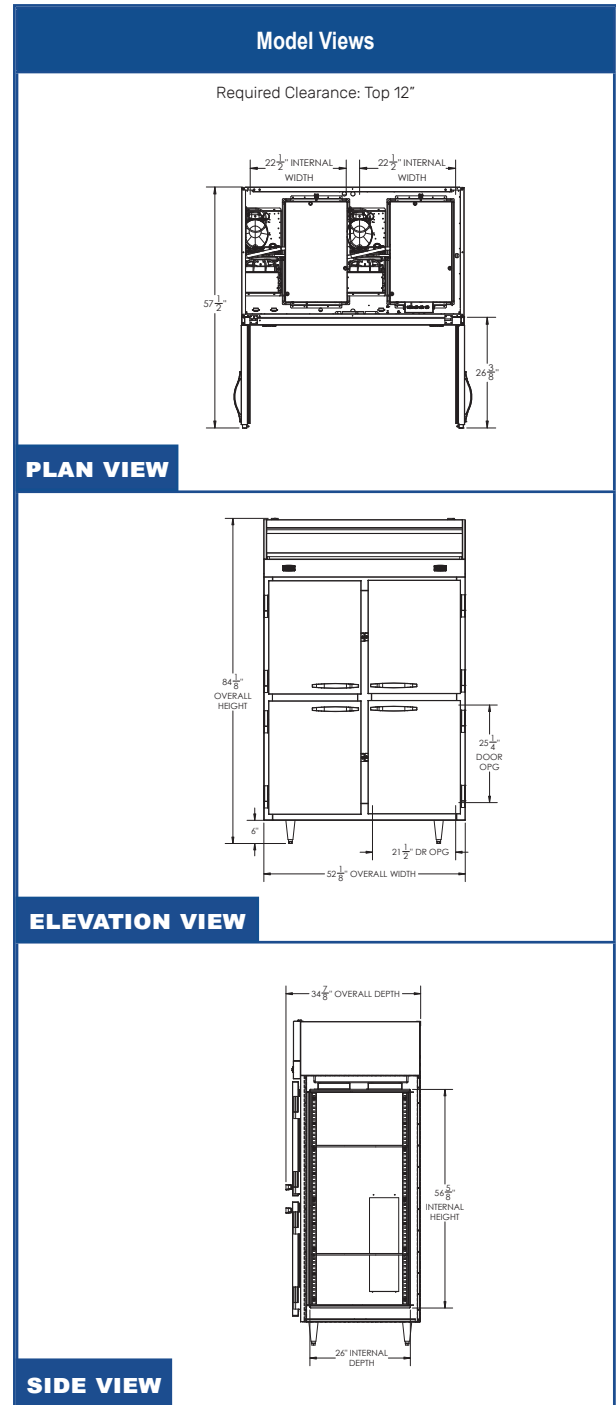

ELECTRICAL CONNECTION



(2) 115/60/1**
NEMA 5-15P

Unit pre-wired at factory
and include 8' long cord
and plug set.

** NOTE: Units that utilize variable speed compressor technology can experience nuisance tripping on Class A GFCI outlets which have a trip limit of 4 to 6 mA. To avoid this issue in a location that requires GFCI circuit protection, Beverage-Air recommends using either an Eaton, SCF20, or HUBBELL Model Number GFRST83W 20A Heavy Duty Hospital Grade Self-Test GFCI Receptacle.

