



YOU CAN TRUST

PLANETARY MIXERS

SMM10



STANDARD FEATURES

The SKYFOOD Planetary Mixer SMM10 is a great addition to any commercial kitchen looking for versatility with a minimal footprint. Designed for light to medium duty applications. Its 100% gear-driven transmission and overrated 3-speed 3/4 HP motor allow you to mix anything from whipped cream to cookie dough with confidence.

Includes stainless steel wire whip, cast aluminum dough beater and dough hook which can be selected to mix various kinds of foods.

For safety, this mixer is equipped with a bowl guard which stops the motor when opened or when the bowl is lowered.

The bowl and its removable safety guard are made of stainless steel.

Large start and stop push buttons are quickly accessible and make it easy to operate the mixer. This is a perfect compact countertop unit to complement your essential kitchen tools.

Conforms to the following Standards:
ETL electrical and sanitation (under UL, CSA and NSF Standards).



SMM10
10 qt Planetary Mixer

ILLUSTRATIVE PHOTO, ACTUAL PRODUCTS AND ACCESSORIES ARE SUBJECT TO CHANGE WITHOUT NOTICE.



Skyfood Equipment LLC
175 SW 7th Street, Ste 2416
Miami, FL 33130 - 2992

Toll Free:
1-800-503-7534
sales@skyfood.us

www.skyfood.us



Follow us to keep up to date with the latest news and offers

/SkyfoodEquipment

/SkyfoodEquipment

/SkyfoodEquipment



YOU CAN TRUST

PLANETARY MIXERS

SMM10



DIMENSIONS

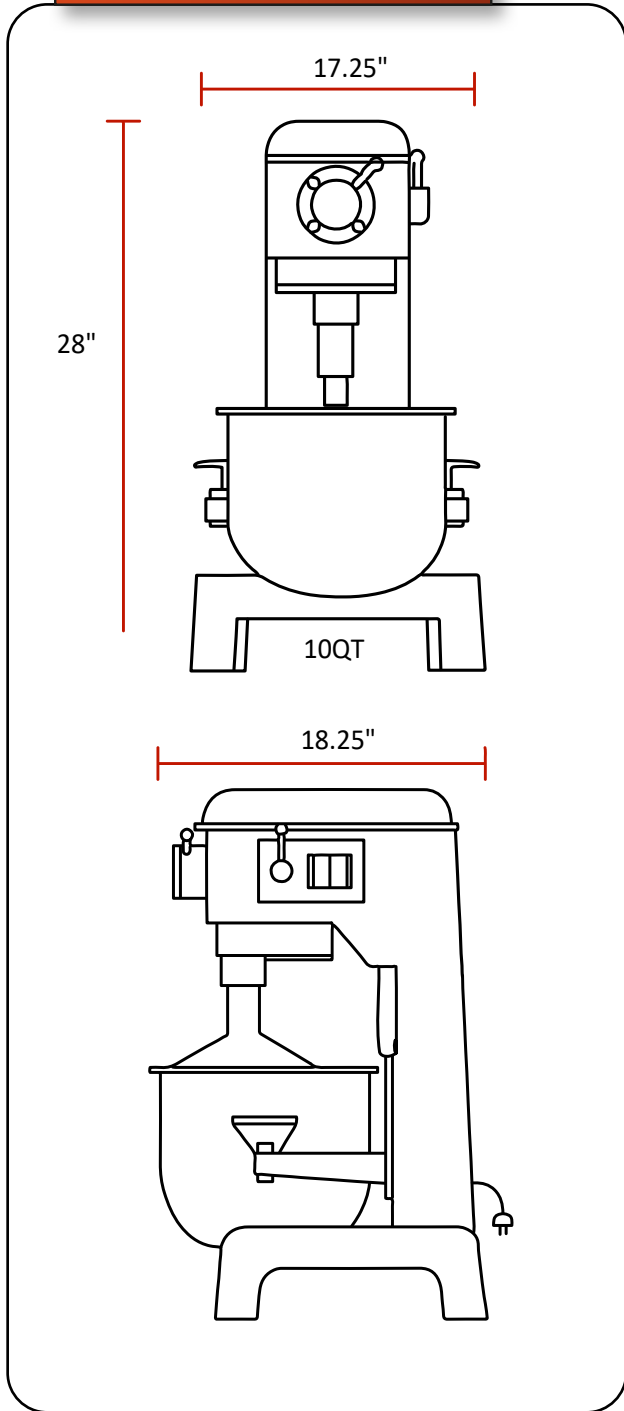

ATTACHMENTS



OPERATION:

- Powerful motor
- Direct drive 100% gear driven transmission for consistent mixing speed
- Three fixed speeds
- Push button On/Off Switch

CONSTRUCTION:

- Heavy duty construction
- Stainless steel wire safety guard around bowl
- Stainless steel bowl clamps hold mixing bowl securely in place
- Rubber inserts on feet for stability

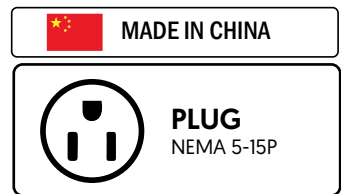

WARRANTY 01 YEAR PARTS AND LABOR VALID IN THE CONTINENTAL UNITED STATES.

Item	Power Rating	Amps	Dimensions (W x D x H)	Shipping Dimensions (W x D x H)	Weight (Net x Ship)	Bowl Capacity	Max. Dough Capacity	RPM	PLUG
SMM10	3/4 HP (600 W)	5	17.25" x 18.25" x 28 "	20" x 22" x 29"	123 lb x 150 lb	10 qt	4.5 lb	113/184/341	NEMA 5-15P

ILLUSTRATIVE PHOTO. ACTUAL PRODUCTS AND ACCESSORIES ARE SUBJECT TO CHANGE WITHOUT NOTICE.



Skyfood Equipment LLC
175 SW 7th Street, Ste 2416
Miami, FL 33130

Toll Free:
1-800-503-7534
sales@skyfood.us

www.skyfood.us



Follow us to keep up to date with the latest news and offers

[/SkyfoodEquipment](#)

[/SkyfoodEquipment](#)

[/SkyfoodEquipment](#)