

Merchandising Refrigerator 0.4

Technical Data Sheet

The Migali Merchandising Refrigerator 0.4 is the only small-scale commercial merchandising refrigerator that uses Phononic's solid-state technology to create and maintain consistent cooling. You won't be prohibited from selling products by the space or environmental constraints of traditional compressor-based refrigerators. Compact, modern and quiet, it allows you to feature impulse buys such as single-serve drinks and fresh snacks on checkout counters, bar tops and concession stands. With 0.4 cu. ft. internal capacity, the Migali Merchandising Refrigerator 0.4 fits perfectly within easy reach of you and your customers in grocery and convenience stores, restaurants, bars, hotels and stadiums.

With a Migali freezer, you can say goodbye to noisy, bulky and energy-hogging compressors and fans and hello to:

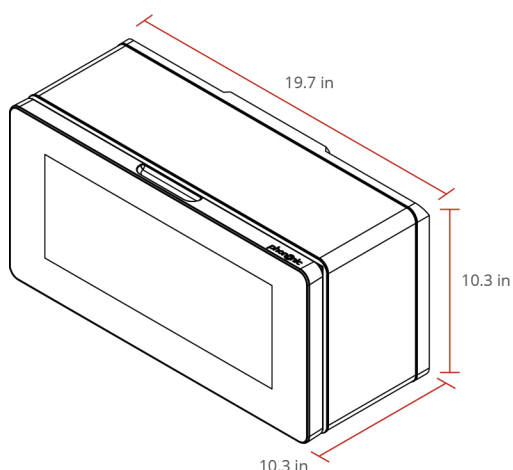

Features

- Solid-state refrigerator system delivering consistent performance at 2 °C
- Small form factor and low exhaust and vibration for optimal retail placement at the point of sale
- Easy-to-access angled slide door with balanced close mechanism
- Non-hazardous refrigerant
- Clear bin for inventory view
- Customizable look using personalized, interchangeable magnetic print images

Keep foods at the right temperature, in the right locations

Compressor-free cooling is setting new standards in capacity, reliability, efficiency, sustainability and security, so you can:



Sell more at the point of sale

Display the most profitable fresh products where they'll reach the most customers - not at perimeter walls, as is common today.



Deliver consistent cooling at lower cost

Fast recovery and optimal design keep food cold, even with frequent openings. Realize increased temperature stability and reduce total kWh.



Cut maintenance time and costs

Replace traditional refrigerators with long-lasting, reliable solid-state technology to spend less time and expense on maintenance.



Modernize countertop and consumer-facing displays

Aesthetic designs and near-silent operation looks great at point of sale and offers novel merchandising to meet consumer preferences.

Version 1009C

| Model | | Migali Merchandising Refrigerator 0.4 |
|-------------------|-----------------------------------|--|
| Basic Information | Materials | Painted Steel, Aluminum, Plastic, Tempered Glass |
| | Power Input | 100-240VAC 50Hz-60Hz (external brick, 170x85x33mm) |
| | Power Cord | 1.8 Meter, NEMA 5-15/CEE 7-7/BS 1363 Grade Plug |
| | Internal Lighting | Yes |
| Performance | Temperature Set-point | 3.3 °C |
| | Temperature Uniformity | < 3 °C |
| | Temperature Stability* | < 1 °C |
| | Noise Level | 39 dBA (steady-state) < 50 dBA (max) |
| | Energy Requirements | 1.3 kWh/day @ 24 °C Ambient |
| Safety | Rated Amps | 3.5 Amps |
| | Certifications | UL 471, FCC, Reach, RoHS, NSF-7 |
| Storage | Refrigerant | R744 (CO ₂) |
| | Internal Volume | 0.42 cubic feet |
| | Storage Bin | Clear Polycarbonate |
| Installation | Internal Dimensions | 16.9"W x 6.2"D x 7.0"H; 429mm W x 157mm D x 179mm H |
| | External Dimensions | 19.7"W x 10.7"D x 10.3"H; 500mm W x 271mm D x 262mm H |
| | Shipping Weight | 42 lbs |
| Warranty | Minimum Clearance Requirement | 50mm top/back |
| | Heat Pump | 10 years |
| | Full Refrigerator Parts and Labor | 1 year |

* Ambient range 10-32 °C, 40-70% RH, Elevation up to 2000M, Pollution Degree 2, IP3x

Version 1009C