



SERVING THE FOOD INDUSTRY SINCE 1951

Countertop Electric Hot Plates 2 Burners 4,000W 208V/60Hz/1ph

ITEM: 48556
MODEL: CE-CN-EHP15 208



Quick and Efficient Solution for Fast, Even Heating

Electric hot plate are a perfect addition to any food service operation.

2 kW round plate elements with easy-to-clean flat surface.

Provides a solid flat surface for fast, even heating.

Round plates are 9" (229) diameter for maximum pan contact.

Infinite heat controls for maximum cooking flexibility.

FEATURES:

- Heavy Duty Metal Knobs
- Incrementless Heat Adjustment
- Adjustable Stainless Steel Feet

Telephone: 1-800-465-0234

Fax: (905) 607-0234

Email: sales@omcan.com

Website: www.omcan.com



Authorized Dealer

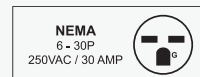

TECHNICAL DRAWING

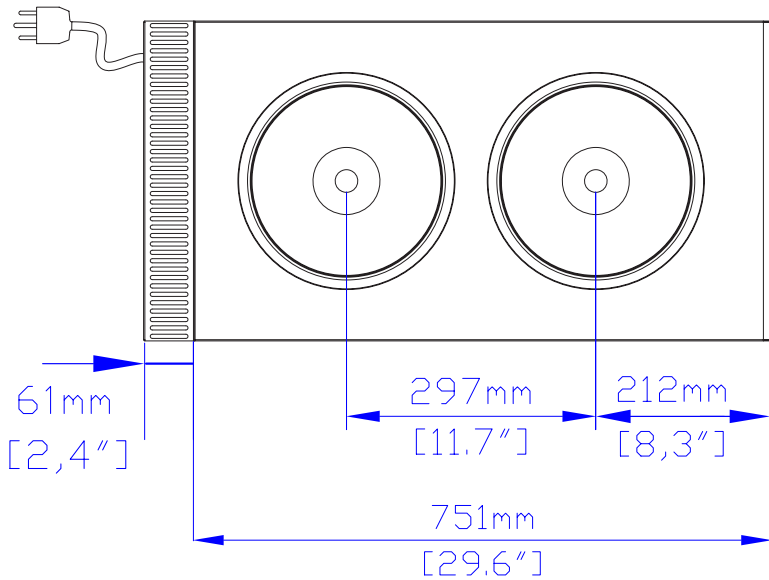

TECHNICAL SPECIFICATION

Item	48556
Model	CE-CN-EHP15 208
Power	4,000 W
Amperage	16.7 A
Electricals	208V / 60 Hz / 1ph
Net Dimensions	15" x 30" x 15" (381 x 762 x 1295 mm)
Gross Dimensions	19" x 35" x 20" (483 x 889 x 508 mm)
Net Weight	48 lb. (21.7 kg.)
Gross Weight	71 lb. (32.2 kg.)

BMAD System (Low maintenance high performance). Dimensions rounded up to the nearest inch or millimeter. Specifications subject to change without notice.

