



Project Name: _____

Location: _____

Item #: _____

Qty: _____

Grista Energy Star Reach-in Freezer, 2 Door - 48 Cu Ft, 54"

GRFZ-2DES



The Grista 2 Solid Door Reach-In Energy Star Freezer is crucial for restaurants, cafes, foodservice establishments and other commercial kitchens that require reliable frozen storage. This Energy Star-certified commercial reach-in freezer is designed with energy-efficient components to keep food and ingredients at safe, consistent temperatures, using environmentally friendly R290 refrigerant. The unit is constructed with an easy-to-clean 430 series stainless steel exterior and painted white aluminum interior. The storage capacity of 48 cubic feet (1359 L) is ideal for storing bulk frozen foods and ingredients.

FEATURES AND CONSTRUCTION

- Best-in-class, energy efficient design with Energy Star Certification
- Easy to clean 430 series stainless steel exterior and painted white aluminum interior
- Storage capacity of 48 cu ft (1359 L)
- Includes 6 epoxy coated corrosion resistant shelves with 90 lb capacity each
- Two self-closing solid doors with stay open feature beyond 90°
- Front digital temperature controller with LED display
- Incandescent interior lighting makes it easy to find and access stored items
- Digital temperature control range of -8°F to 0°F
- Bottom mounted condensing unit positioned for easy maintenance
- Preprogrammed digital control featuring auto defrost cycle
- Foamed in place insulation helps provide strength while helping to maintain internal temperature

ELECTRIC

115V / 60Hz / 1Ph
Cord Length (Inches): 98"
Plug Type: NEMA5-15P
Cord set included

NEMA 5-15P



3RD PARTY APPROVALS



WARRANTY (USA / CANADA)

2 Year Warranty on Parts & Labor
Contact Admiral Craft Equipment
for details at 1-877-672-7740



NOMINAL STORAGE CAPACITY

Cubic Feet: 46.7 cu. ft.

TEMPERATURE

Holding Temperature (Fahrenheit): -7° - 0°

These models are designed to operate in an environment



Grista Energy Star Reach-in Freezer, 2 Door - 48 Cu Ft, 54"

GRFZ-2DES

FRONT

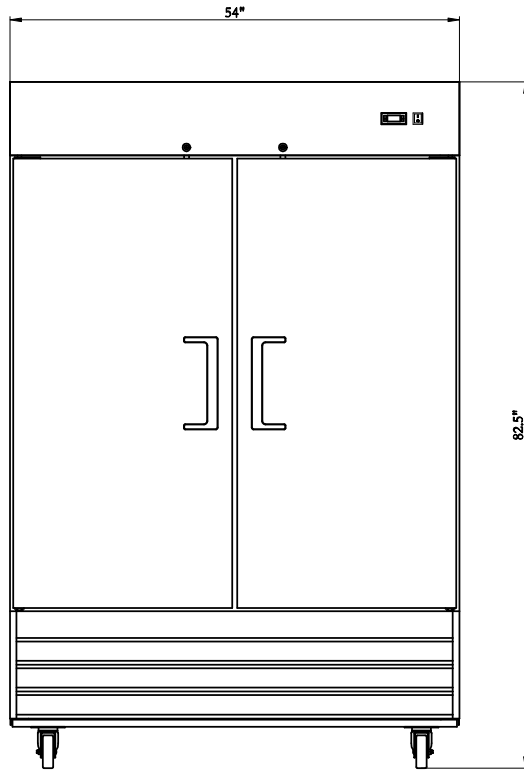

SIDE

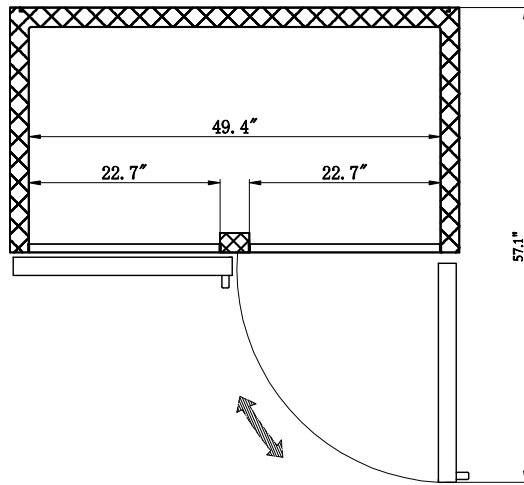
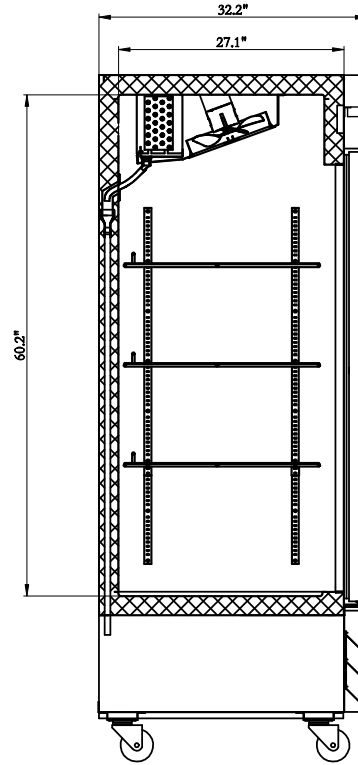

TOP

Reach-In Freezers

Doors	Shelves	Amps	HP	Refrigerant	Dimensions	Item Weight lbs	Shipping Weight lbs
2	6	7.8A	1	R290	54" x 32.2" x 82.5"	447.0	530.0

Due to periodic changes in designs, methods, procedures, policies and regulations, the specifications contained in this document are subject to change without notice. While we exercise good faith efforts to provide information that is accurate, we are not responsible for errors or omissions in information provided or conclusions reached as a result of using the specifications. By using the information provided, the user assumes all risks in connection with such use.