

SALAMANDER BROILER

GAS TYPE: NATURAL LP

■ ARSM-36

STANDARD FEATURES

- Heavy gauge insulated body
- All stainless steel front and sides
- Stainless steel pilot for instant ignition of burners
- 30,000 BTU/hr. burner provides instant, even heating
- Four level adjustable cooking grate
- Adjustable temperature
- Grate rolls out for ease of loading and unloading
- Large capacity grease tray
- Broiler grid can be easily removed for cleaning
- Two year limited warranty, parts, and labor

OPTIONAL FEATURES

- Mounting assemblies available for wall mounting
- Mounting assemblies available for range-mounting



Model Shown ARSM-36

DESCRIPTION

American Range, Salamander Broiler ARSM-36" unit has 30,000 BTU/hr. infrared adjustable burners. Four level adjustable cooking grate. Grate rolls out for easy loading and unloading. Includes large capacity grease tray and stainless steel front and sides.



SALAMANDER BROILER

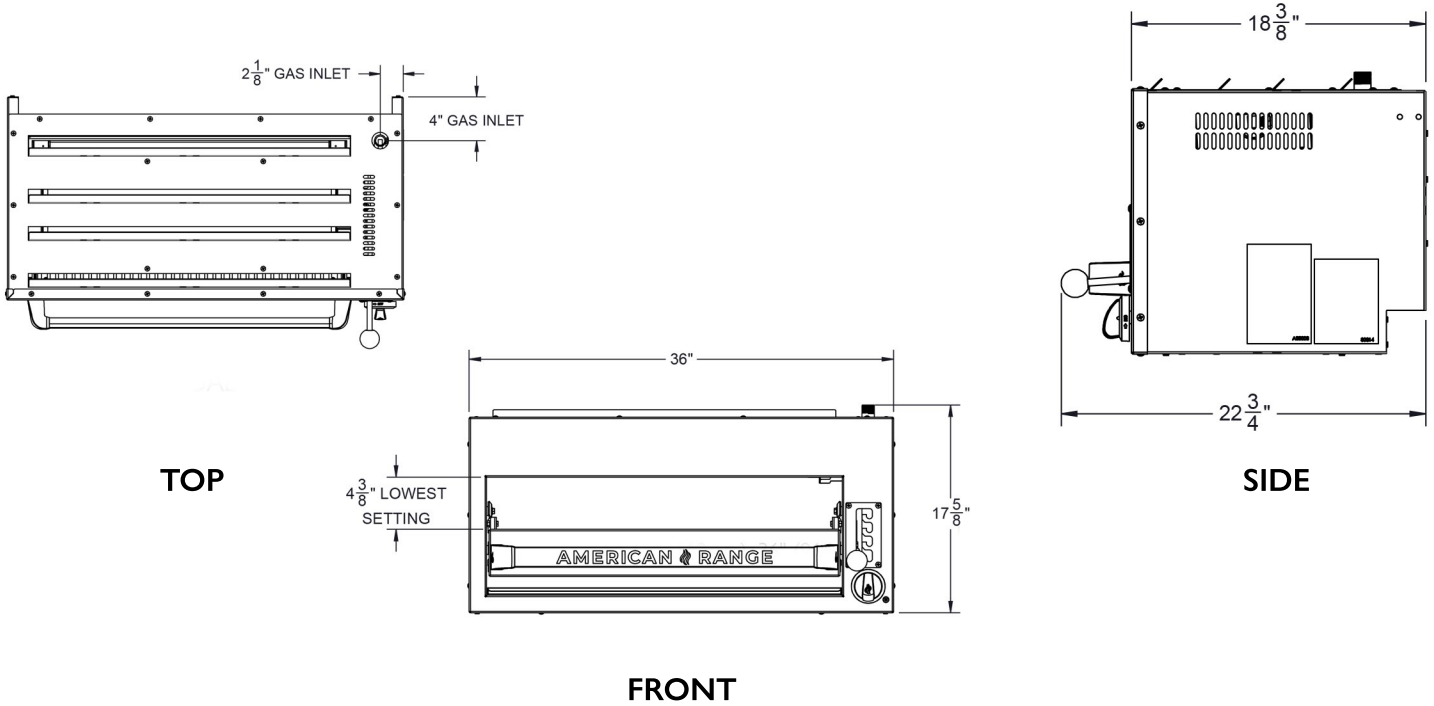

ARSM-36 36" SINGLE CONTROL SALAMANDER BROILER

Model	Width (mm)	Depth (mm)	Height (mm)	Burners	BTU/hr.	(kW)	Shipping Weight*	
							Lbs	(kg)
ARSM-36	36" (914)	18" (458)	21 1/2" (547)	1	30,000	(9)	200	(91)

- Specify type of gas and altitude if over 2000 feet.
- Please specify gas type when ordering.

Standard mounting of ARSM is on the left side on larger size ranges.

CRATED DIMENSIONS (MM)
38"W x 20"D x 21"H (965 x 508 x 533)

*Shipping weight includes packaging and is approximate.

NATURAL GAS	MANIFOLD PRESSURE		MANIFOLD SIZE
	PROPANE GAS		
5.0" W.C.	10.0" W.C.		3/4" (19MM)

COMBUSTIBLE WALL CLEARANCES:

For use only on non-combustible floors. Legs or casters are required, or 2" (51) overhang is required when curb mounted. Clearance from non-combustible walls is 0". When unit is placed next to combustible walls, clearances must exceed 12" (305) from sides, and 4" (102) from rear. Radiant broilers for non-combustible locations only.

Commercial cooking equipment requires an adequate ventilation system. For additional information, refer to the National Fire Protection Association's standard, NFPA96 "Vapor Removal from Cooking Equipment." (NOTE: For North America only)

American Range is a quality manufacturer of commercial cooking equipment. Because of continuing product improvements these specifications are subject to change without prior notice.



A----- RevA 02252025



A HATCO COMPANY

13592 Desmond St Pacoima CA 91331
T. 818.897.0808 Toll Free: 888.753.9898
www.AmericanRange.com