



# BEVERAGE-AIR

Project: _____	AIA#
Item: _____	
Location: _____	SIS#
Approved: _____	

## HORIZON BOTTOM MOUNT REACH-IN

### HBF35HC Glass Door Reach-In Freezer

Hydrocarbon Series

**MODEL:**  
HBF35HC-1-G

**HBF35HC BOTTOM MOUNT REACH-IN FREEZER**



**7 Year Parts/Labor Warranty**  
**7 Year Compressor Warranty**

#### CABINET CONSTRUCTION

- Stainless steel front, side, and grille (galvanized back & bottom)
- Stainless steel interior
- Full electronic control with one-touch defrost
- One-piece grille allow easy removal/installation for preventative maintenance
- Self closing door with 120° stay open feature
- LED lighting
- Spring-loaded style hinges
- Plug-in magnetic door gaskets
- Six (6) heavy duty epoxy coated wire shelves
- 6" Casters with two (2) brakes

#### OPTIONS & ACCESSORIES

- 3" Casters or 6" legs
- Epoxy shelves
- Door locks
- Shelf clips
- Remote option\* (see note on back page)

#### REFRIGERATION SYSTEM

- Uses environmentally friendly, energy efficient R290 refrigerant, and meets all regulatory requirements for CARB, SNAP, DOE & more
- Hot gas condensate evaporator
- Adaptive defrost
- Epoxy coated evaporator coil
- Freezer capable of maintaining product temperature down to -10°F



 Please verify qualifying units by visiting:  
[www.energystar.gov/cfs](http://www.energystar.gov/cfs)

3779 Champion Blvd., Winston-Salem, NC 27105  
1-888-845-9800 Fax: 1-336-245-6453  
Beverage-Air.com Sales@bevair.com



# BEVERAGE-AIR

MODEL	HBF35HC-1-G
<b>EXTERNAL DIMENSIONAL DATA</b>	
Width Overall	39 1/2"
Depth Overall with Handle	33 1/2"
Height Overall with Casters	84"
Number of Doors	2
Depth with Door Open 90°	49 3/4"
Door Openings (in)	16 1/2" x 52 3/4"
<b>INTERNAL DIMENSIONAL DATA</b>	
NET Capacity (cubic ft.)	35.082
Internal Width Overall (in)	36 1/2"
Internal Depth Overall (in)	28 1/4"
Internal Height Overall (in)	61 3/4"
Internal Height Useable (in)	55"
Number of Shelves	6
<b>ELECTRICAL DATA</b>	
Full Load Amperes	10.0
Voltage	115/60/1
Nema Plug (8' cord)	5-15P
<b>REFRIGERATION DATA</b>	
Horsepower	3/4
Capacity (BTU/Hr)	2772
Heat Rejection (BTU/Hr)	4158
Charge (lbs/grams/ounces)	0.2204 / 100 / 3.5
<b>SHIPPING DATA</b>	
Gross Weight - Crated	562 lbs
Height - Crated	86"
Width - Crated	49"
Depth - Crated	36"

\*NOTE: Remote units are field wired and come with 6" legs. Refrigerant must be specified at time of order.

We reserve the right to change specifications and product design without notice. Such revisions do not entitle the buyer to corresponding changes, improvements, additions or replacements for previously purchased equipment. Dimensional tolerances +/- 1/4". Metric dimensions (MM).

## Bottom Mount Reach-In Freezer Model: HBF35HC-1-G

### Model Views

Required Clearance: Bottom & Rear 3"

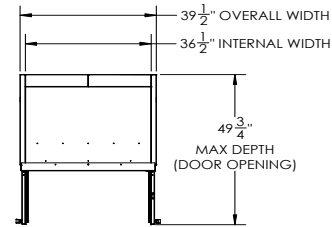

### PLAN VIEW

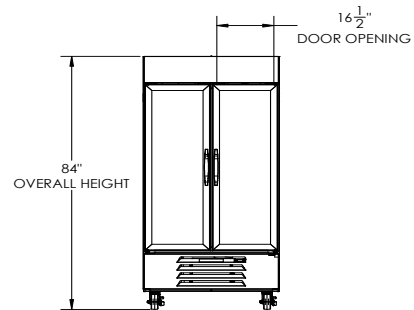

### ELEVATION VIEW

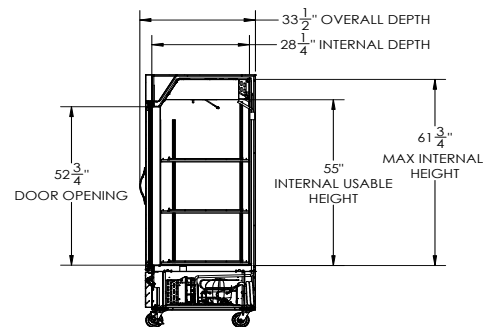

### SIDE VIEW

### ELECTRICAL CONNECTION



115/60/1  
NEMA 5-15P

Unit pre-wired at factory and include 8' long cord and plug set.

