

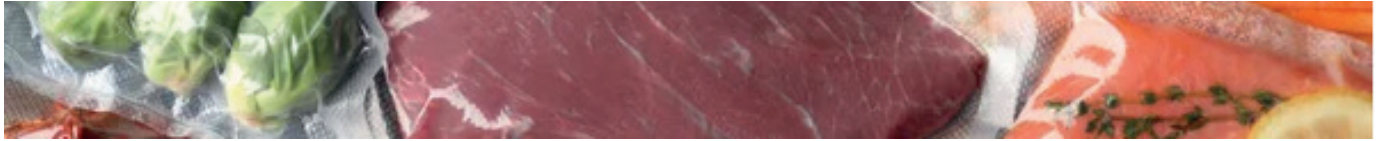

YOU CAN TRUST

SEALING MACHINES

IBS-200 / IBS-300 / IBS-400 / IBS-500



STANDARD FEATURES

Skyfood Impulse Bag Sealers are available in different sizes, 8, 12, 16 and 20" long seal bar to better suit your needs. Compact yet robust construction, these portable bag sealers are essential tools in any food service and other commercial operations.

Sealing food products helps protect them from getting stale or rotten, avoiding waste and increasing profit for your business. Ready to use, our Bag Sealers require no warm up time. Adjustable timer creates perfect seals for bags up to 8 mil thick. For use with PP (polypropylene) and PE (polyethylene) bags.

- Instantly use, no warm up time needed
- 7 timer settings to seal bags up to 8 mil thick
- Seal PP (polypropylene) and PE (polyethylene) bags
- On and Timer light indicators
- Lightweight design and portable
- Easy to use and to clean
- Service kit available



IBS-200
8" IMPULSE BAG SEALER



IBS-300
12" IMPULSE BAG SEALER



IBS-400
16" IMPULSE BAG SEALER



IBS-500
20" IMPULSE BAG SEALER



ILLUSTRATIVE PHOTO, ACTUAL PRODUCTS AND ACCESSORIES ARE SUBJECT TO CHANGE WITHOUT NOTICE.



Skyfood Equipment LLC
175 SW 7th Street, Ste 2416
Miami, FL 33130

Toll Free:
1-800-503-7534
sales@skyfood.us

www.skyfood.us



Follow us to keep up to date with the latest news and offers

/SkyfoodEquipment

/SkyfoodEquipment

/SkyfoodEquipment



DIMENSIONS / IBS-200

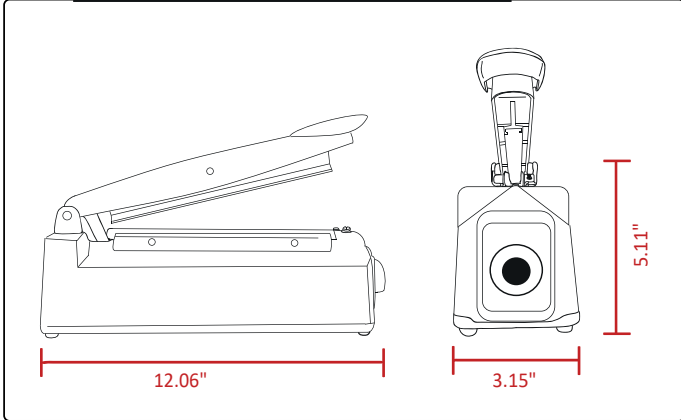

DIMENSIONS / IBS-300

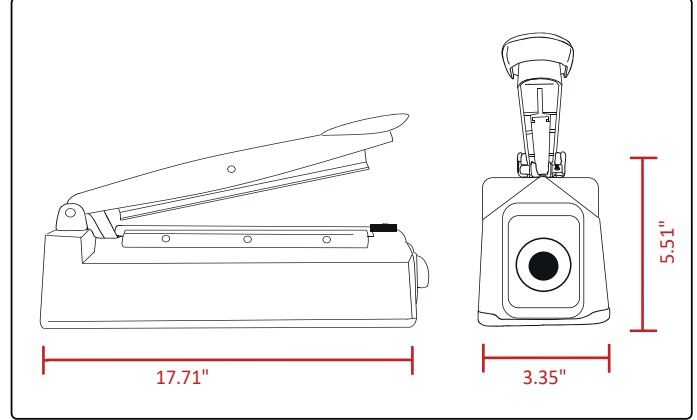

DIMENSIONS / IBS-400

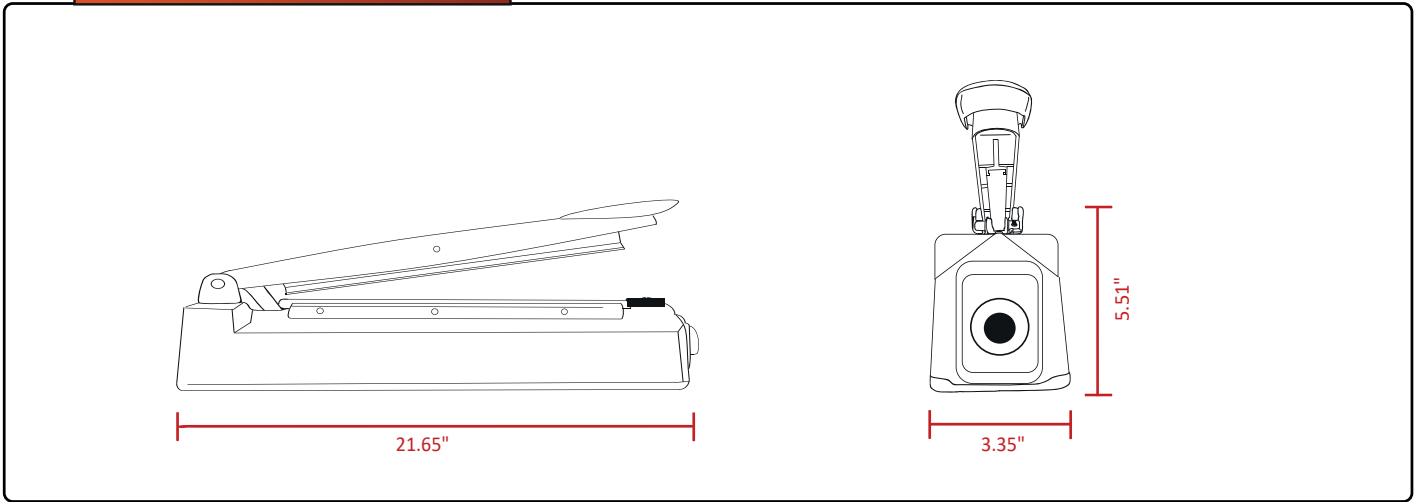

DIMENSIONS / IBS-500

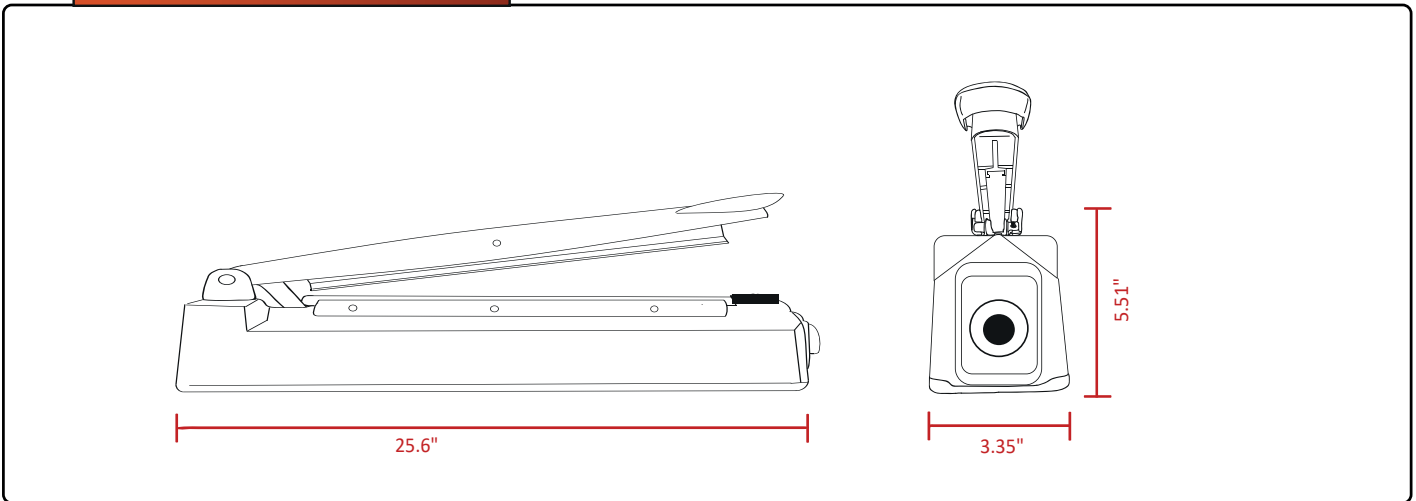

ILLUSTRATIVE PHOTO, ACTUAL PRODUCTS AND ACCESSORIES ARE SUBJECT TO CHANGE WITHOUT NOTICE.



Skyfood Equipment LLC
175 SW 7th Street, Ste 2416
Miami, FL 33130

Toll Free:
1-800-503-7534
sales@skyfood.us

www.skyfood.us



SEALING MACHINES

IBS-200 / IBS-300 / IBS-400 / IBS-500



CONTROL PANEL



HAND KNOB



SEALING BAR

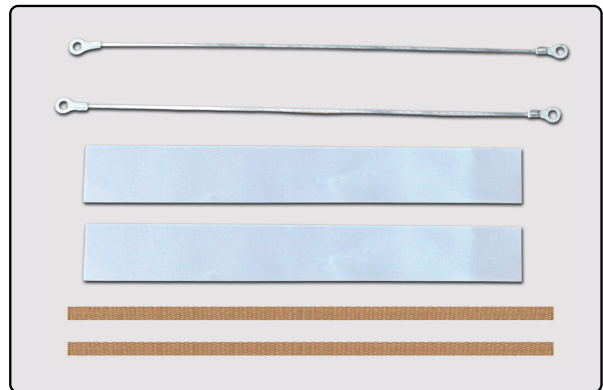

ELEMENT SERVICE KIT

INCLUDES

2 HEATING ELEMENTS

2 PTFE STRIPS

2 PTFE COVERS

WARRANTY 01 YEAR PARTS AND LABOR VALID IN THE CONTINENTAL UNITED STATES.



PLUG
NEMA 5-15P



MADE IN TAIWAN

Item	Voltage	Power Rating	Amps	Dimensions (W x D x H)	Weight (Net x Ship)	Seal Bar	Max. Bag Thickness	PLUG
IBS-200	110/220 V	280 W	2.5	3.15" x 12.6" x 5.11"	5.3 lb x 6 lb	7.8" long x 1/16" (1.6 mm) wide	8 MIL (0.2mm)	NEMA 5-15P
IBS-300	110/220 V	600 W	5.5	3.35" x 17.71" x 5.51"	10.4 lb x 11 lb	11.8" long x 1/16" (2 mm) wide	8 MIL (0.2mm)	NEMA 5-15P
IBS-400	110/220 V	620 W	5.6	3.35" x 21.65" x 5.51"	11 lb x 12 lb	15.7" long x 1/16" (2 mm) wide	8 MIL (0.2mm)	NEMA 5-15P
IBS-500	110/220 V	770 W	7	3.35" x 25.6" x 5.51"	14.1 lb x 15 lb	19.6" long x 1/16" (2 mm) wide	8 MIL (0.2mm)	NEMA 5-15P



Skyfood Equipment LLC
175 SW 7th Street, Ste 2416
Miami, FL 33130

Toll Free:
1-800-503-7534
sales@skyfood.us

www.skyfood.us

 AutoQuotes

 beedash

