

Merchandiser

17" SWING DOOR REFRIGERATOR



Black vinyl is the preferred finish for merchandisers as its more durable and doesn't chip versus a painted finish. Asber's merchandisers come with a chip resistant black vinyl exterior finish front, sides and back. Interior walls with NSF approved white coated steel finish to enhance its merchantability, easy to clean with a sturdy stainless-steel floor. Always one step above to ensure the upmost in safety and sanitation for your establishment.

Insulation in any Refrigerator is one of the most important factors for thermal efficiency. Asber only uses the **world's leader Ecomate (GWP) (ODP) insulation, 2" thick** for the highest R value efficiency for your environments.

With innovative and eco-friendly technology, Asber utilizes **R-290 Hydrocarbon** designed to meet DOE's Energy Conservation standards with very low contribution to global warming (ODP-0) (GWP-3).

LED interior lights offer shadow-free illumination, which lasts up to 10 times longer than fluorescent lights to enhance product display.

Double pane, hinged glass door refrigerator with argon gas insulation for enhance energy efficiency. Prevents heat transfers, minimizes condensation and provides a frost-free viewing environment.

Additional features to include:

- Hermetic compressors with epoxy coated evaporator
- Automatic evaporator: Paper fins not utilized in the evaporation process.
- Electronic controller with digital display
- Temperature: Refrigerators 32 °F to 38 °F, based on an external environment of 90 °F and 65% RH.
- Standard with adjustable feet.



ARM-17 A

OPTIONS & ACCESORIES

- Additional 2nd year warranty.
- 2.5" or 4" castors.
- Voltage: 220V. - 1 - 50Hz.
- Additional epoxy coated shelves.
- 6" adjustable stainless-steel legs.



MODEL	DOORS	SHELVES	CAPACITY (Cu. Ft.)	AMPS.	HP	VOLTS	DIMENSIONS			SHIPPING WEIGHT (lbs)
							Width	Depth	Height ¹	
ARM-17 A	1	4	16	2.2	1/4	115/60	27 1/8"	27 7/8"	73 7/8"	268

1. Height includes 1" leveler. 2. Specifications are subject to change without prior notice.

Merchandiser

17" SWING DOOR REFRIGERATOR



ARM-17 A FRONT

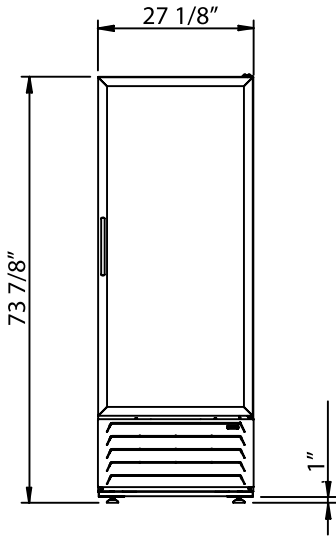

ARM-17 A TOP

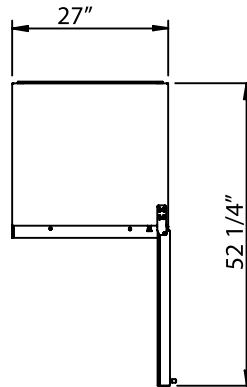

ARM-17 A SIDE

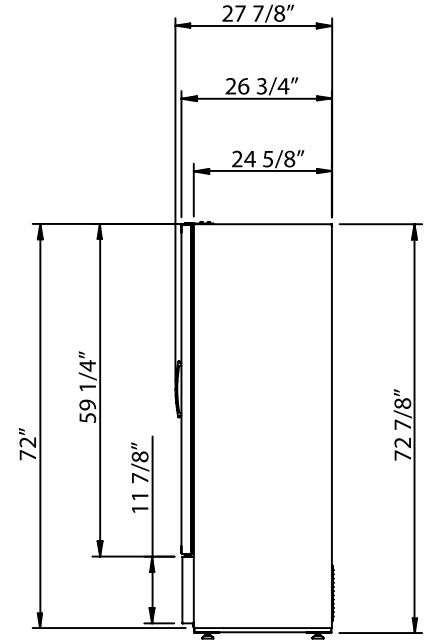

ELECTRICAL DATA		Refrigerator
Voltage		115/60
Plug Type		Nema 5-15P
Full Amp. Loads		2.2
Compressor HP		1/4
Cord Length (ft)		10
Refrigerant		R-290
DIMENSIONAL DATA		
# of Doors		1
Capacity (cu. ft.)		17
Ext. Width Overall		27 1/8"
Ext. Depth Overall		27 7/8"
Ext. Height Overall		73 7/8"
Int. Width Overall		23"
Int. Depth Overall		22 3/8"
Int. Height Overall		49 5/8"
# of Shelves - Std.		4
Shelf Size (L x D)		22 3/8" x 20 3/8"
Shipping Weight (lbs.)		268

Standard Features

- Black vinyl finish front, sides and back.
- 2" Ecomate CFC Free foam in place insulation.
- LED interior lights
- Electronic controller with digital display.
- Self-contained Refrigeration with epoxy coated evaporator.
- One-piece magnetic door gasket, removable without tools.

Options & Accesories Warranty

- Additional 2nd year warranty.
- 2.5" or 4" castors.
- Voltage: 220V. - I - 50Hz.
- Additional epoxy coated shelves.
- 6" adjustable stainless-steel legs.
- 1-year parts & labor.
- 5-year compressor.

*RESIDENTIAL APPLICATIONS: Asber assumes no liability for parts or labor coverage for component failure, factory defect or any other damages for units installed in non-commercial foodservice or residential applications.

1. Height includes 1" leveler.