

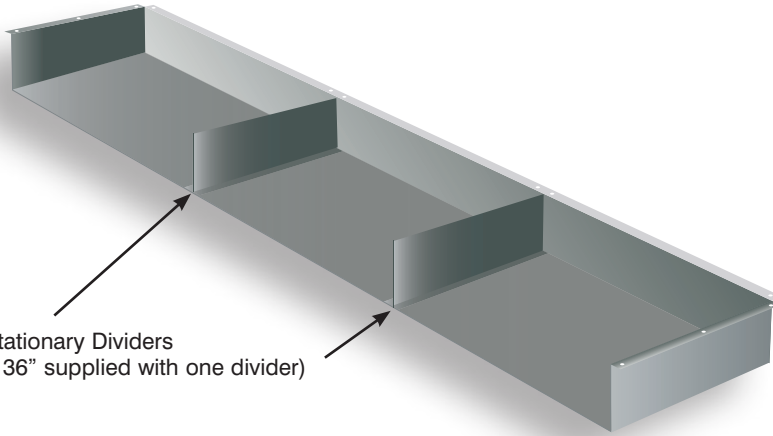

STAINLESS STEEL
**UNDER MOUNTED
 MULTI-PURPOSE SHELF**
 MODEL # TA-117



Item #: _____ Qty #: _____
 Model #: _____
 Project #: _____

Includes 2 Stationary Dividers
 (Units under 36" supplied with one divider)



FEATURES:

Includes two stationary dividers. Dividers are evenly spaced unless otherwise specified. (One divider for units under 36" in length). For additional dividers order **TA-117A**.

Factory installation only. Shelf area 1-1/2" less left to right and 3/4" less front to back than overall size (maximum front to back 18").

Supplied with mounting holes for field installation if desired.

CONSTRUCTION:

All TIG welded.

Dividers welded to shelf (not adjustable in field). Evenly spaced unless otherwise specified.

When used with Advance Tabco wall shelving the standard shelf brackets will be positioned during installation near ends and under dividers for maximum strength.

Safety "hem" along bottom edge of shelf.

Exposed surfaces polished to a satin finish.

MATERIAL:

18 gauge, 430 stainless steel.

DETAILS and SPECIFICATIONS

TOL ± .500"

ALL DIMENSIONS ARE TYPICAL

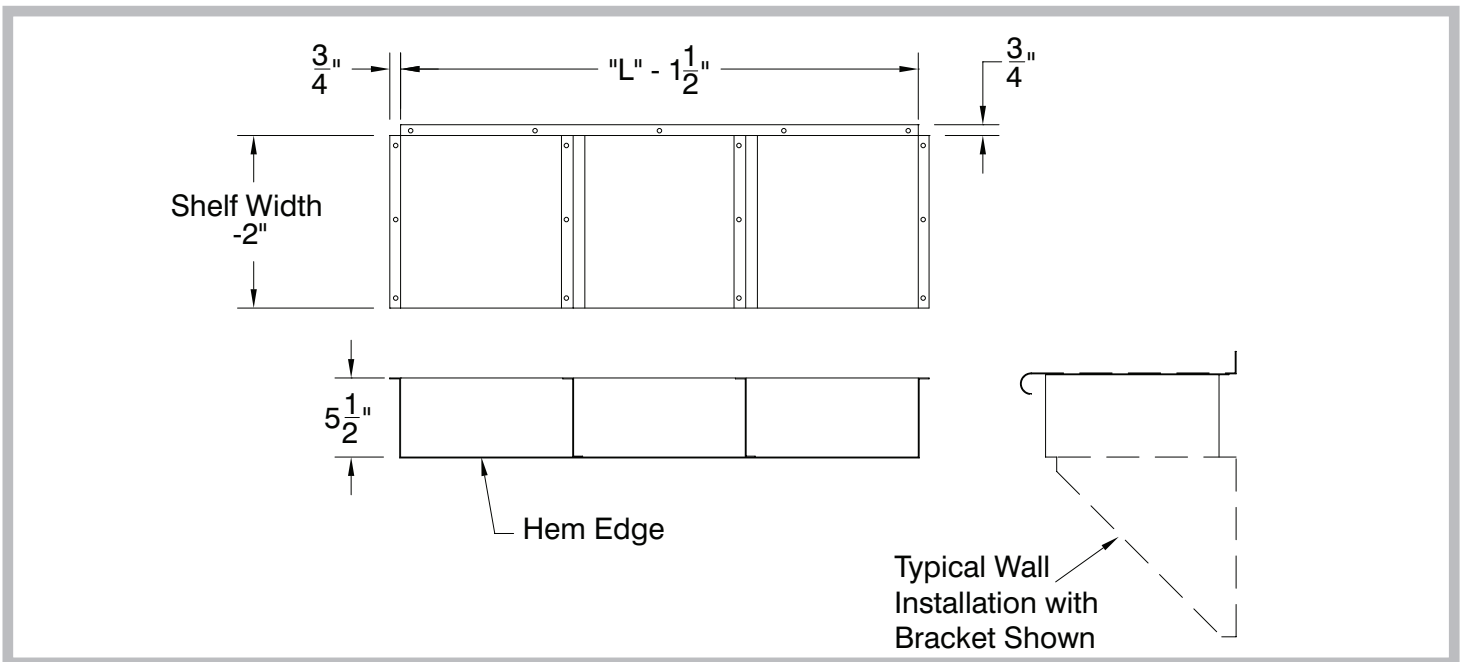

Customer Service Available To Assist You **1-800-645-3166** 8:30 am - 7:00 pm E.S.T.

For Orders & Customer Service:
 Email: customer@advancetabco.com or Fax: 631-242-6900

For Smart Fabrication™ Quotes:
 Email: smartfab@advancetabco.com or Fax: 631-586-2933