

MODEL: **IMD-ERV15SD / IMD-ERV25SD**
IMD-ERV35SD

BOTTLES COOLER: BLACK FINISH SOLID DOOR



General Strengths

- ✓ **Sanitation.** The interior cabinet is built with rounded corners (extensive radius for easy cleaning). Quick ability to take off shelves and slides for interior cleaning. Each cabinet has a drain at the bottom of the unit. When cleaning the unit make sure the drain hose is routed to a floor drain.
- ✓ **Doors.** Self-closing door system with permanent pressure. Stay open feature included when door remains open after 95 degrees. All doors include triple chamber door gaskets, easy to remove and snap in.
- ✓ **Control systems.** Higher precision in managing temperature settings. Greater ability for the adjustment of temperatures ranges as per the end user's requirement.
- ✓ **100% Tested.** All condenser units are tested 100%, in helium chambers for refrigerant leak detections.
- ✓ **Certified.** Audited and Certified by **INTERTEK** for compliance with UL 471 and NSF 7. EQA audited and certified by internationally recognized firm. ISO 9001:2015 (Quality); ISO 14001:2015 (Environmental); ISO 45001:2018 (Prevention and Worker Safety)
- ✓ **Lighting.** LED lighting in cabinet sides reduces the energy consumption by 80% and 90% compared to a traditional bulb. Provides a much better light quality.



**MODEL: IMD-ERV15SD / IMD-ERV25SD
 IMD-ERV35SD**

BOTTLES COOLER: BLACK FINISH SOLID DOOR

STANDARD FEATURES

➤ **Exterior**

- AISI 430 Stainless Steel.
- Completely injected compact structure.
- Door lock.
- Leveling feet.

➤ **Interior**

- Interior grey plastic-coated steel.

➤ **Doors**

- Triple chamber snap in door seals for easy removal.
- Black plastic handle included on the door.

➤ **Insulation**

- Polyurethane with high density 40kg/m³, CFSs free, zero ODP and low GWP.

➤ **Shelving**

- IMD-ERV15SD - (2) interior shelves.
- IMD-ERV25SD - (4) interior shelves.
- IMD-ERV35SD - (6) interior shelves.
- Guides and shelves easy to take off for cleaning.

➤ **Refrigeration**

- Temperature and defrost regulated by a digital controller.
- Forced air condensation system.
- Evaporative pan.
- Evaporator coil coated with anti-corrosion material.
- Refrigeration capacity:

IMD-ERV15SD - 1235 Btu/h (14°F) / 362W (-10°C).

IMD-ERV25SD - 1235 Btu/h (14°F) / 362W (-10°C).

IMD-ERV35SD - 1467 Btu/h (14°F) / 430W (-10°C).

OPTIONAL FEATURES

- ✓ Set of 2" Casters, front locking.
- ✓ Electrical connection is 220-230 V / 1ph / 50Hz (plug type varies).
- ✓ Electrical connection is 220-230 V / 1ph / 60Hz (plug type varies).

➤ **Electrical**

- Cord and NEMA 5-15P plug.
- Electrical connection is 115 V / 1ph / 60 Hz.



MODELS	Dimensions (inches) (mm)			Doors	Shelves	Ref.	Ref. Weight (Lbs.) (gr.)	Temperature Range (°F) (°C)	Cond. Unit	Capacity (Cu.Ft.) (L)	Case Amps 115V	Crated weight (Lbs.) (Kg.)
	W	D	H									
IMD-ERV15SD	23-3/4 (600)	20-1/8 (510)	35-3/4 (907)	1	2	R134a	0,42 (190)	39 °F/54 °F (+4°C/+12°C)	1/3	5 (140)	3,19	160 73
IMD-ERV25SD	35-1/2 (900)	20-1/8 (510)	35-3/4 (907)	2	4	R134a	0,68 (310)	39 °F/54 °F (+4°C/+12°C)	1/3	8 (220)	3,55	187 85
IMD-ERV35SD	53-1/4 (1350)	20-1/8 (510)	35-3/4 (907)	3	6	R134a	0,55 (250)	39 °F/54 °F (+4°C/+12°C)	1/4	11,6 (330)	4,59	213 97

**MODEL: IMD-ERV15SD / IMD-ERV25SD
 IMD-ERV35SD**

BOTTLES COOLER: BLACK FINISH SOLID DOOR

ELEVATION RIGHT VIEW PLANT VIEW

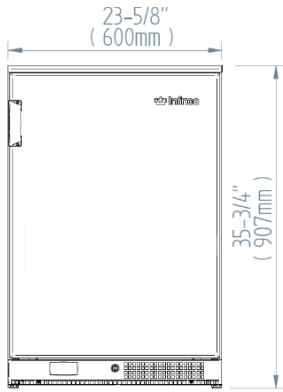

IMD-ERV15SD

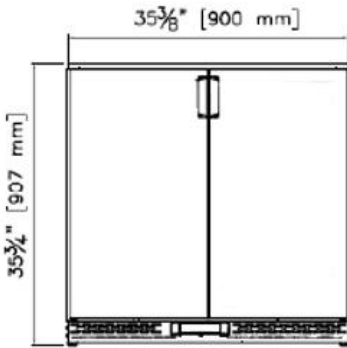
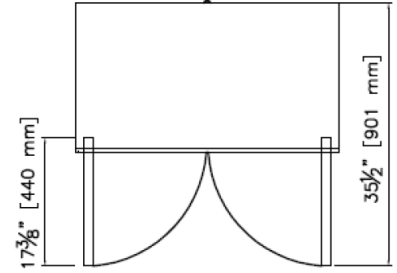
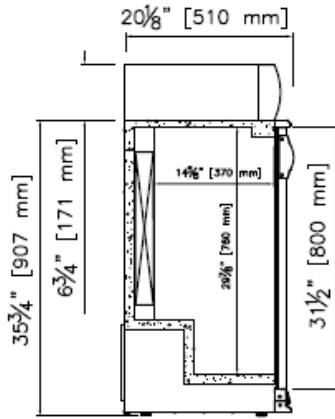

IMD-ERV25SD

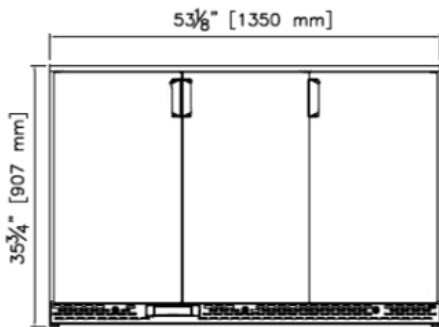
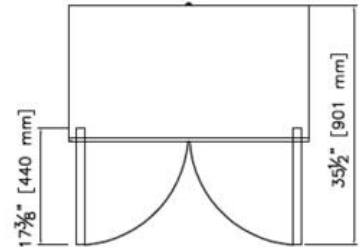
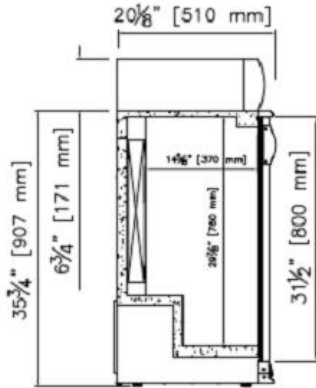

IMD-ERV35SD

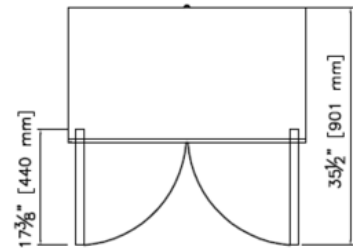
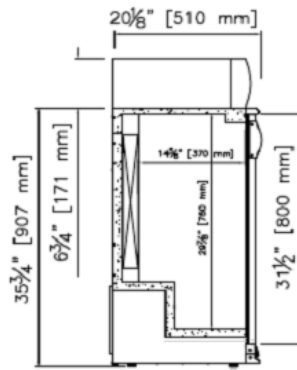

Revisión:02 Date: 03/10/2023 IMD-ERV15_25_35_SD

ETL LISTED TO UL471 STANDARD AND SANITATION CLASSIFIED TO NSF7 – WE RESERVE THE RIGHT TO CHANGE SPECIFICATIONS WITHOUT PRIOR NOTICE