

Refrigerated Pizza Prep Table with Condiment Rail

- Prep, store, and assemble pizzas with a refrigerated prep-table with granite top and glass-top condiment rail
- Improve kitchen flow and maintain organization
- Have toppings cool, visible, and within reach – streamlining service
- Casters (2 locking) included for easy mobility



UCPP566-SS61A



UCPP588-SS61A

Model	Description	Voltage/Hz/Phase/Amps	Shipping Weight
UCPP566-SS61A	65" 2 Door Refrigerated Pizza Prep Table + Condiment Rail	115v / 60hz / 1 / 6.5	772 lb
UCPP588-SS61A	88" 3 Door Refrigerated Pizza Prep Table + Condiment Rail	115v / 60hz / 1 / 6.5	992 lb

Specifications	
UCPP566-SS61A dimensions: 63 15/16" H x 65 1/8" W x 31 1/8" D	UCPP588-SS61A dimensions: 63 15/16" H x 88 11/32" W x 31 1/8" D
UCPP566-SS61A volume: 14 cu ft	UCPP588-SS61A volume: 21.89 cu ft
UCPP566-SS61A includes 4 epoxy coated wire shelves	UCPP588-SS61A includes 6 epoxy coated wire shelves
AISI 304 stainless steel interior and exterior with granite worktop and refrigerated condiment rail, ETL sanitation certified	
Autodefrost	
CFC-free high-density polyurethane insulated cabinet	
Electronic digital temperature control with alarms	
Environmentally friendly R449a/R134a (top) refrigerant: UCPP566-SS61A: 10.6 oz (0.280 kg) / 7.0 oz (0.200 kg) UCPP588-SS61A: 17.5 oz (0.500 kg) / 8.8 oz (0.250 kg)	
Factory pre-wired for dedicated outlet, 11 ft cord and plug included NEMA 5-15P	
Granite and glass-top assembly required	
High efficiency compressor, side mount	
High efficiency evaporator coil & condenser	
Interior rounded corners for easy cleaning	
NSF/ANSI Standard 7 compliant	
Pans not included	
Self-lubricating, sealed cast iron evaporator fan motor with high volume airflow design	
Temperature range: 28°F to 46°F	

Accessories	Description	Shipping Weight
ULA4082514	(1) Stainless steel shelf guide for prep tables, 24"	.88 lb
ULAQ32-4666-ETL	(1) Epoxy coated wire shelf, 17 7/8" x 25 7/8" for prep tables	2.2 lb



Product Specifications • Refrigerated Pizza Prep Table

Front (2 Door with Condiment Rail)

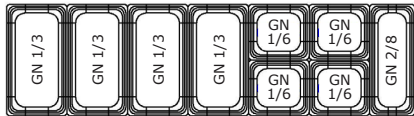
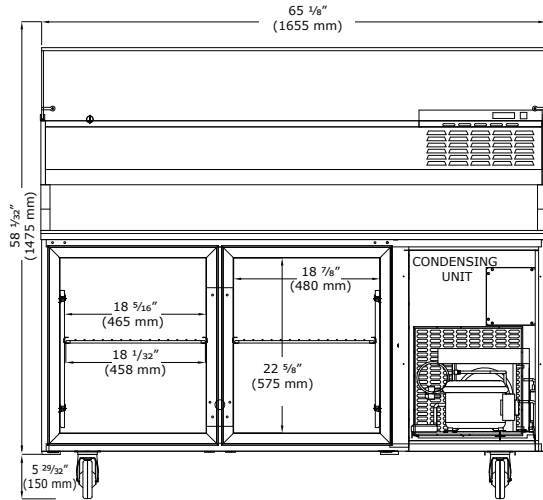

UCPP566-SS61A condiment rail (for reference only - pans not included)

Side

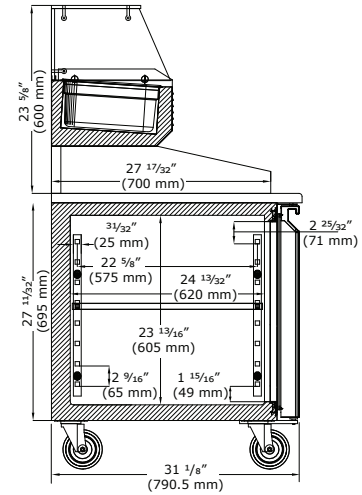

Front (3 Door with Condiment Rail)

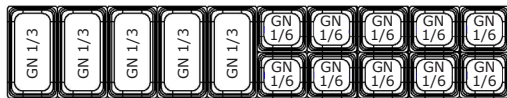
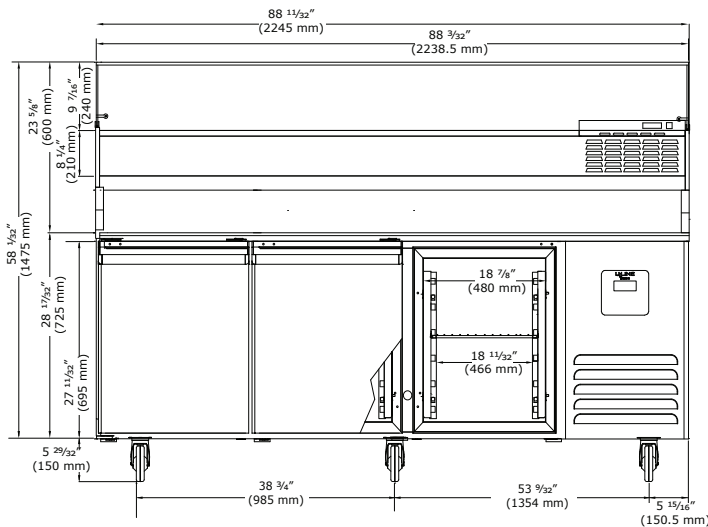

UCPP588-SS61A condiment rail (for reference only - pans not included)

Top

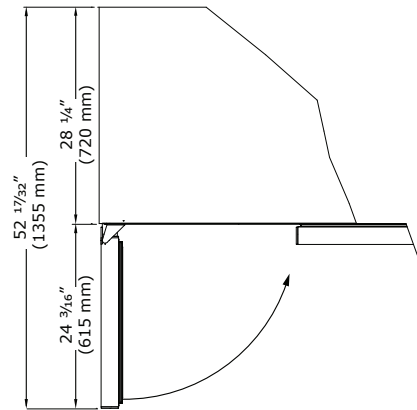

Commercial Warranty

3 Year (parts & labor) / 5 year sealed system (parts)
See complete warranty for details

