

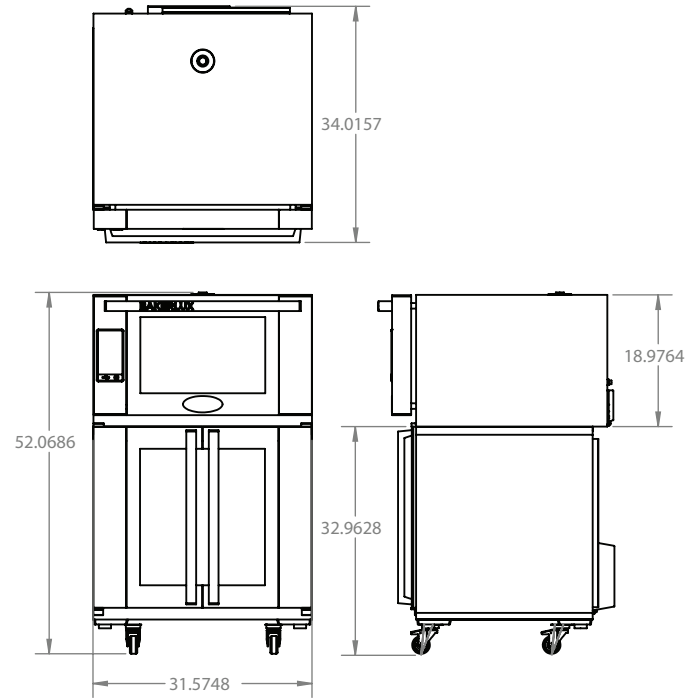

# Bakerlux Proofer Station

## Full-Size

### Model: BLS-4FSLD-PRF

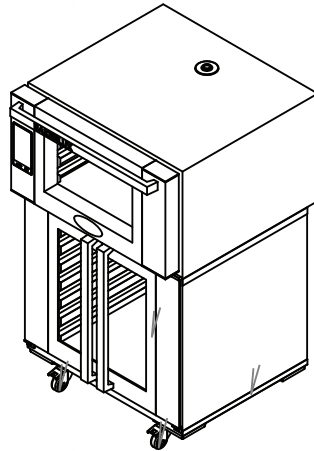

#### Oven Features and info

- \* Shelves included (4)
- \* 3 baking steps
- \* Includes electro valve for direct plumbed water connection
- \* Up to 99 programs, including 12 "Quick Access" programs
- \* Handles standard half size or full size sheet pans (not included)
- \* 3 fan speeds
- \* Light flashes and unit beeps at end of cooking cycle

#### Proofer Features and Info

- \* Handles 8 sheet pans (not included)
- \* Temperatures to 122°F
- \* Adjustable legs or optional casters
- \* Freight class 200 (NOTE: These models must ship by truck, not UPS)
- \* Oven & proofer are both controlled by the control panel on the oven
- \* Proofers are NOT designed for stand-alone use
- \* Proofers require water hookup
- \* Casters are included

Our proofers are made to Cadco Ltd. specifications by UNOX S.p.A., Italy  
NSF, MET to UL & CSA Standards

#### Incoming Water:

The bottom of the appliance contains 6.ft 7 in of pipe with a tee for connecting to the water supply (including mechanical filter and fitting (3/4") with non-return valve). A shut-off valve should be positioned between the water mains and the appliance.

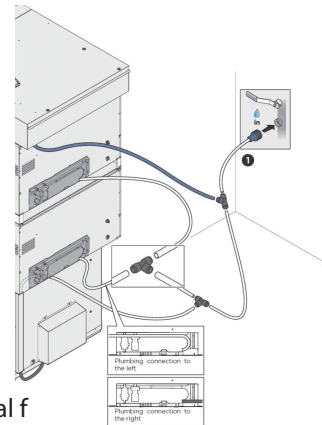

#### Bakerlux Proofer Station Includes:

| Model        | Color     | Volts   | Watts | Amps | Unit Dimensions            |
|--------------|-----------|---------|-------|------|----------------------------|
| XAFT-04FS-LD | Stainless | 208-240 | 7600  | 32   | w:31.5", h:19.62", d:35.5" |
| XAKPT-08FS-C | Stainless | 208/240 | 1300  | 5.5  | w: 32", h:36", d:32"       |

**Shipping Unit Dimensions**  
1 SKID CLASS 200  
325 POUNDS -1 OVEN, 1 PROOFER

#### LED digital programmable controls:

- 3 BAKING STEPS
- 0 - inf. TIMER
- 120° - 500° F TEMPERATURE
- 0-20-40-60-80-100% HUMIDITY
- 2 FAN SPEEDS
- PROOFER CONTROL
- 99 PROGRAMS  
12 QUICK ACCESS

### 3 YEAR WARRANTY



www.cadco-ltd.com



860.738.2500



info@cadco-ltd.com