

HIGH EFFICIENCY FRYER

GAS TYPE: NATURAL LP



AF-50HE

STANDARD FEATURES

- Energy efficient burner/baffle system – increases cooking production while lowering the flue temperature
- All stainless steel front and sides
- Heavy gauge stainless steel tank
- Energy efficient burner rated at 75,000 BTU/hr. Millivolt control system with 100% safety shut off
- Thermostatic control with 200°F to 400°F range
- 1-1/4" full port drain valve
- 4" legs or optional casters
- Two year limited warranty, parts, and labor (Five year tank warranty)

OPEN BURNERS

- Stainless steel tank cover
- Four casters front two with locking brakes
- Matching "Dump Station"
- Stainless steel Splash Guard
- Joiner Strip: Connects two fryers and prevents oil from getting in between the fryers or drain station



Model Shown AF-50HE

Shown with optional casters

DESCRIPTION

American Range, ENERGY STAR® Fryer 50 pound fryer, model AF-50HE. Energy efficient burner baffle systems increase production, and lowers flue temperature. All stainless steel front and sides, with heavy gauge stainless steel tank and burner rated at 80,000 BTU/hr. Standard millivolt control system with 100% safety shut off and Thermostatic control with a temperature range of 200°F to 400°F. 1-1/4" full port drain valve for easy cleaning. Two year limited warranty, parts, and labor. Five year tank warranty.



HIGH EFFICIENCY FRYER

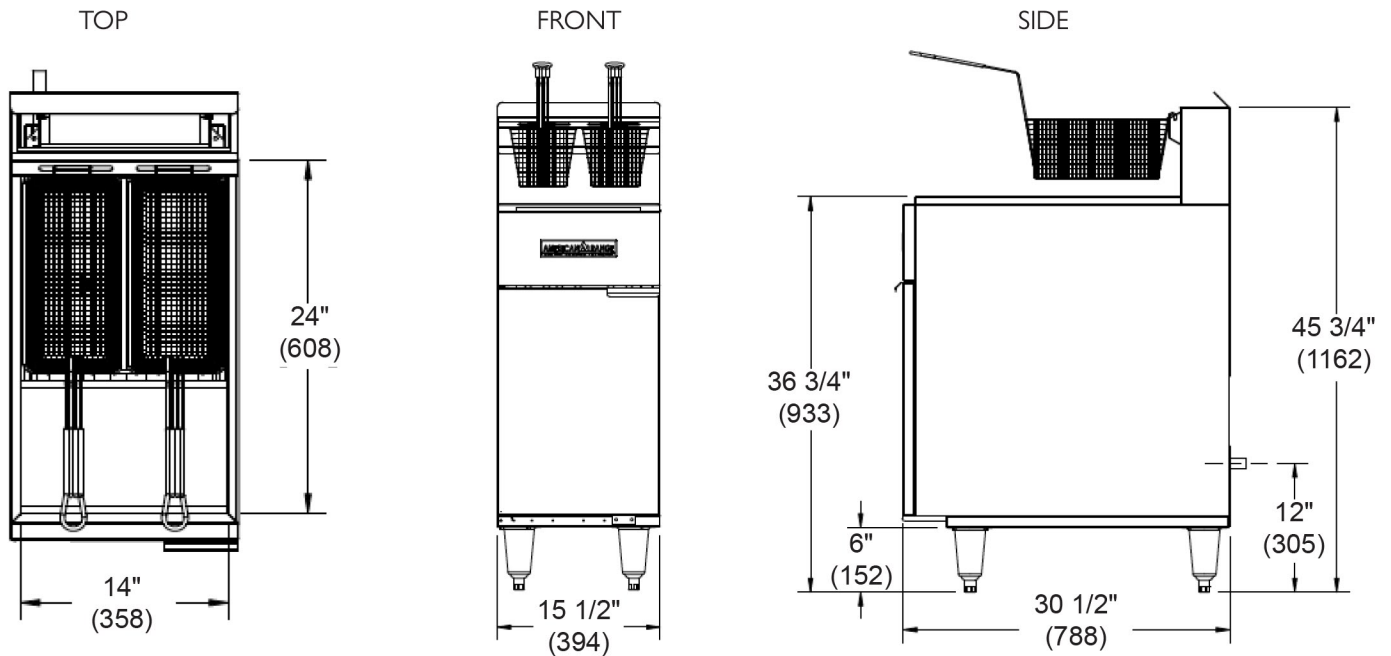

Shipping Weight*

MODEL	WIDTH (MM)	DEPTH (MM)	HEIGHT (MM)	BURNERS	COOKING AREA	BTU/hr.	(kW)	LBS	(KG)
AF-50HE	15 1/2" (394 mm)	30-1/2" (788 mm)	45-3/4" (1162 mm)	1	(1) 14" x 14" (356 mm x 356 mm)	75,000	(22)	150	(68)

- (A99415) Stainless steel tank cover
- (A99251 left) Stainless steel Splash Guard
- (A99252 right) Stainless steel Splash Guard
- (A99412) Joiner Strip: Connects two fryers and prevents oil from getting in between the fryers or drain station

Specify type of gas and altitude if over 2000 feet.

NATURAL GAS	MANIFOLD PRESSURE		MANIFOLD SIZE
	PROPANE GAS		
5.0" W.C.	10.0" W.C.	3/4" (19MM)	

*Shipping weight includes packaging and is approximate.

American Range is a quality manufacturer of commercial cooking equipment. Due to continuing product improvements, these specifications are subject to change without prior notice.

COMBUSTIBLE WALL CLEARANCES:

For use only on non-combustible floors. Legs or casters are required, or 2" (51) overhang is required when curb mounted. Clearance from non-combustible walls is 0". When unit is placed next to combustible walls, clearances must exceed 12" (305) from sides, and 4" (102) from rear.

Commercial cooking equipment requires an adequate ventilation system. For additional information, refer to the National Fire Protection Association's standard.

NFPA96 "Vapor Removal from Cooking Equipment." (NOTE: For North America only)

DESIGNED & BUILT IN USA
PROFESSIONAL COOKING EQUIPMENT

A70612 Rev B 03182025



AMERICAN RANGE
A **HATCO** COMPANY

13592 Desmond St Pacoima CA 91331
T. 818.897.0808 Toll Free: 888.753.9898
www.AmericanRange.com