



BEVERAGE-AIR

Project: _____	AIA#
Item: _____	
Location: _____	SIS#
Approved: _____	

WTCTCS72HC CROSS TEMP CHEF BASE

CROSS TEMP CHEF BASE

WTCTCS72HC Four Drawer Cross Temp Chef Base
Hydrocarbon Series

MODEL:
WTCTCS72HC



7 Year Parts/Labor Warranty
7 Year Compressor Warranty

CABINET CONSTRUCTION

- Stainless steel front, sides, drawers and grille (galvanized back & bottom)
- Interior liner is made of corrosion resistant aluminum
- Top has full marine edge to prevent spills from dripping over sides
- Full electronic control, configurable to all menu initiatives, temperature range of -15 to 40°F
- Top weight capacity 1500 lbs
- Easily converts from refrigerator to freezer
- One-piece, snap-in magnetic drawer gasket
- 12-Gauge stainless steel drawer slides with Delrin® rollers rated at 275 lbs
- Lifetime warranty on all drawers and slides
- Heavy duty, fire-proof, insulated 16 gauge top
- No heat shield required (must adhere to proper clearance per owners manual)
- Accommodates 6" deep full size food service pans (not included)
- Self-closing drawer feature
- Compressor available on left or right, specify at time of unit order
- 3" Casters, 2 with brakes standard

OPTIONS & ACCESSORIES

- Stainless steel back
- Stainless steel interior
- Additional pan supports
- 6" Adjustable legs, 6" seismic legs
- 6" Casters
- Gasket guards
- Flat top overhang
(up to 6" overhang on each side)
- Remote option*
(refrigerant must be specified at time of order, see note on back on page)

REFRIGERATION SYSTEM

- Uses environmentally friendly, energy efficient R290 refrigerant, and meets all regulatory requirements for CARB, SNAP, DOE & more
- Adaptive defrost
- Non-electric defrost with hot gas condensate evaporation



Please verify qualifying units by visiting:
www.energystar.gov/cfs

3779 Champion Blvd., Winston-Salem, NC 27105
1-888-845-9800 Fax: 1-336-245-6453
Beverage-Air.com Sales@bevair.com



BEVERAGE-AIR

MODEL	WTCTCS72HC
EXTERNAL DIMENSIONAL DATA	
Width Overall (in)	72"
Depth Overall (with handle & bumper) (in)	34 ³ / ₄ "
Height Overall (with casters) (in)	24 ³ / ₈ "
No. of Drawers / Pans	4 / 8 Full size
Depth with Drawers Extended (in)	57 ³ / ₄ "
Drawer Openings (in)	(4) 27 ³ / ₈ " x 6 ¹ / ₂ "
INTERNAL DIMENSIONAL DATA	
NET Capacity (cubic ft.)	12.30
Internal Width Overall (in)	58"
Internal Depth Overall (in)	22 ³ / ₈ "
Internal Height Overall (in)	16 ³ / ₈ "
ELECTRICAL DATA	
Full Load Amperes	8.7
Voltage	115/60/1
Nema Plug (8' cord)	5-15P
REFRIGERATION DATA	
Horsepower	4/5
Capacity (BTU/Hr)	1970 - 4950
Heat Rejection (BTU/Hr)	2955 - 7425
Charge (lbs/grams/ounces)	0.331 / 150 / 5.29
WEIGHT DATA	
Gross Weight - Crated	575 lbs
Height - Crated	27"
Width - Crated	78"
Depth - Crated	38"

*NOTE: Remote units are field wired and come with 6" legs. Refrigerant must be specified at time of order.

We reserve the right to change specifications and product design without notice. Such revisions do not entitle the buyer to corresponding changes, improvements, additions or replacements for previously purchased equipment. Dimensional tolerances +/- 1/4". Metric dimensions (MM).

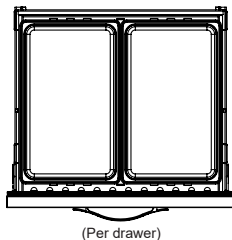

ELECTRICAL CONNECTION



115/60/1
NEMA 5-15P

Unit pre-wired at factory and include 8' long cord and plug set.

* NOTE: Units that utilize variable speed compressor technology can experience nuisance tripping on Class A GFCI outlets which have a trip limit of 4 to 6 mA. To avoid this issue in a location that requires GFCI circuit protection, Beverage-Air recommends using either an Eaton, SGF20, or HUBBELL Model Number GFRST83W 20A Heavy Duty Hospital Grade Self-Test GFCI Receptacle.

Cross Temp Chef Base Model: WTCTCS72HC

Model Views

Required Clearance: Bottom 3 ¹/₄" & Rear 1"

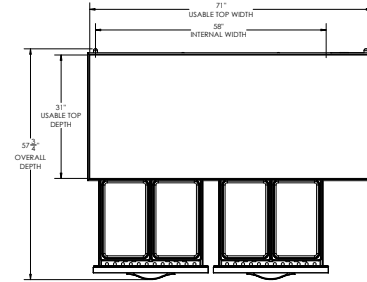

PLAN VIEW

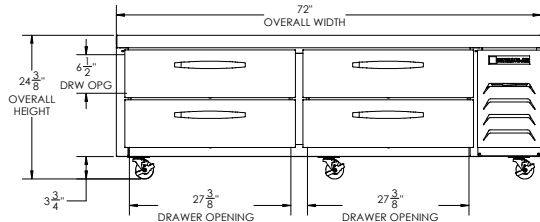

ELEVATION VIEW

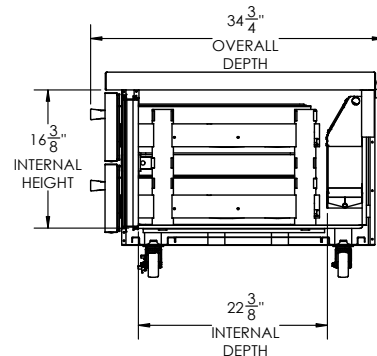

SIDE VIEW

