

KoldCube³ HYBRID INSULATED INDOOR/OUTDOOR COLD CABINET MODEL KC-UA-11

FEATURES AND BENEFITS:

- The industry's first mobile insulated refrigerated unit allowing you to transport and hold cold food safely indoors or out with or without a cord!
- Allows you the flexibility to use indoors with standard 120 Volt electric, then unplug and use outdoor cooling system, or connect to 12VDC system.
- No need for a generator with new cutting edge battery and solar power - hold up to 3-6 hours outdoors without a cord!
- Fully insulated 3/4 size holding cabinet keeps foods at proper cold holding temperatures.
- Eleven sets of locking transport angles accommodate a large variety of pan sizes on adjustable 1-1/2" centers. Provides capacity up to (22) 12 x 20 steam table pans.
- Heavy duty 8" all-terrain swivel casters, front two with brakes. Rear casters are fixed to provide mobility when fully loaded, and stability during transport even in tough outdoor conditions.
- Smooth interior coved corners prevent food particle/grease buildup.
- Constructed with sun reflective coating to shield the unit from sun rays, customize the unit by adding your own logo with a vinyl door graphic or door magnet!
- Complete your "Off The Grid" food holding and transport needs with the KoldCube³ and HotCube³ companion heavy duty all terrain cabinets.
- For model with high capacity battery (6-8 hours of hold time rather than standard 3-6 hours), use model number KC-UA-11H.



KC-UA-11

ACCESSORIES and OPTIONS (Available at extra cost):

- Solar Panel
- High Capacity Battery (6-8 Hours Hold Time)
- Bluetooth Battery Monitor Adapter Kit
- Customized Vinyl Graphic/Door Magnet
- Extra Heavy Duty Transport Angles
- 6" Hi-Modulus Casters

See page K-5 for accessory details.

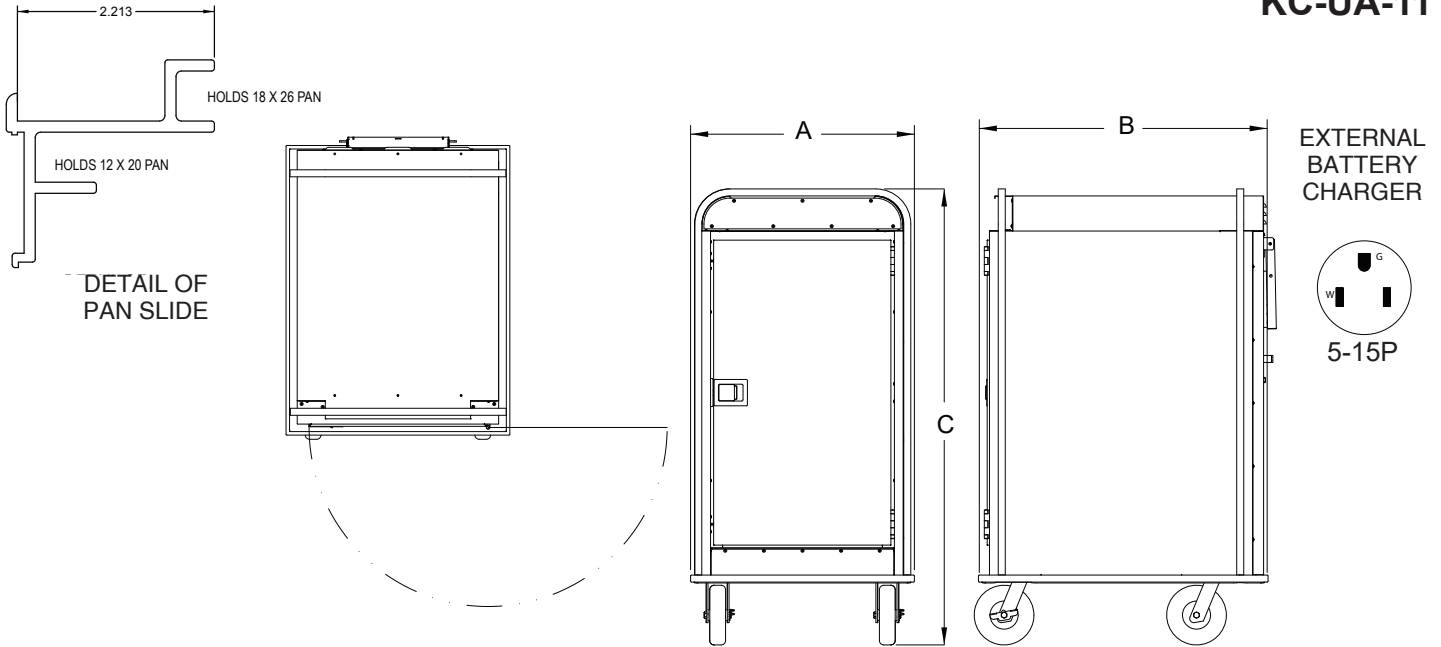

CRES COR MODEL NO.	PAN			DIM "A"	DIM "B"	DIM "C"	INSIDE DIMENSIONS				WEIGHT ACT.
	CAP/ANGLES	SIZE		WIDTH	DEPTH	HEIGHT	WIDTH	DEPTH	HEIGHT		
KC-UA-11	11 SETS	SEE NOTE BELOW	IN	31-7/8	41	66	23-3/4	27-1/4	42	LBS	468
			MM	810	1041	1676	603	692	1070	KG	212

NOTE: Pan sizes 18" x 26" (460 x 660) Bun Pans, 12" x 20" (305 x 510) Steam Table Pans.

CABINET:

- Inner body: 22 ga. stainless steel.
- Outer body: .063 aluminum, powder coated white aluminum.
- Reinforcement: Internal framework of 20 ga. stainless steel.
- Insulation: Foam in place in back, top, bottom and door. Foam and fiberglass on sides.
- Push/pull handles (2) powder coated blue.
- Interior coved corners.

BASE:

- One piece construction, .060 stainless steel.
- Casters: 8" dia., (2) swivel (2) fixed, all-terrain, load cap. 310 lbs. each. Front wheels equipped with brakes.

DOOR:

- Formed 22 ga. stainless steel.
- Latches: Polished stainless steel, slam type; mounted inboard.
- Gasket: Magnetic type.

TRANSPORT PAN SLIDES:

- Extruded aluminum; mounted on locking lift-off posts.
- Spaced on 3" centers; adjustable on 1-1/2" centers.

ELECTRICAL COMPONENTS:

- 12V DC Electrical System.
- Switch: On/Off.
- Battery indicator.
- External Battery Charger.
- Thermostat: 38°F fixed. (3° C)
- Digital thermometer.

POWER REQUIREMENTS:

- 120 Volts, 60 Hz., single phase, 3 Amps., 15 Amp. service.
- Battery system 12 Volt rechargeable.

SHORT FORM SPECIFICATIONS

Cres Cor Insulated KoldCube³ Cabinet Model KC-UA-11 outer of .063 aluminum, stainless steel internal frame. (11) sets of locking transport angles for multiple pan sizes, adjustable spacing every 1-1/2". Inner body stainless steel. Foam insulation in sides; doors, back, top, and sidewalls. Interior coved corners. One piece base, stainless steel. 8" all-terrain wheels, front swivel with brake, rear wheels are fixed. Load capacity 310 lbs. each. 2 year parts warranty. 2-Year Parts / 1-Year Labor warranty. Provide the following accessories: _____.



Scan QR code to view Spec Sheet, Operating Manual, Wiring Diagram or to call Customer Service.

If you need a QR reader visit your App Store on your Smartphone or Tablet.



5925 Heisley Road • Mentor, OH 44060-1833
Phone: 877/CRESCOR • Fax: 440/350-7267
www.crescor.com

© Crescent Metal Products, Inc. 2019 All rights reserved.

In line with its policy to continually improve its products, CRES COR reserves the right to change materials and specifications without notice.

Made in America Since 1936