

Portable Landing Table

Model LT



With the versatile **Giles Portable Landing Table**, you have all the extra room you need!

The **Giles LT** is a versatile worktable-cart combination that easily provides extra workspace for the kitchen. The Holding Pan has an opened front, allowing easy loading and unloading, and accommodates a 18" x 26" sheet pan. For added convenience, the new **LT** also comes standard with a removable center shelf.

Optional side racks are also available for the **Giles Landing Table**. These act as storage racks and help keep supplies and pans within arm's reach. Durable locking casters, allow for ease in mobility and when locked make the **LT** a safe, stationary, kitchen work station.

The easy lift-off optional storage racks and completely stainless steel construction make clean-up easy.

Design Features



Removable Racks
 Optional side racks are also available, adding extra storage space and making the **LT** a must for any foodservice operation.

Counter Top
 A convenient Counter-Top version of the **Giles landing Table (Model LT-C)** is available and comes with a removable sheet pan and glazing rack.



Listings



Giles Foodservice Equipment

An ISO 9001 Registered Company

2750 Gunter Park Drive West • Montgomery, AL 36109 USA

Phone 334.272.1457 • Fax 334.239.4117 • Phone Toll Free: 800.554.4537

Web Site: www.gfse.com • Email: services@gfse.com

Portable Landing Table

Model LT

Item No.: _____
 Quantity: _____
 Project Name: _____
 SIS#: _____
 AIA/CSI#: _____

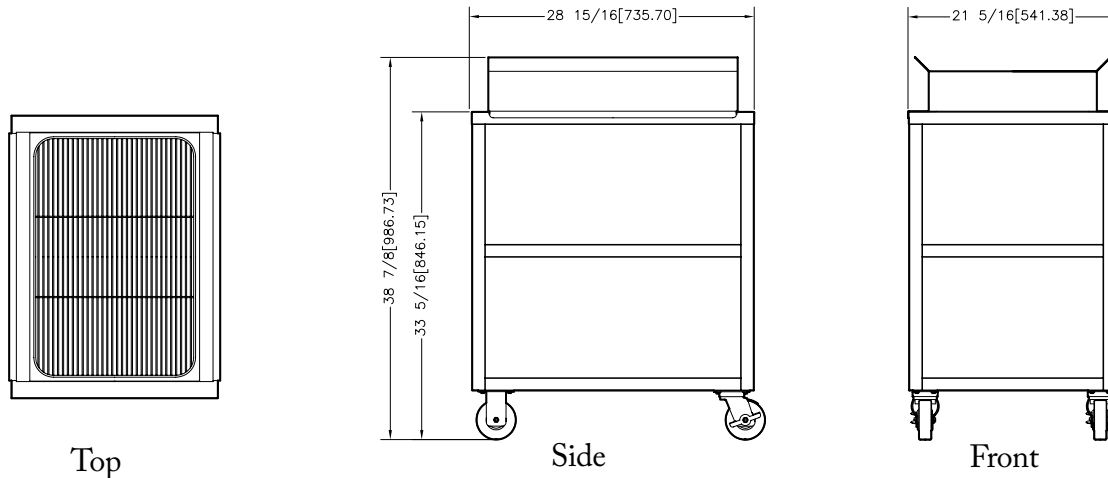

Inches [millimeters]

Specifications

We reserve the right to change specifications and product design without notice. Such revisions do not entitle the buyer to corresponding changes, improvements additions or replacements for previously purchased equipment.

Construction:

Cabinet and Shelves: 18Ga Stainless Steel

Dimensions:

Width: 23-3/16" [590 mm]

Depth: 26-5/16" [669 mm]

Height: 36-3/8" [924 mm]

Glazing Screen:

16-1/5" Width X 24-1/2" Length

[419 mm X 622 mm]

Bisquit Pan:

18" Width X 26" Length

[457 mm X 660 mm]

Listings:

NSF

Product Designation:

LT

Shipping Specifications:

Crated Weight: 79 lbs [36 kg]

Crated Cube Size: 24" X 28" X 37" = 15 cu ft

[610 mm X 711 mm X 940 mm = .4 cu meters]

Accessories Included

Standard Unit is shipped with (1) Holding Pan, (1) Glazing Screen, (1) Full Size Sheet Pan

How To Specify

1. Models

Specify the part number from the following:

Qty	Model	Part Number
<input type="checkbox"/>	LT-3 (without side racks)	79592
<input type="checkbox"/>	LT-3 (with side racks)	79588
<input type="checkbox"/>	LT-3 Counter Top	79591
<input type="checkbox"/>	LT-3 (without pan)	79677

2. Accessories*

Specify the part number and quantity of the following accessory items needed:

Qty	Description	Part Number
<input type="checkbox"/>	Glazing Screen	77175
<input type="checkbox"/>	Full Size Sheet Pan	78602
<input type="checkbox"/>	Pan Racks	32329

*Additional charges

3. Shipping

Specify the shipping method

Giles Foodservice Equipment

2750 Gunter Park Drive West • Montgomery, AL 36109 USA

Phone 334.272.1457 • Fax 334.239.4117 • Phone Toll Free: 800.554.4537

Web Site: www.gfse.com • Email: services@gfse.com