

N900

Read each section of this manual before installing and operating

Leggere tutte le parti di questo manuale prima di installare o mettere in funzione l'apparecchiatura.

Lire toutes les parties de ce mode d'emploi avant d'installer ou mettre en fonction l'appareil.

Leer todas las partes de este manual antes de llevar a cabo la instalación o de poner en marcha el aparato.

- CUOCIPASTA
INSTALLAZIONE, USO E MANUTENZIONE
- PASTA COOKER
INSTALLATION, USE AND MAINTENANCE
- CUISEUR DE PÂTES
INSTALLATION, UTILISATION ET MAINTENANCE
- CUECEPASTAS
INSTALACIÓN, USO Y MANTENIMIENTO

Pag. 5

Page 15

Page 25

Pág. 35

WARNING: Improper installation, adjustment, alteration, service or maintenance can cause property damage, injury or death. Read the installation, operating and maintenance instructions thoroughly before installing or servicing this equipment

FOR YOUR SAFETY

Do not store or use gasoline or other flammable vapors or liquids in the vicinity of this or any other appliance.

AVVERTENZA: Installazione impropria, adattamenti, modifiche o manutenzione possono causare danni alla proprietà o morte. Leggere attentamente le istruzioni per l'installazione, il funzionamento e la manutenzione prima di installare questa apparecchiatura

PER LA VOSTRA SICUREZZA

Non immagazzinare o usare benzina o altri materiali infiammabili o liquidi nelle vicinanze di questa o qualsiasi altra apparecchiatura.

AVERTISSEMENT: L'installation, l'adaptation, la modification et l'entretien inadéquats peuvent causer des dommages aux structures ou aux personnes et la mort. Lire attentivement les instructions d'installation, de fonctionnement et d'entretien avant d'installer cet appareil

POUR VOTRE SECURITE

Il ne faut pas emmagasiner ou utiliser l'essence ou d'autres matériaux inflammables ou liquides à côté de cet appareil ou d'autres appareils.

ADVERTENCIA: Una instalación inadecuada, lo mismo que modificaciones y operaciones de mantenimiento incorrectas pueden causar daños a la estructura y a las personas y provocar la muerte. Antes de instalar el aparato leer con mucha atención las instrucciones de la instalación, del funcionamiento y del mantenimiento

PARA SALVAGUARDAR VUESTRA SEGURIDAD

No almacenar o utilizar gasolina u otros materiales inflamables o líquidos cerca de este u otros aparatos.



DOC. NO. 5978 17801
EDITION 1 2008 03

IA. SCHEMA DI INSTALLAZIONE - INSTALLATION DIAGRAM - SCHÉMA D'INSTALLATION - ESQUEMA DE INSTALACIÓN

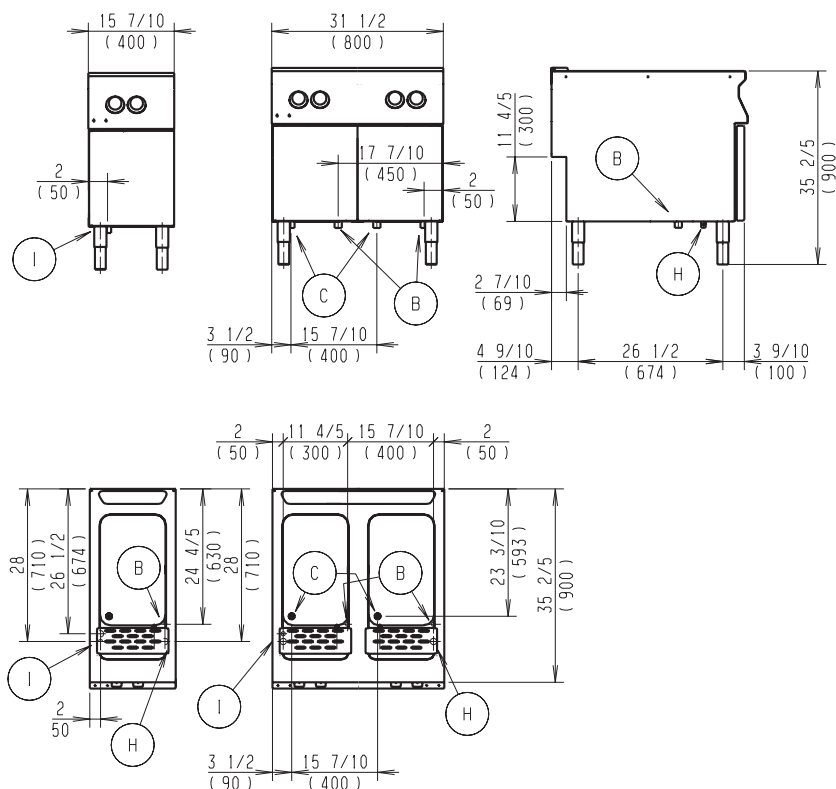

GB

- B** - Water connection inlet
- I** - Power supply cable inlet
- C** - Water drain connection
- H** - Gas connection inlet

• If the appliance is not installed under an extraction hood, the draught diverter may be requested to the manufacturer

FR

- B** - Entrée eau
- I** - Entrée câble électrique
- C** - Ecoulement eau
- H** - Entrée gaz

• Si l'appareil ne doit pas être installé sous une hotte d'aspiration il est nécessaire d'appliquer un dispositif anti-refouler, à demander au producteur.

IT

- B** - Attacco alimentazione acqua
- I** - Entrata cavo elettrico
- C** - Attacco scarico acqua vasca
- H** - Attacco gas

• Qualora l'apparecchiatura non dovesse essere installata sotto una cappa d'aspirazione si rende necessario il montaggio dell'interruttore di tiraggio, da richiedere al costruttore.

ES

- B** - Conexión de agua
- I** - Ingreso cable eléctrico
- C** - Conexión de descarga agua
- H** - Conexión de gas

• Cuando el aparato no sea instalado debajo de una campana extractora, el cortatiro puede ser requerido al fabricante.

Danger! Explosion hazard.

In the event a gas odor is detected, shut down equipment at the main shut-off valve. Immediately call the emergency phone number of your gas supplier.

Pericolo! pericolo di esplosione.

Nel caso in cui venga avvertito odore di gas spegnere l'apparecchiatura chiudendo la valvola principale a monte della stessa. immediatamente telefonare al numero d'emergenza del vostro fornitore di gas.

Danger! Danger d'explosion.

Si l'on sent l'odeur de gaz, arrêter l'appareil en fermant la soupape principale en amont. Téléphoner immédiatement au numéro d'urgence de votre fournisseur de gaz.

Peligro! peligro de explosión.

En el caso que se sienta olor de gas, apagar inmediatamente el aparato cerrando la válvula principal colocada aguas arriba de la misma. Llamar inmediatamente el número de teléfono de emergencia de la compañía erogadora del gas.

1. UNIONE APPARECCHIATURE - COMBINING APPLIANCES - UNION D'APPAREILS - UNIÓN DE VARIOS EQUIPOS

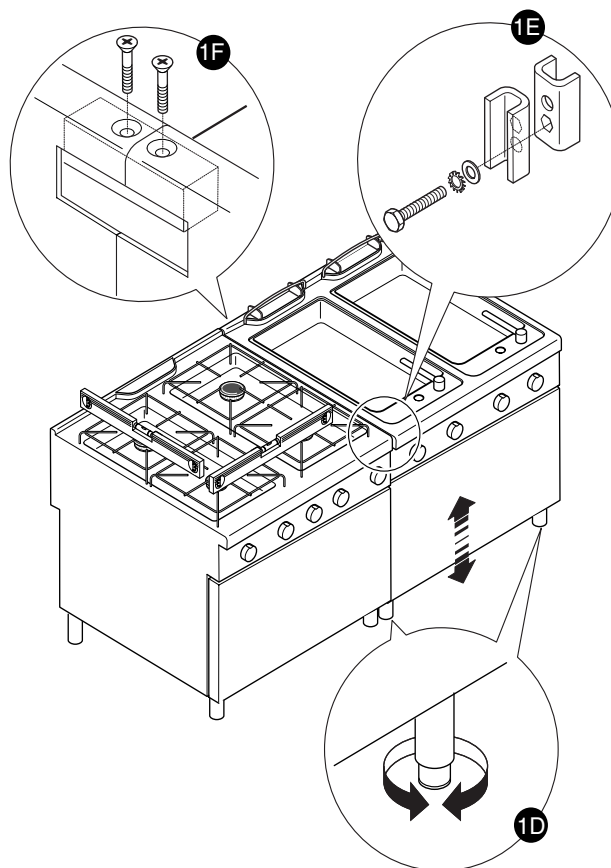
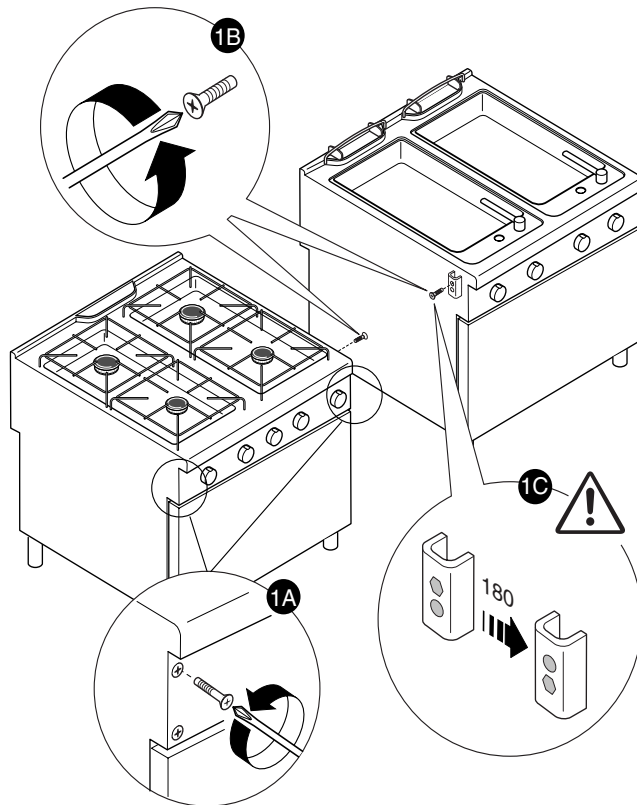

2. PROSPETTO VALVOLE/RUBINETTI GAS - FIGURE GAS VALVE/TAPS - TABLEAU DES SOUPAPES/ROBINETS DE GAZ - FIGURA VÁLVULAS/LLAVES DE GAS

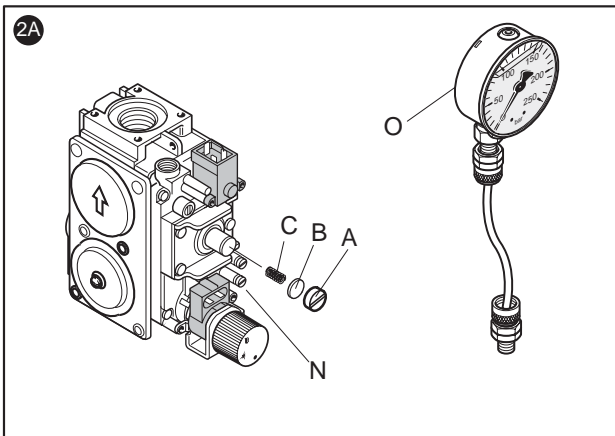

3. PROSPETTO BRUCIATORI/PILOTI GAS - FIGURE GAS BURNERS/PILOTS - TABLEAU DES BRÛLEURS/VEILLEUSES GAZ - FIGURA QUEMADORES/PILOTOS GAS

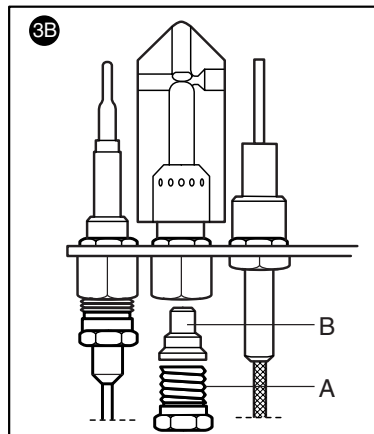
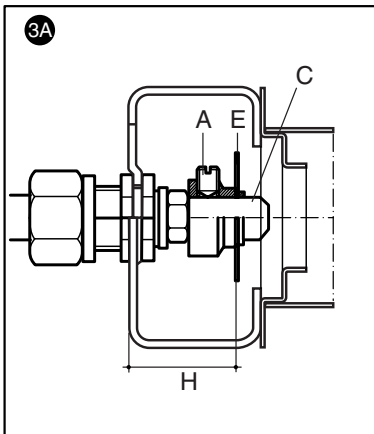

4. PROSPETTO COLLEGAMENTI ELETTRICI - ELECTRICAL CONNECTIONS - TABLEAU DES BRANCHEMENTS ÉLECTRIQUES - VISTA DE LAS CONEXIONES ELÉCTRICAS

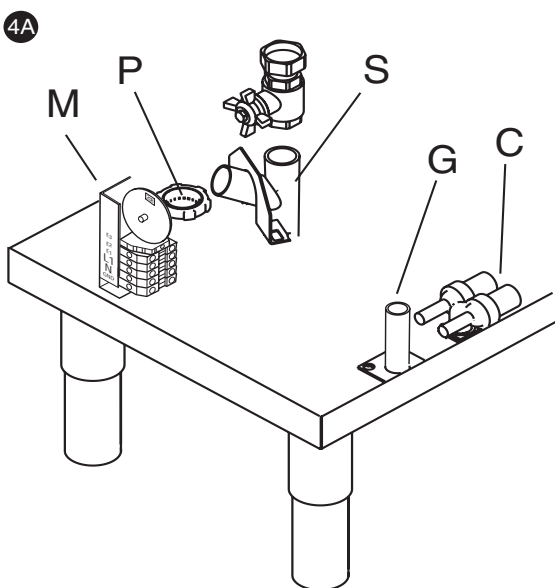

Summary

II. GENERAL INFORMATION	18
1. INSTRUCTIONS	18
2. THE ENVIRONMENT	18
2.1. Packing	18
2.2. Use	18
2.3. Cleaning	18
2.4. Disposal	18
2.5. Radio interference	18
III. INSTALLATION	19
1. GUIDELINES	19
2. UNPACKING	19
3. POSITIONING	19
3.1. General Information	19
3.2. Securing to the floor	19
3.3. Combining appliances	19
3.4. Assembly and joining of counter top appliances on base, oven, bridge and cantilever frame	19
3.5. Sealing gaps between appliances	19
4. FUME EXHAUST	19
4.1. Warning	19
4.2. Ventilation	20
5. CONNECTIONS	19
5.1. Gas appliances	20
5.1.1. Before connection	20
5.1.2. Connection	20
5.1.3. Supply pressure check	20
5.1.4. Gas pressure regulator	21
5.1.5. Supply pressure adjustment	21
5.1.6. Primary air control	21
5.1.7. Conversion to another type of gas	21
5.1.7.1 Replacing main burner nozzle (fig. 3A)	21
5.1.7.2 Replacing pilot burner nozzle	21
5.1.7.3 Valve gas conversion kit use	22
5.2. Electric appliances	22
5.2.1. Electrical connection (fig 4A)	22
5.2.2. Circuit breaker	22
5.3. Equipotential node and earth connection	22
5.4. Connection to the mains for models with Voltage change	22
6. WATER SUPPLY CONNECTION	22
7. DRAIN	22
8. BEFORE COMPLETING THE INSTALLATION OPERATIONS	22
IV USER INSTRUCTIONS	23
1. PASTA COOKER USE	23
1.1. Water filling	23
1.2. Gas models	23
1.3. Electric models	23
1.4. Cooking (valid for gas and electric models)	24
1.5. Water discharge	24
1.6. Models with instantaneous heater	24
1.7. Model with cooking timer acoustic signal	24
V. CLEANING	25
1. EXTERNAL PARTS	25
2. OTHER SURFACES	25
3. SCALE	25
4. IDLE PERIODS	25
5. INTERNAL PARTS	25
VI. MAINTENANCE	26
1. MAINTENANCE	26
1.1. Brief troubleshooting guide	26
1.2. Maintenance schedule	26

IB. TECHNICAL DATA AND GAS NOZZLE TABLES

TABLE A - Gas appliance technical data and supply pressures

MODELS		200396 (+CP/G1U) 1/2M	200372 (+CP/G1RU) 1/2M Rapid System	200397 (+CP/G2U) 1M	200373 (+CP/G2RU) 1M Rapid System
Power supply voltage	V	120/208	208	208	208
Electrical power absorbed	kW	0.03	2,5	0,05	5
Phases	Nr.	1	3	1	3
Frequency	Hz	60	60	60	60
Power supply cable section 4 wires cable type SJO (minimum 60°C cable)	AWG	14	16	14	12
Gas connection	Ø	1/2"	1/2"	1/2"	1/2"
Burners	No.	1	1	2	2
Nominal heat output	kW	15,5	15,5	31	31
	Btu/h	53000	53000	106000	106000
Natural gas supply pressure	mbar	10	10	10	10
	"w .c.	4	4	4	4
Propane gas supply pressure	mbar	25	25	25	25
	"w .c.	10	10	10	10

TABLE B – Burner nozzle, pilot and sleeve opening

GAS type	MAX nozzle		AERATOR opening (mm)	Pilot (No.)
	mm	Stamping		
Natural Gas	3,30	330	24	25
Propane	2,15	215	28	24

TABLE C - Electric appliance technical data

MODELS		200398 (+CP/E1U) 1/2M	200374 (+CP/E1RU) 1/2M Rapid System	200399 (+CP/E2U) 1M	200375 (+CP/E2RU) 1M Rapid System	200400 (+CP/E1TU) 1/2M Timer Buzzer
Power supply voltage	V	208	208	208	208	208
Phases	Nr.	3	3	3	3	3
Frequency	Hz	60	60	60	60	60
Max. total power	kW	10	13	20	26	10
Power supply cable section 4 wires cable type SJO (minimum 75°C cable)	AWG	8	8	4	4	-

ELECTROLUX PROFESSIONAL RESERVES THE RIGHT TO CHANGE SPECIFICATIONS AND PRODUCT DESIGN WITHOUT NOTICE. SUCH REVISIONS DO NOT ENTITLE THE BUYER TO CORRESPONDING CHANGES, ADDITIONS, OR REPLACEMENTS FOR PREVIOUSLY PURCHASED EQUIPMENT.

II. GENERAL INFORMATION

1. INSTRUCTIONS

- Read this manual carefully before using the appliance.
- After installation keep the manual for future consultation.
- This manual contains instructions for various appliances. See the appliance dataplate positioned under the control panel in order to identify the appliance product code.
- The following terms alert you to potentially dangerous conditions to the operator, service personnel or to the equipment.
- **Danger!** This term warns of immediate hazards which will result in severe injury or death.
- **Warning!** This term refers to a potential hazard or unsafe practice which could result in injury or death.
- **Notice.** This term refers to information that needs special attention or must be fully understood, even though not dangerous.
- Keep the appliance area free and clear from combustibles.

Warning Fire hazard.

For your safety, do not store or use gasoline or other flammable, vapors and liquids in the vicinity of this or any other appliance.

Keep area around appliances free and clear of combustibles

Warning!

Asphyxiation can result from improper ventilation. Do not obstruct the flow of combustion and ventilation air to and from your cooking equipment

- **Only install the appliance in well-ventilated places. Inadequate ventilation causes asphyxia. Do not obstruct the ventilation system of the place where the appliance is installed. Do not obstruct the vents or ducts of this or other appliances.**
- **Affix emergency telephone numbers in a visible position.**

Important: Installation and maintenance of the appliance and its conversion to a different gas supply, must only be performed by a qualified installer authorised by the manufacturer.

- **For assistance, contact an authorized service centre. Demand original spare parts.**
- This appliance is designed for the cooking of foodstuffs. It is intended for industrial use. Any other use is **considered improper.**
- **Personnel using the appliance must be trained. Do not leave the appliance unattended when operating.**
- Turn off the appliance in case of fault or poor operation.

- Do not use (even if diluted) products containing chlorine (sodium hypochlorite, hydrochloric or muriatic acid, etc.) to clean the appliance or the floor under the appliance. Do not use metal tools (wire brushes or Scotch Brite type abrasive scouring pads) to clean steel parts .
- Do not allow oil or fat to come into contact with plastic parts.
- Do not allow dirt, grease, food or other residuals to form deposits on the appliance.
- Do not wash the appliance with direct jets of water.

Failure to observe the above could compromise the safety of the appliance.

Failure to respect the above invalidates the warranty.

2. THE ENVIRONMENT

2.1. PACKING

Packing materials are environment friendly and can be stored without risk, or burned in a special waste incineration plant. Recyclable plastic components are marked with .

PE Polyethylene:

outer wrapping, instruction booklet bag, gas nozzle bag.

pp Polypropylene:

roof packing panels, straps.

PS Polystyrene foam:

corner protectors.

2.2. USE

Our appliances offer high performance and efficiency. To reduce consumption of electricity, water or gas, do not use the appliance empty or in conditions that compromise optimal efficiency (e.g. with doors or lids open, etc.); the appliance must be used in a well-ventilated place, to avoid the creation of dangerous mixtures of unburnt gases in the room. Whenever possible, pre-heat only before use.

2.3. CLEANING

In order to reduce the emission of pollutants into the environment, clean the appliance (externally and when necessary internally) with products which are more than 90% biodegradable (for further information, see chap. V "CLEANING").

2.4. DISPOSAL

Do not disperse in the environment Our appliances are manufactured using more than 90% (in weight) recyclable metals (stainless steel, iron, aluminium, galvanized sheet, copper, etc.

Make the appliance unusable by removing the power supply cable and any door locking mechanisms in order to avoid the risk of someone becoming closed inside.

2.5. RADIO INTERFERENCE

This appliance conforms to Directive EEC 89/336 relevant to the suppression of radio interference.

III. INSTALLATION

1. GUIDELINES

- Installation must be carried out by professionally qualified personnel in full compliance with current laws and safety regulations.
- The electrical connection must be carried out in conformity with the current local safety regulations.
- This equipment is to be installed to comply with the applicable federal, state or local codes. These installation procedures must be followed by qualified personnel or warranty will be void. The National Fire Protection Association, Inc states in its NFPA latest edition that local codes are the "authority having jurisdiction" when it comes to installation requirements for equipment. Therefore, installations should comply with all local codes.
- The appliance must be installed with an adequate non-return valve, in conformity with the federal, state and local regulations.

2. UNPACKING

Remove the packing.
Carefully remove the protective film from metal surfaces.
Remove any traces of glue using a suitable solvent.

IMPORTANT! Immediately check for any damage caused during transport.

- Inspect the packs before and after unloading.
- The forwarder is responsible for the safety of the goods during transport and delivery.
- Make a complaint to the forwarder in the event of apparent or hidden damage. Specify any damage or shortages on the dispatch note.
- The driver must sign the dispatch note: the forwarder can reject the claim if the dispatch note is not signed (the forwarder can provide the necessary form).
- For hidden damage or shortages becoming apparent only after unpacking, within and not later 15 days of delivery request the forwarder for inspection of the goods.
- Keep all the documentation contained in the packing.

3. POSITIONING

3.1. GENERAL INFORMATION

- The installation diagrams specify the overall dimensions of the appliance and the positions of connections (water inlet- gas inlet- power cable input).
- Appliances can be installed separately or in combination with other appliances in the same range (see par. 3.3).
- The appliances are not suitable for built-in installation.
- Leave at least 4" / 10 cm between the appliance and side or rear walls.
- Maintain an adequate distance between the appliance and any combustible walls.
- Leave an adequate space between the appliance and any side walls in order to allow subsequent servicing or maintenance operations.
- Suitably insulate any surfaces that are less than the specified distances from the appliance.

3.2. SECURING TO THE FLOOR

To avoid accidental tipping of monobloc half-module appliances installed separately, fix them to the floor. The relative accessory comes with instructions (F206136).

3.3. COMBINING APPLIANCES

- (Fig. 1A) Undo the 4 fixing screws and remove the control panels from appliances.
- (Fig. 1B) Remove the fixing screw nearest the control panel, from each side to be joined.
- (Fig. 1D) Bring the appliances together and level them by turning the feet until the tops of the appliances match.
- (Fig. 1F) From the rear of the appliances, insert the coupling plate supplied into the side housings on the backs. Secure the plate using two M5 flathead screws provided.
- (Fig. 1C) Turn one of the two plates inside the appliances 180°.
- (Fig. 1E) From inside the control panel of the same appliance, join them at the front side, screwing one TE M5x40 screw (supplied) on the opposite insert.

3.4 ASSEMBLY AND JOINING OF COUNTER TOP APPLIANCES ON BASE, OVEN, BRIDGE AND CANTILEVER FRAME

Follow the instructions supplied with the optional product selected.

3.5 SEALING GAPS BETWEEN APPLIANCES

Follow the instructions supplied with the optional sealing paste pack.

4. FUME EXHAUST

4.1. WARNINGS

- Improper ventilation can result in personal injury or death. Ventilation which fails to properly remove flue products can cause headaches, drowsiness, nausea, or could result in death.
- All units must be installed in such a manner that the flow of combustion and ventilation air are not obstructed. Provisions for adequate air supply must be provided.
- Do not obstruct the front of the unit at the top by the control panel, or the bottom just below the oven compartment, as combustion air enters through these areas.
- Any problem due to improper ventilation will not be covered by the warranty.
- Ranges with solid tops, such as griddles or hot tops, must always have venting for their flue products at the rear of their burner compartments provided by the hollow area inside a shelf 21" high or a backsplash 17" high. Lack of sufficient venting for the burners in these compartments will cause poor burner and pilot operating characteristics, resulting in inefficient performance. Such conditions also cause high ambient temperatures at the manifold area and create valve and thermostat problems.
- It is recommended to position the appliances under an extraction hood to ensure the removal of steam and exhaust gases produced during the cooking.
- From the termination of the flue to the filters of the hood venting system, a minimum clearance of 18" (457mm) must be maintained.

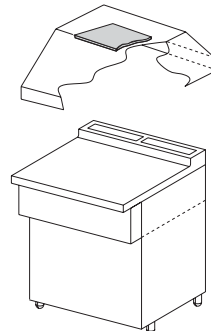

4.2. VENTILATION

- Proper ventilation is highly essential for optimum performance. A strong exhaust will create a vacuum in the room. For an exhaust vent to work properly, replacement air must enter the room.
The amount of air that enters must equal the amount exhausted.
- All gas burners and pilots need sufficient air to operate. Large objects should not be placed in front of the appliance(s) which would obstruct the flow of air into the front.
- The National Fire Protection Association, Inc states in its NFPA latest edition that local codes are the "authority having jurisdiction" when it comes to installation requirements for equipment. Therefore, installations should comply with all local codes.

5. CONNECTIONS

See the appliance dataplate for the appliance product code. See the installation diagrams for the position of connections on the appliance.

- GAS
- ELECTRICITY
- WATER SUPPLY
- WATER DISCHARGE

5.1. GAS APPLIANCES

IMPORTANT! This appliance is designed and approved to operate with G20 gas 10mbar; (4"wc); to convert it to another type of gas, follow the instructions in paragraph 5.1.6. of this chapter.

5.1.1. BEFORE CONNECTION

- Fit a rapid gas shut-off cock ahead of each appliance. Install the cock/valve in an easily accessed place.
- Clean the supply pipes in order to remove any dust, dirt or foreign matter that could block the supply.
- Do not use supply pipes of a diameter smaller than that for which the appliance is designed.
- Fit a rapid gas shut-off cock ahead of each appliance in an easily accessed place.
- After installation, use soapy water to check connections for leaks.
- Make sure that the appliance is arranged for the type of gas to be used. Otherwise, carefully follow the instructions given in paragraph: "Conversion to a different type of gas".
- In addition to installation, any maintenance operation (gas, electricity) must only be carried out by the utility company or an authorized installation technician.

5.1.2. CONNECTION

- The appliance is arranged for connection on the bottom right hand side (Fig. 4A - point G).
- Before connecting the appliance to the gas supply, remove the protective plastic cover from the appliance gas connection.
- The appliance is provided with a second gas connection on the rear right hand side. To use this connection, unscrew the metal plug, screw it onto the lower inlet and connect to the mains gas.

5.1.3. SUPPLY PRESSURE CHECK

Make sure the appliance is suitable for the type of gas available, according to what is shown on the dataplate (otherwise, follow the instructions given in the section "**Conversion to another type of gas**"). The supply pressure must be measured with the appliance operating, using a manometer (min. 0.1 mbar).

The pressure regulator must be set at 4" w.c. (10 mbar) for natural gas and 10" w.c. (25 mbar) for propane gas. To check the pressure, proceed as follows:

- 1) Turn all thermostats and burner cocks to the OFF position.
- 2) Close the main gas cock ahead of the appliance.
- 3) Remove the knobs and control panel and locate pressure point "N" on the valve (fig. 2A).
- 4) Remove the sealing screw from the pressure point and connect a manometer "O" (fig. 2A).
- 5) Open the gas cock ahead of the appliance.
- 6) Light the pilot flames and burners, then read the pressure on the gauge (to light the pilot flames and burners refer to par.1.2 in part IV "**User instructions**"), then compare the value read on the manometer with that given in following table:

		Nom.	Min.	Max
Natural gas	mbar	10	8,7	26,1
	"w.c.	4	3,5	10,5
Propane	mbar	25	19,9	32,3
	"w.c.	10	8	13

- 7) If the supply pressure does **not** come within the minimum and maximum values provided for, immediately inform the gas company and adjust the appliance inlet pressure (operating pressure regulator "B" - fig. on previous page) as indicated in points 8, 9 and 10.

DO NOT operate the appliance before adjusting the pressure to the nominal value specified in the table.

If the supply pressure is already at the nominal value, go to step 11.

- 8) Unscrew the regulator cover.
- 9) If the appliance is fed with PROPANE, remove the adjustment screw and replace the spring (on the inside) with the BLUE one supplied. Then refit the adjustment screw.
- 10) Using a screwdriver, turn the adjustment screw (on the inside) clockwise to increase or anticlockwise to decrease the pressure until obtaining the correct level.
- 11) Refit the regulator cover.
- 12) Repeat steps 1 and 2.
- 13) Remove the manometer and refit the sealing screw.
- 14) Refit the control panel and knobs.

5.1.4 GAS PRESSURE REGULATOR

- The section of the gas supply line must be sufficient to ensure the gas flow necessary for **full operation** of all the units connected to the system.
- The gas pressure regulator and quick shutoff cock, both supplied with the appliance inside a plastic bag, must be installed ahead of the appliance.
- The following figure shows how to fit the cock and regulator:
 - "A" connection side - gas towards the appliance;
 - "B" pressure regulator (3.3"x2.9"x2.7" / 85x75x71mm);
 - "C" gas quick shutoff cock;
 - "D" connection side - gas from mains.

- Use the same diameter union between the gas supply and cock "C".

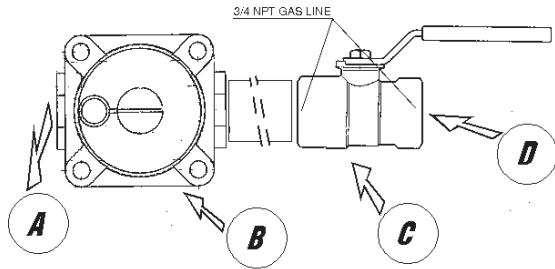

- The arrow on the regulator shows the gas flow direction. The pressure regulator should preferably be fitted horizontally, to ensure the right outlet pressure.
- These models are designed and certified for use with natural or propane gas. For natural gas, the pressure regulator on the manifold is set at 4" w.c. (10 mbar).

5.1.5. SUPPLY PRESSURE ADJUSTMENT

Make sure the appliance is suitable for the type of gas, according to what is shown on the dataplate. Otherwise follow the indications given in the section: "**Conversion to another type of gas**".

The pressure regulator must be set at 4" w.c. (10 mbar) for natural gas and 10" w.c. (25 mbar) for propane gas. To check the pressure, proceed as follows:

- 1) Turn all thermostats and burner cocks to the OFF position.
- 2) Close the main gas cock ahead of the appliance.
- 3) Remove the knobs and control panel and locate pressure point "A" on the gas feed pipe.
- 4) Remove the sealing screw from the pressure point and connect a manometer.
- 5) Open the gas cock ahead of the appliance.
- 6) Light all the pilot and main burners (and oven if present), then read the pressure value on the gauge (to light the pilot flames and burners refer to par 1.2 in part IV "**User instructions**").
- 7) If the supply pressure does **not** come within the minimum and maximum values provided for, immediately inform the gas company and adjust the appliance inlet pressure (operating pressure regulator "B" - fig. 5) as indicated in points 8, 9 and 10. **DO NOT** operate the appliance before adjusting the pressure to the nominal value specified in the table. If the supply pressure is already at the nominal value (see the following table), go to step 11.
- 8) Unscrew the regulator cover.
- 9) If the appliance is fed with PROPANE, remove the adjustment screw and replace the spring (on the inside) with the BLUE one supplied. Then refit the adjustment screw.
- 10) Using a screwdriver, turn the adjustment screw (on the inside) clockwise to increase or anticlockwise to decrease the pressure until obtaining the correct level.
- 11) Refit the regulator cover.
- 12) Repeat steps 1 and 2.
- 13) Remove the manometer and refit the sealing screw.
- 14) Refit the control panel and knobs.

5.1.6 PRIMARY AIR CONTROL

The primary air supply is correctly adjusted when the flame does not detach with the burner cold and there is no flareback with burner hot.

- Undo screw "A" and position aerator "E" at distance "H" shown in table B; retighten screw "A" and seal with paint (fig. 3A).

5.1.7. CONVERSION TO ANOTHER TYPE OF GAS

Table B "technical data/gas nozzles" shows the type of nozzles to be used when replacing those installed by the manufacturer (the number is stamped on the nozzle body). At the end of the procedure, carry out the following check-list:

Check	Ok
• burner nozzle/s replacement	
• correct adjustment of primary air supply to burner/s	
• pilot nozzle/s replacement	
• minimum flame screw/s replacement	
• correct adjustment pilot/s if necessary	
• correct adjustment of supply pressure (see technical data/gas nozzles table)	
• apply sticker (supplied) on the appliance, with data of new gas type used	
• apply sticker (supplied) on the pressure regulator, with data of new gas type used	

5.1.7.1 REPLACING THE MAIN BURNER NOZZLE (fig.3A)

- Loosen screw "A" and unscrew nozzle "C".
- Remove the nozzle and aerator.
- Replace nozzle "C" with one suitable for the type of gas, according to what is shown in table B.
- The nozzle diameter is shown in hundredths of mm on the nozzle body.
- Insert nozzle "C" in aerator "E", then fit the two assembled components in their position and screw the nozzle down.

5.1.7.2 REPLACING THE PILOT BURNER NOZZLE

- Unscrew nipple "A" and replace nozzle "B" with the one suitable for the type of gas (Table B, fig.3B).
- The nozzle number is shown on the nozzle body.
- Retighten nipple "A".

5.1.7.3 VALVE GAS CONVERSION KIT USE

- Remove protection cap "A", adjustment screw "B" and spring "C" (fig. 4A)
- Fit the adjustment screw and spring included in the conversion kit.
- Set the outlet pressure by turning the adjustment screw "B" (turning it clockwise increases the pressure).
- Fit the new protection cap (red for LPG).
- Place the new label (included in the kit) on the valve body.

5.2. ELECTRIC APPLIANCES

5.2.1. ELECTRICAL CONNECTION (Fig. 4A).

IMPORTANT! Before connecting, make sure the mains voltage and frequency match what is shown on the dataplate.

- The power cable must be flexible, having characteristics at least equal to the type with rubber insulation, and be protected by a metal or rigid plastic pipe. Use an AWG power cable suitable for 75°C for the electrical connection.
- It is necessary to access the terminal block remove the appliance control panel by undoing the fixing screws located under the panel.
- Connect the power cable to the terminal block, as shown in the wiring diagram attached to the appliance.
- Secure the power cable with the cable gland.

IMPORTANT! The manufacturer declines any liability if the accident-prevention regulations are not respected.

5.2.2. CIRCUIT BREAKER

Install a circuit breaker ahead of the appliance. The contact opening distance and maximum leakage current must comply with the current regulations.

5.3. EQUIPOTENTIAL NODE AND EARTH CONNECTION

Connect the appliance to an earth; it must be included in an equipotential node by means of the screw located at the front right under the frame. The screw is marked with the symbol .

5.4. CONNECTION TO THE MAINS FOR MODELS WITH VOLTAGE CHANGE

Configuration 120 Volt 60Hz:

- Turn the switch A1 to 120Volt
- Connect the appliance by means of the terminals L1-N-GND

Configuration 208 Volt 60Hz:

- Turn the switch A1 to 208Volt
- Connect the appliance by means of the terminals L1-L2-GND

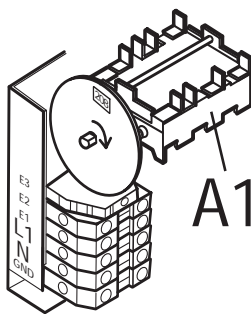

6. WATER SUPPLY CONNECTION

The appliance must be fed with drinking water at a pressure of 150-300 KPa (1.5 - 3 bar).

Important! If the water pressure is higher than that specified, use a pressure reducer to avoid damaging the appliance. For correct installation, water inlet pipe "C" (fig.4A) must be connected to the supply system using a mechanical filter and a shutoff cock. Before connecting the filter, allow a certain amount of water to flow in order to clear the pipe of any waste matter.

7. DRAIN

Discharge water must be removed by means of a suitable receptacle resistant to a temperature of at least 100°C. The steam produced during the discharge phases must not involve the appliance (fig.4A - point S).

8. BEFORE COMPLETING THE INSTALLATION OPERATIONS

Use soapy water to check all gas connections for leaks. DO NOT use a naked flame to check for gas leaks. Light all the burners individually and also together, to check correct operation of the gas valves, rings and lighting. For each burner, adjust the flame regulator to the lowest setting, individually and together; after completing the operations, the installer must instruct the user on the correct method of use. If the appliance does not work properly after carrying out all the checks, contact the local after-sales service.

IV USER INSTRUCTIONS

1. PASTA COOKER USE

- The appliance is intended for industrial use and must be used by personnel trained for the purpose.
- This appliance must only be used for its specifically intended purpose; i.e. for cooking foods such as pasta, rice and similar products in water .
- Do not use the appliance empty or in conditions that compromise its optimum efficiency. Also, if possible, pre-heat the appliance immediately before use.

1.1. WATER FILLING

- Turn on the automatic switch installed ahead of the appliance and open the water tap.
- Close water discharge valve “S”;
- To fill **with water** operate selection knob “C”. There are 3 positions:
 - “0” : Electrical power off (green indicator light “L” off);
 - “1” : Rapid water filling (from tube “T”);
 - “2” : Stopping of water filling and enabling for heating tank;
 - “3” : Slow water filling (water heated for Rapid System pasta cookers) and enabling for heating tank;
- The overflow pipe “M” guarantees control of the maximum water filling level and allows removal of cooking froth.

N.B.: use of slow water filling (position “3”) guarantees constant replacement of the water evaporated or absorbed by the food during cooking in case of continuous use of the appliance.

IMPORTANT! Always make sure that the water level inside the tank is correct, restoring the optimum level if necessary. (the min. level for cooking is indicated by the reference notch). If the water level is well below minimum, the heating function may not switch on or off during cooking.

1.2. GAS MODELS

The burner ignition knob “V” (on front panel) has 3 positions:

- off
- ★ pilot on
- 🔥 flame

Ignition

- Press and turn knob “V” to “pilot on”.
- Press the knob down fully to activate the electric igniter and light the pilot.
- Release the knob a little to deactivate lighting, keeping it pressed for about 20 seconds; on releasing it, the pilot flame must remain lit. If it does not, repeat the operation.
- To light the main burner, turn the knob from “pilot on” to “flame” (lighting of the burner is controlled by power regulator “R”, see 1.4).

Switching off

- Press knob “V” lightly and turn it from “flame” to “pilot on” to keep the pilot flame lit for subsequent cooking;
- Press knob “V” lightly and turn it to “off” to switch off the appliance;

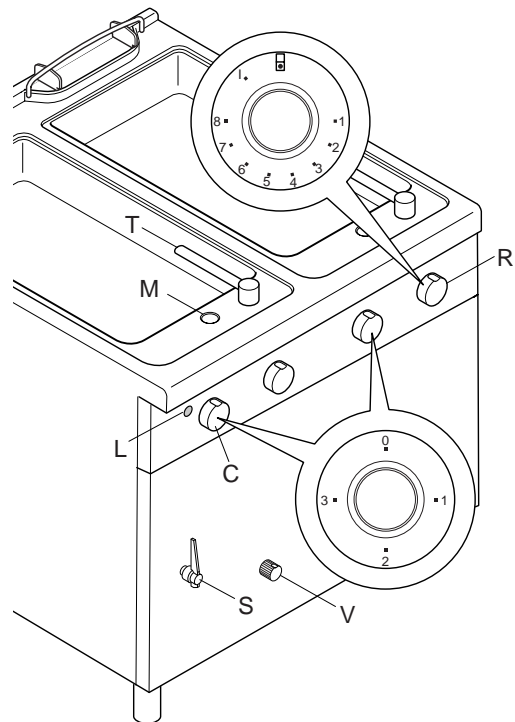

1.3. ELECTRIC MODELS

- Switch on the appliance by turning knob “C” to “2” or “3” (see 1.1). Heating of the elements is controlled by power regulator “R” (see 1.4).

Switching off

- To switch off the appliance, turn knob “C” to “0”.

1.4. COOKING (gas and electric models)

Boiling intensity can be set with power regulator "R".

The positions available are:

- ☐ : Tank heating off;
- 1...5 : low - medium power;
- 6...8 : medium - high;
- I : maximum power;

- Fill the water tank;
- Turn knob "C" to "2" or "3".
- Light the burner (gas versions);
- Turn knob "R" to the desired setting;
- When boiling, add salt (in order to prevent corrosive deposits on the bottom of the tank make sure to use refined salt and if this is not possible dissolve it in water in a separate container).
- Introduce the baskets with food to be cooked in the tank.
- Operate knob "R" adjusting the tank heat according to the quantity and quality of food to be cooked.

N.B.: the choice of a different power level to "I" involves turning tank heating off and on again. On a visual level there may be a variation in boiling of the water without affecting cooking, guaranteeing energy-saving.

- When cooking is over, turn off the power supply by turning knobs "C" and "R" to the Off position, switch off the pilot burner (only for gas versions).

1.5. WATER DISCHARGE

After cooking, empty the water tank by operating discharge lever "S" to reduce the possibility of corrosive deposits inside the tank.

CAUTION! It is advisable to carry out this operation after allowing the machine to cool (the inertia of heating, even if switched off, can damage the tank if empty). If this is not possible, fill the tank with cold water at the same time during the cooking water discharge phase.

1.6. MODELS WITH INSTANTANEOUS HEATER

The "Rapid System" pasta cooker has a 2.8kW rapid boiler without storage, that provides hotter water (about 40 degrees higher than the normal inlet water temperature) in the slow water filling phase (knob "C" in position "3").

This guarantees a lower impact with the temperature of the water already present in tank, better energy-saving and shorter time in bringing to boil.

1.7. MODEL WITH COOKING TIMER ACOUSTIC SIGNAL

- Set the cooking time by rotating timer knob "T".
- Press button "D" to start the programmed cooking cycle. At the end of the cooking cycle, the appliance emits a 20-second acoustic signal.
- To repeat the same cycle, do not reset the time, but simply press button "D".

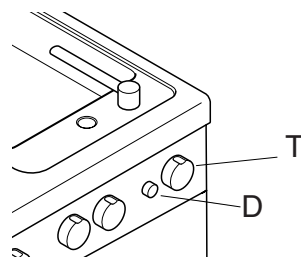

V CLEANING

IMPORTANT!

Before carrying out any cleaning operation, disconnect the appliance from the mains power supply.

1. EXTERNAL PARTS

SATIN FINISH STEEL SURFACES (daily)

- Clean all steel surfaces: dirt is easily removed when just formed.
- Remove dirt, fat and food deposits from steel surfaces when cool, using soapy water, with or without detergent, applied with a cloth or sponge. Dry the surfaces thoroughly after cleaning.
- In the event of stubborn dirt, grease or food deposits, wipe the cloth/sponge with the grain of the satin finish and rinse often: rubbing in a circular motion, combined with the particles of dirt deposited on the cloth/sponge, could damage the steel's satin finish.
- Iron objects could ruin or damage the steel: damaged surfaces become dirty more easily and are more liable to corrode.
- Have the satin finish repaired if necessary.

SURFACES BLACKENED BY HEAT (when necessary)

Exposure to high temperatures can cause the formation of dark marks. These do not constitute damage and can be removed by following the instructions in the previous paragraph.

2. OTHER SURFACES

HEATED TRAYS/CONTAINERS (daily)

Clean the appliance trays or containers using boiled water, adding soda (degreasing) if necessary. Use the accessories (optional or supplied) specified in the list to eliminate encrustations or food deposits.

CAUTION - With electric appliances, make sure no water comes into contact with electric components: water penetration can cause short circuiting and dispersion, tripping the appliance's protection devices.

3. SCALE

STEEL SURFACES (when necessary)

Remove any scale (stains or marks) left by hard water on steel surfaces using suitable detergents, natural (e.g. vinegar) or chemical (e.g. "STRIPAWAY" produced by ECOLAB).

HOT WATER TANKS (at least once a month)

Descale the parts used for water storage and heating by filling them with a solution of chemical detergent (1/3) and water (2/3), carrying out the following procedure:

- Connect a rubber hose to the boiler drain, on the bottom of the unit, ensuring that it is tight;
- Open the drain valve under the bottom, and empty the boiler;
- With the valve open, add the scale remover via the rubber hose, until the liquid comes out the dispenser spout on the shelf;
- Close the valve, keeping the hose lifted;
- After letting it drip for a few seconds, allow the scale remover to work (at least a couple of hours);
- Empty the boiler;
- Close the valve and do a wash cycle with the tank drain open and fast fill on, for at least 5 minutes.

4. IDLE PERIODS

If the appliance is not going to be used for some time, take the following precautions:

- Close any cocks or main switches installed ahead of the appliance.
- Rub stainless steel surfaces vigorously with a cloth moistened with vaseline oil in order to form a protective film.
- Periodically air the premises.
- Have the appliance checked before using it again.
- In order to avoid too rapid evaporation of accumulated moisture and consequent breakage of the element, when starting up again leave electric appliances on minimum power setting for at least 45 minutes.

5. INTERNAL PARTS

(every 6 months)

IMPORTANT! Operations to be carried out exclusively by specialized technicians.

- Check the condition of internal parts.
- Remove any deposits of dirt from inside the appliance
- Inspect and clean the flue system.

N.B.: in certain ambient conditions (e.g. **intensive** use of the appliance, salty environment, etc.) the cleaning should be more frequent.

VI MAINTENANCE

1. MAINTENANCE

All the components requiring maintenance are accessible from the front of the appliance, after removing the control panel and front panel. Disconnect the electrical power supply before opening the appliance

1.1 BRIEF TROUBLESHOOTING GUIDE

Even with correct use, malfunctions can occur.

- *The pilot burner does not light.*

Possible causes:

- The igniter is not properly fixed or is incorrectly connected,
- The ignition or the igniter cable are damaged.
- Insufficient pressure in gas pipes,
- Nozzle blocked,
- Faulty gas valve;

- *The pilot burner goes out.*

Possible causes:

- The pilot burner is not heating the thermocouple sufficiently.
- The control knob of the gas cock and/or gas valve is not being pressed enough,
- Lack of gas pressure at the valve,
- Faulty gas valve.

- *The main burner does not light*

Possible causes:

- Loss of pressure in gas supply pipe
- Blocked nozzle or faulty gas valve
- Gas outlet holes on burner clogged.

INSTRUCTIONS FOR REPLACING COMPONENTS (to be carried only by an authorized installer).

Remove the front panel to access the:

GAS VALVE

- Unscrew the pilot and thermocouple pipe, unscrew the gas inlet and outlet connections.
- For installation carry out the same procedure in reverse order.

PILOT BURNER, THERMOCOUPLE, IGNITER ASSEMBLY

- To replace the igniter and thermocouple loosen the fixing screws and remove the components.
- To replace the pilot burner undo the gas pipe, remove the pilot burner assembly
- Replace the components proceeding in reverse order to refit the parts.

MAIN BURNER

- Unscrew the gas connection from the nozzle holder
- Undo the screws fixing the burner to the support
- Remove the pilot burner assembly by undoing the screws
- For installation carry out the same procedure in reverse order, making sure that when positioning the burner the centering pins, located at the back of the burner, enter their special seats.

REPLACING HEATING ELEMENTS "RAPID SYSTEM" VERSION

- To access the heating elements of the rapid system, remove the front panel, disconnect the elements from the power supply wires and undo the fixing screws.
- For installation carry out the same procedure in reverse order.

1.2 MAINTENANCE SCHEDULE

- It is recommended the appliance is inspected and serviced by an authorized person at least every 12 months. For this purpose it is recommended to draw up a maintenance contract.