

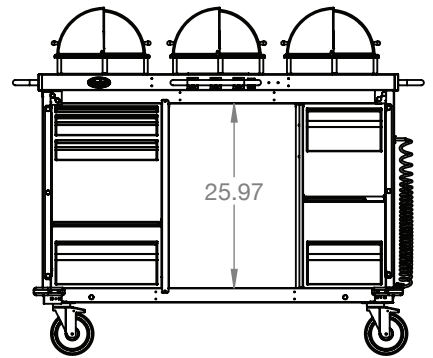

Three Bay Heated Foodservice Cart

Model: CBC-HHH

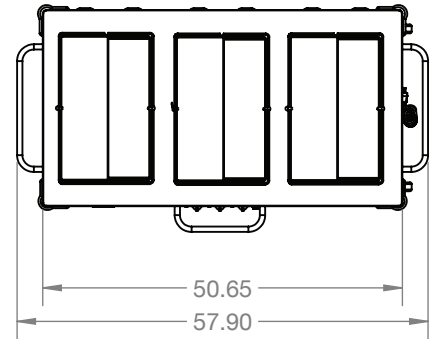

Product Features

- Stainless Steel construction with handles
- Silent casters (2 with locking brakes; 2 with directional locks)
- Laminate finish or stainless steel panels on front/sides of cart
- 3 full size HOT buffet servers: each has 2 half size stainless steam pans, 1 clear Eastman Tritan copolyester rolltop lid with metal hinges & stainless pan holder
- 2 1/2" deep half-size pans hold over (30) 4 oz. servings ea.
- 6 drawers: plating drawer, silverware storage, divided/condiments storage, & cold storage
- 2 shelves (1 for tray storage)
- (2) clear polycarbonate pans, each with Cambro #20PPD drain shelf
- 3 variable heat control knobs (-155° - 205°F)
- 72" long coiled cord
- 120 v / 900w / 7.5 amps
- Rubber bumpers on top and bottom of cart corners
- Warming surface top removable for service
- Space for optional Cambro Camcarrier Hot/Cold Box, Model UPC 40 or UPCH 400 or equivalent
- Freight class 250: Not UPS-able, must ship by truck
- All carts FOB factory (06098)

Warranty: 1 year limited warranty in contiguous US states. 30 days initial defect on laminate panels
UL Safety & Sanitary

Freight Class: 250. Not UPS-able, must ship by truck. F.O.B. 06098.

*Ship weights include shipping skids (approx. 40 lbs. per skid)

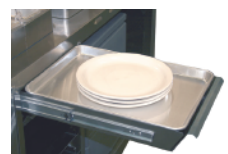
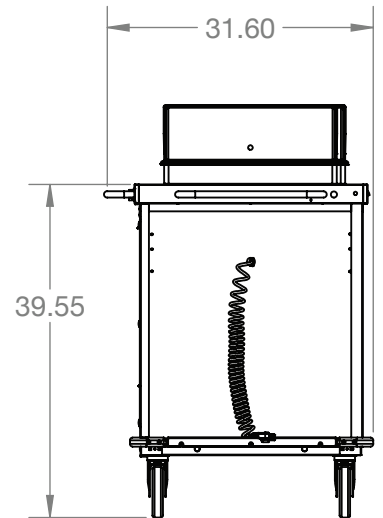

Top plate drawer pulls out to hold tray while plating food

