

BIG BIZ 1 09_2020

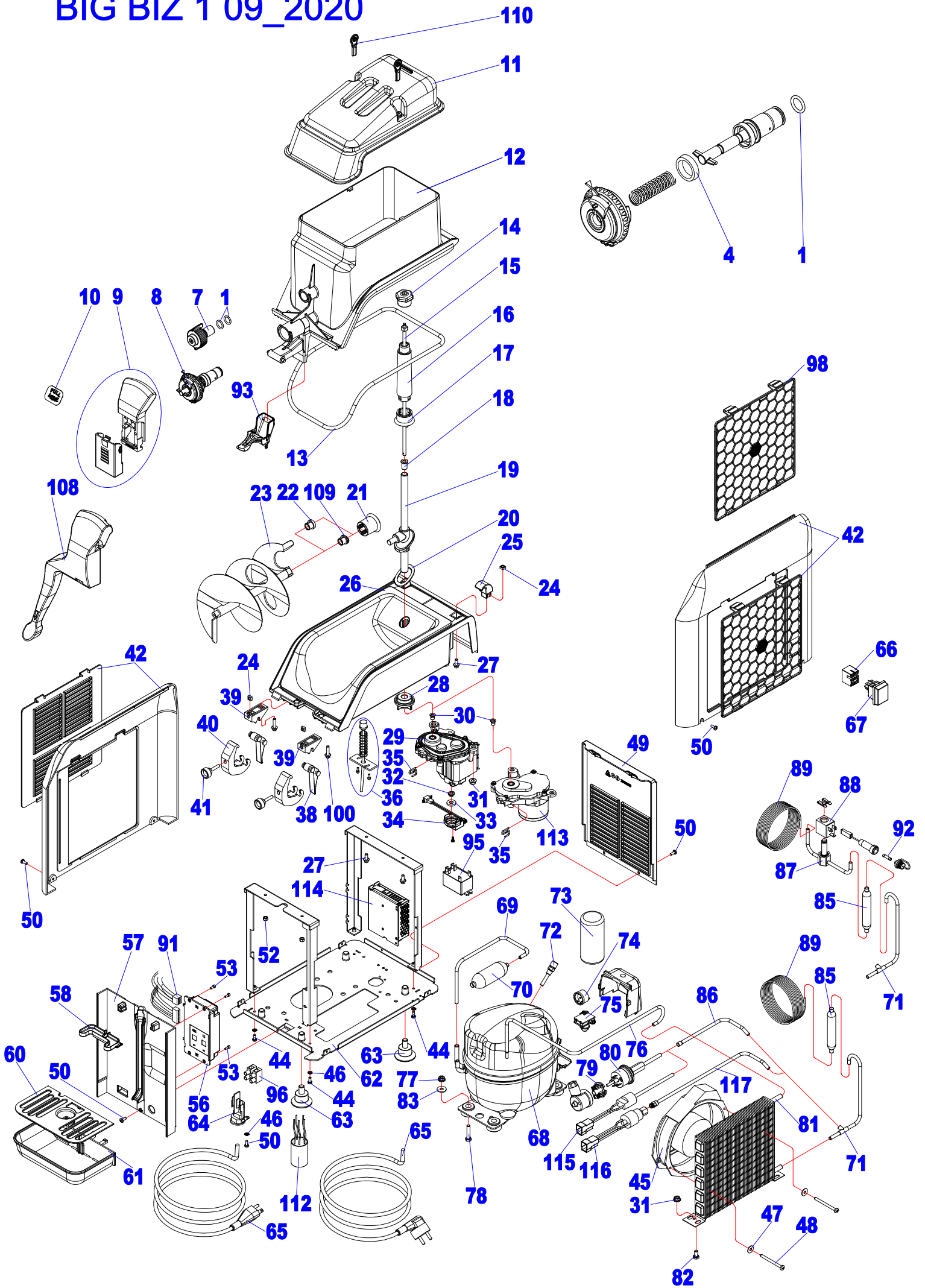

BIG BIZ 2 09_2020

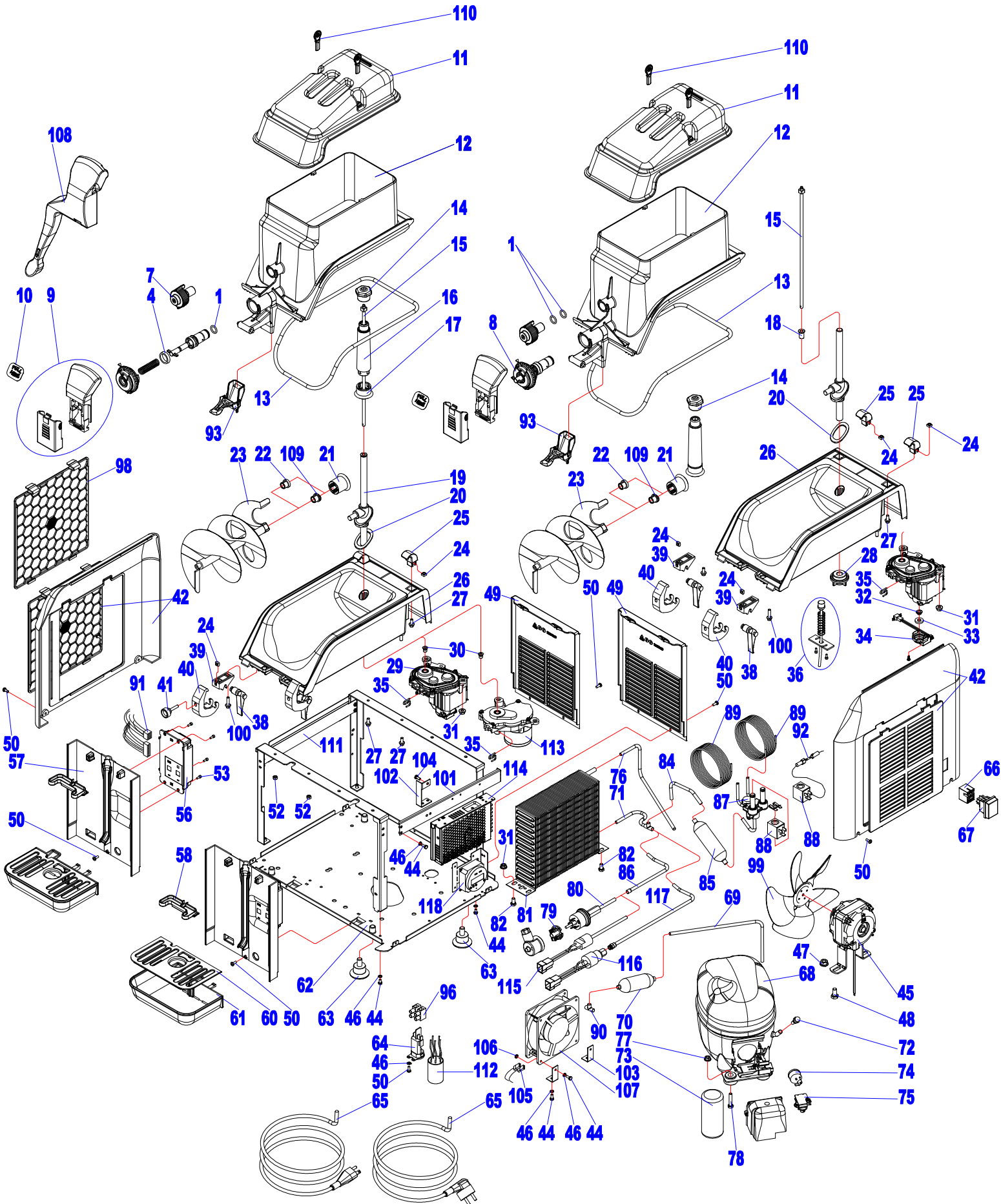

BIG BIZ: Listino Ricambi\Spare Part Price List 2020 Rev.09

BB											
CODICE	ESP.	DESCRIZIONE	DESCRIPTION	VERS.	BB1	BB2	115/ 60	230/ 50	220/ 60	100/ 50- 60	
OR13000117	1	O-RING 117 SILICONE	O-RING 117	ALL	*	*	*	*	*	*	
M0003117-001	4	GUARNIZIONE GOLA RUBINETTO SILICONE	OUTLET BACK GASKET	ALL	*	*	*	*	*	*	
M0004109-002	7	ASSIEME GHIERA-MANICOTTO VERSIONE 2012	RING NUT HORIZONTAL AUGER 2012 VERSION	ALL	*	*	*	*	*	*	
M0003126-001	8	ASSIEME GHIERA-LEVETTA CON PISTONE (ASTINA INOX)	RING NUT LEVER COVER PISTON (STAINLESS STEEL AXE)	ALL	*	*	*	*	*	*	
M0003126-003	8	ASSIEME GHIERA-LEVETTA CON PISTONE VERSIONE 2014 (ASTINA FIBRA VETRO)	RING NUT LEVER COVER PISTON 2014 VERSION (GLASS FIBER)	ALL	*	*	*	*	*	*	
M0003139-001	9	ASSIEME LEVA+COPERCHIO NERO VERSIONE 2012	BLACK HANDLE AND COVER 2012 VERSION	ALL	*	*	*	*	*	*	
A0006111-001	10	ADESIVO "PULL HERE"	"PULL HERE" STICKER	ALL	*	*	*	*	*	*	
L0006104-005	11	CUPOLA TRASPARENTE CON CHIAVI DI BLOCCO	TRANSPARENT TOP LIGHT W/LID LOCK	ALL	*	*	*	*	*	*	
L0000115-003	12	VASCA TRASPARENTE VERSIONE 2017 w/lid lock	TRANSPARENT TANK 2017 VERSION w/lid lock	ALL	*	*	*	*	*	*	
L0000106-001	13	GUARNIZIONE PER VASCA	GASKET TRANSPARENT TANK	ALL	*	*	*	*	*	*	
M0000107-001	14	GHIERA FISSAGGIO ELICA VERTICALE	RING NUT VERTICAL PROPELLER	ALL	*	*	*	*	*	*	
L0000104-001	15	ALBERO TRASMISSIONE CON DADO	TRANSMISSION SHAFT WITH NUT	ALL	*	*	*	*	*	*	
L0004104-001	16	ELICA VERTICALE COMPLETA DI BOCCOLA INOX	VERTICAL AUGER COMPLETE OF BUSHING	ALL	*	*	*	*	*	*	
M0004104-001	17	PIGNONE ELICA VERTICALE FINO A MATRICOLA 140703180	PINION VERTICAL AUGER UNTIL S/N 140703180	ALL	*	*	*	*	*	*	
M0004104-002	17	PIGNONE ELICA VERTICALE A PARTIRE DALLA MATRICOLA 140703181	PINION VERTICAL AUGER FROM S/N 140703181	ALL	*	*	*	*	*	*	
M0000104-001	18	BOCCOLA CANOTTO TRASMISSIONE	BUSHING TRANSMISSION SHAFT	ALL	*	*	*	*	*	*	
L0000116-002	19	KIT CANOTTO TRASMISSIONE COMPLETO BOCCOLA+O-RING VERSIONE 2014	TRANSMISSION SHAFT WITH SLEEVE+ORING 2014 VERSION	ALL	*	*	*	*	*	*	
M0000114-001	20	GUARNIZIONE CANOTTO TRASMISSIONE	TRANSMISSION SHAFT GASKET	ALL	*	*	*	*	*	*	
A0000114-001	20	GUARNIZIONE O-RING CANOTTO TRASMISSIONE VERSIONE 2012	TRANSMISSION SHAFT ORING 2012 VERSION	ALL	*	*	*	*	*	*	
M0004105-002	21	PIGNONE ELICA ORIZZONTALE	HORIZONTAL AUGER GEAR	ALL	*	*	*	*	*	*	
M0004102-002	22	BOCCOLA ELICA ORIZZONTALE VERS. 2012	HORIZONTAL AUGER BUSHING 2012 VERS.	ALL	*	*	*	*	*	*	
L0004103-002	23	ELICA ORIZZONTALE COMPLETA DI BOCCOLA VERS. 2012	HORIZONTAL AUGER COMPLETE OF BUSHING 2012 VERS.	ALL	*	*	*	*	*	*	
M0000120-001	24	DADO QUADRO M5 ZINCATO	M5 SQUARE NUT	ALL	*	*	*	*	*	*	
M0006103-003	25	CERNIERA POSTERIORE NERO	BLACK REAR HINGE	ALL	*	*	*	*	*	*	
L0002113-004	26	ASSIEME VASCA COMPLETA NERO NUOVA SERPENTINA RETTANGOLARE	BIG BIZ COMPLETE BLACK TANK NEW EVAPORATOR	ALL	*	*	*	*	*	*	
M0001101-001	27	VITE TE FLANGIATA M5X12MM	SCREW TE 5X12MM	ALL	*	*	*	*	*	*	
M0000105-001	28	GHIERA FISSAGGIO CANOTTO	RING NUT SHAFT FASTENING	ALL	*	*	*	*	*	*	
M0005139-002	29	ASSIEME MOTORIDUTTORE CON CELLA DI HALL ELCO	COMPLETE GEAR MOTOR WITH HALL SENSOR ELCO	R404A	*	*	*	*	*	*	

BIG BIZ: Listino Ricambi\Spare Part Price List 2020 Rev.09

BB											
CODICE	ESP.	DESCRIZIONE	DESCRIPTION	VERS.	BB1	BB2	115/ 60	230/ 50	220/ 60	100/ 50- 60	
M0005139-003	29	ASSIEME MOTORIDUTTORE CON CELLA DI HALL KENTA	COMPLETE GEAR MOTOR WITH HALL SENSOR KENTA	R404A	*	*	*	*	*	*	
A0000117-001	30	BOCCOLA CENTRAGGIO MOTORID./ALBERO	GEAR MOTOR BUSHING	R404A	*	*	*	*	*	*	
DADOD.6ZFL	31	DADO M6 FLANGIATO	M6 NUT	ALL	*	*	*	*	*	*	
B1071234	32	BUSSOLA TRASCINAMENTO MAGNETE	MAGNET SLEEVE	R404A	*	*	*	*	*	*	
M1551004	33	MAGNETE PERMANENTE	PERMANENT MAGNET	R404A	*	*	*	*	*	*	
A0000123-002	34	KIT CONTENITORE COMPLETO DI SCHEDA CELLA HALL ELCO CON FILO	KIT COMPLETE PLASTIC COVER WITH HALL CELL ELCO	R404A	*	*	*	*	*	*	
C025006	34	CELLA HALL KENTA	HALL CELL KENTA	R404A	*	*	*	*	*	*	
A0001104-001	35	SPINA BLOCCAGGIO MOTOR./ALBERO TRASMISSIONE	GEAR MOTOR/TRANSMISSION SHAFT PIN	ALL	*	*	*	*	*	*	
M0000157-002	36	ASSIEME SONDA TERMOSTATO ELETTRONICO FC-BB 2015	FC-BB ELECTRONIC THERMOSTAT PROBE COMPLETE 2015 VERS.	ALL	*	*	*	*	*	*	
M0006115-003	38	CERNIERA ANTERIORE NERO	BLACK FRONT HINGE	ALL	*	*	*	*	*	*	
M0006116-003	39	BASE NERO	BLACK BASE	ALL	*	*	*	*	*	*	
M0006102-003	40	GANCIO CERNIERA NERO	BLACK HINGE HOOK	ALL	*	*	*	*	*	*	
M0006119-001	41	MANOPOLA FISSAGGIO GANCI M5X25mm	LOCKING BOLT	ALL	*	*	*	*	*	*	
L0006131-001	42	KIT FIANCHI DX+SX+FILTRO ARIA+ALETTATURA NERO	KIT PLASTIC PANEL RIGHT+LEFT+AIR FILTER+LOUVER BLACK	ALL	*	*	*	*	*	*	
L0006131-003	42	KIT FIANCHI DX+SX+FILTRO ARIA+ALETTATURA GIALLO	KIT PLASTIC PANEL RIGHT+LEFT+AIR FILTER+LOUVER YELLOW	ALL	*	*	*	*	*	*	
L0006131-004	42	KIT FIANCHI DX+SX+FILTRO ARIA+ALETTATURA BLU	KIT PLASTIC PANEL RIGHT+LEFT+AIR FILTER+LOUVER BLUE	ALL	*	*	*	*	*	*	
L0006131-005	42	KIT FIANCHI DX+SX+FILTRO ARIA+ALETTATURA BIANCO	KIT PLASTIC PANEL RIGHT+LEFT+AIR FILTER+LOUVER WHITE	ALL	*	*	*	*	*	*	
VTTE4X10Z	44	VITE TE 4X10 ZINCATA	SCREW TE 4X10MM	ALL	*	*	*	*	*	*	
LA105101-001	45	MOTOVENTILATORE 17W 115V/50-60HZ	FAN MOTOR 17W 115V/50-60HZ	ALL	*		*			*	
LD105106-001	45	MOTOVENTILATORE FP-108EXM-220 230V 50/60HZ	FAN MOTOR FP-108EXM-220 230V 50/60HZ	ALL	*			*	*		
AD005102-001	45	MOTOVENTILATORE 82CE-2010/77 230V/50-60HZ	FAN MOTOR 82CE-2010/77 230V/50-60HZ	ALL		*		*	*		
A5005101-001	45	MOTOVENTILATORE 82UL-2009/32 115V/60HZ	FAN MOTOR 82UL-2009/32 115V/60HZ	ALL		*	*			*	
ROND.D.4.3EDENT	46	RONDELLA DENTELLATA D.4,3	INDENTED WASHER D.4,3	ALL	*	*	*	*	*	*	
M0000123-001	47	RONDELLA PIANA 5X15	FLAT WASHER 5X15MM	ALL	*		*	*	*	*	
DADOD.8ZFL	47	DADO M8 FLANGIATO	M8 NUT	ALL		*	*	*	*	*	
VTTC4,8X60Z	48	VITE TC 4.8X50MM CROCE	SCREW TC 4.8X50MM	ALL	*		*	*	*	*	
VTTE8X16Z	48	VITE TE 8X16MM	SCREW TE 8X16MM	ALL		*	*	*	*	*	
L0106101-001	49	PANNELLO POSTERIORE ABS V0 NERO CON ALETTATURA	BACK PANEL BLACK PLASTIC WITH LOUVERS	ALL	*	*	*	*	*	*	

BIG BIZ: Listino Ricambi\Spare Part Price List 2020 Rev.09

BB											
CODICE	ESP.	DESCRIZIONE	DESCRIPTION	VERS.	BB1	BB2	115/ 60	230/ 50	220/ 60	100/ 50- 60	
M0006124-001	50	VITE TC 3.9X9.5MM CROCE	SCREW TC 3.9X9.5MM	ALL	*	*	*	*	*	*	
DADOD.5Z	52	DADO M5 ZINCATO	M5 NUT	ALL	*	*	*	*	*	*	
M0000156-001	53	VITE TCEI M3X8MM	SCREW TCEI 3X8MM	ALL	*	*	*	*	*	*	
L0005105-001	56	ELETTRONICA BB 230V STANDARD 2/5/8	ELECTRONIC BOARD 230V REV 01 STANDARD	R404A	*	*		*	*		
L0005105-005	56	ELETTRONICA BB 230V 2/5/8 + DISPLAY TEMPERATURA	ELECTRONIC BOARD 230V REV 04	R404A	*	*		*			
L0005102-001	56	ELETTRONICA COMPLETA 100-115V	ELECTRONIC BOARD 100-115V REV. 01	R404A	*	*	*			*	
L0005105-010	56	ELETTR. BB 24VDC GREEN 2/5/8	ELECTRONIC BOARD 24VDC GREEN 2/5/8	GREEN G404	*	*	*	*	*	*	
L0106102-002	57	PANNELLO FRONTALE ABS V0 NERO VERSIONE 2012	FRONT PANEL BLACK PLASTIC ABS 2012 VERSION	ALL	*	*	*	*	*	*	
A0006115-001	58	CASSETTO RACCOLTA CONDENSA BB VERSIONE 2012	CONDENSATE DRIP TRAY	ALL	*	*	*	*	*	*	
M0006117-001	60	GRIGLIA SGOCCIOLATOIO ABSV0 NERO	BLACK PLASTIC DRIP TRAY ABSV0	ALL	*	*	*	*	*	*	
M0006117-002	60	GRIGLIA SGOCCIOLATOIO SILVER	SILVER STEEL DRIP TRAY	ALL	*	*	*	*	*	*	
M0006110-004	61	SGOCCIOLATOIO CONDENSA NERO	BLACK DRIP TRAY	ALL	*	*	*	*	*	*	
L0101109-001	62	STRUTTURA COMPLETA BIG BIZ 1	BIG BIZ 1 STRUCTURE	ALL	*		*	*	*	*	
L0201108-001	62	STRUTTURA COMPLETA BIG BIZ 2	BIG BIZ 2 STRUCTURE	ALL		*	*	*	*	*	
PAR114-ELGR	63	PIEDINO STANDARD	RUBBER FEET	ALL	*	*	*	*	*	*	
M0005112-001	64	MORSETTIERA PA84/E	CONNECTION FOR SUPPLYING WIRING	ALL	*	*	*	*	*	*	
CAVOAL.UL15ALAV	65	CAVO ALIMENTAZIONE USA 15A/125V 14AWG UL	POWER CORD 115 V U.L. FOR USA	ALL	*	*	*				
C013COD.1373	65	CAVO ALIMENTAZIONE SCHUKO 16A/230V 3x1,5mmq	SCHUKO POWER CORD	ALL	*	*		*	*		
ASS.CAVO-SPINA	65	CAVO ALIMENTAZIONE UK 13A/250VAC 3x1,5mmq	POWER CORD FOR UK	ALL	*	*		*			
AF005101-001	65	CAVO ALIMENTAZIONE JAPAN PSE 15A/125V	POWER CORD 100V PSE JAPAN	ALL	*	*	*			*	
A0005106-001	66	BLOCCHETTO X INTERRUTTORE SERIE 82	MOLEX CONNECTOR FOR MAIN SWITCH	ALL	*	*	*	*	*	*	
I82L2206165	67	INTERRUTTORE GENERALE	MAIN SWITCH	ALL	*	*	*	*	*	*	
L5102103-001	68	COMPRESSORE NEK2117GK 115V/60HZ-100V/50HZ	NEK2117GK 115V/60HZ-100V/50HZ COMPRESSOR	R404A G404	*		*			*	
L2102101-001	68	COMPRESSORE EMT2117GK 220-240V/50HZ	EMT2117GK 220-240V/50HZ COMPRESSOR	R404A G404	*			*			
L3102102-001	68	COMPRESSORE NEK6144GK 208-230V/60HZ	NEK6144GK 208-230V/60HZ COMPRESSOR	R404A G404	*				*		
A5402101-001	68	COMPRESSORE NEK2125GK 115V/60HZ-100V/50HZ	NEK2125GK 115V/60HZ-100V/50HZ COMPRESSOR	R404A G404		*	*			*	
A2402102-001	68	COMPRESSORE EMT2130GK 220-240V/50HZ	EMT2130GK 220-240V/50HZ COMPRESSOR	R404A G404		*		*			

BIG BIZ: Listino Ricambi\Spare Part Price List 2020 Rev.09

BB											
CODICE	ESP.	DESCRIZIONE	DESCRIPTION	VERS.	BB1	BB2	115/ 60	230/ 50	220/ 60	100/ 50- 60	
A3402101-001	68	COMPRESSORE NEK2134GK 208-230V/60HZ	NEK2134GK 208-230V/60HZ	R404A G404		*			*		
A2402103-001	68	COMPRESSORE EMT2130U 220-240 V/50Hz 873AA6264AA	EMT2130U 220-240 V/50Hz 873AA6264AA COMPRESSOR	GREEN	*	*		*			
A5402104-001	68	COMPRESSORE NEK2134U 115/60 862AG71M9AJ	NEK2134U 115/60 862AG71M9AJ COMPRESSOR	GREEN		*	*				
L0102106-001	69	TUBO RAME D.6 BOYLER-COMPRESSORE BB1	BB1 ACCUMULATOR-COMPRESSOR D.6 PLATE PIPE	ALL	*		*	*	*	*	
L0202102-001	69	TUBO RAME D.6 BOYLER-COMPRESSORE BB2	BB2 ACCUMULATOR-COMPRESSOR D.6 PLATE PIPE	ALL		*	*	*	*	*	
M0102112-001	70	BOYLER	ACCUMULATOR	ALL	*	*	*	*	*	*	
L0102112-001	71	ASSIEME TUBI RAME D.6MM CONDENSATORE-TEE- FILTRO BB1	KIT COPPER PIPE D.6MM CONDENSER-CUPPER TEE- FILTER BB1	ALL	*					*	
L0102113-001	71	ASSIEME TUBI RAME D.6MM CONDENSATORE-TEE-TEE- FILTRO BB1	KIT COPPER PIPE D.6MM CONDENSER-CUPPER TEE- CUPPER TEE-FILTER BB1	ALL	*		*				
L0102106-001	71	TUBO RAME D.6MM CONDENSATORE-FILTRO BB1	BB1 ACCUMULATOR-COMPRESSOR D.6 PLATE PIPE	ALL	*			*	*		
L0202106-001	71	ASSIEME TUBI RAME D.6MM CONDENSATORE-TEE BB2	KIT COPPER PIPE D.6MM CONDENSER-CUPPER TEE BB2	ALL		*	*	*	*	*	
A0002110-001	72	VALVOLA DI CARICA+TUBO RAME D.6MM 4CM BB1/2	CHARGE VALVE+ COPPER PIPE D.6MM 4CM BB1/2	ALL	*	*	*	*	*	*	
L3105103-001	73	CONDENSATORE AVVIAMENTO COMPRESSORE NEK6144GK 208-230V/60HZ	START CAPACITOR NEK6144GK 208-230V/60HZ	R404A G404	*				*		
LD105104-001	73	CONDENSATORE AVVIAMENTO COMPRESSORE NB2117GK 200-230V/50HZ 208-230V/60HZ	START CAPACITOR NB2117GK 200-230V/50HZ 208- 230V/60HZ	R404A G404	*			*	*		
L2105104-001	73	CONDENSATORE AVVIAMENTO COMPRESSORE EMT2117GK 220-240V/50HZ	START CAPACITOR EMT2117GK 220-240V/50HZ	R404A G404	*			*			
L5105106-001	73	CONDENSATORE AVVIAMENTO COMPRESSORE NEK2117GK 115V/60HZ-100V/50HZ	START CAPACITOR NEK2117GK 115V/60HZ-100V/50HZ	R404A G404	*		*			*	
L5105103-001	73	CONDENSATORE AVVIAMENTO COMPRESSORE NB2117GK 115V/60HZ-100V/50HZ	START CAPACITOR NB2117GK 115V/60HZ-100V/50HZ	R404A G404	*		*				
A3405103-001	73	CONDENSATORE AVVIAMENTO COMPRESSORE NEK2134GK 208-230V/60HZ	START CAPACITOR NEK2134GK 208-230V/60HZ	R404A G404		*			*		
A2405103-001	73	CONDENSATORE AVVIAMENTO COMPRESSORE EMT2130GK 220-240V/50HZ	START CAPACITOR EMT2130GK 220-240V/50HZ	R404A G404		*		*			
A5405103-001	73	CONDENSATORE AVVIAMENTO COMPRESSORE NEK2125GK 115V/60HZ-100V/50HZ	START CAPACITOR NEK2125GK 115V/60HZ-100V/50HZ	R404A G404		*	*			*	
COND2252096	73	CONDENSATORE AVVIAMENTO COMPRESSORE NE2125GK 115V/60HZ-100V/50HZ	START CAPACITOR NE2125GK 115V/60HZ-100V/50HZ	R404A G404		*	*			*	
A2405106-001	73	CONDENSATORE AVVIAMENTO EMT2130U230VR290 2252345	START CAPACITOR EMT2130U230VR290 2252345	GREEN	*	*		*			

BIG BIZ: Listino Ricambi\Spare Part Price List 2020 Rev.09

BB											
CODICE	ESP.	DESCRIZIONE	DESCRIPTION	VERS.	BB1	BB2	115/ 60	230/ 50	220/ 60	100/ 50- 60	
A5405106-001	73	CONDENSATORE AVVIAMENTO NEK2134U115V R290 2252324	START CAPACITOR NEK2134U115V R290 2252324	GREEN		*	*				
L3105101-001	74	PROTETTORE TERMICO COMPRESSORE NEK6144GK 208-230V/60HZ	THERMAL PROTECTOR NEK6144GK 208-230V/60HZ	R404A G404	*				*		
LD105102-001	74	PROTETTORE TERMICO COMPRESSORE NB2117GK 200-230V/50HZ 208-230V/60HZ	THERMAL PROTECTOR NB2117GK 200-230V/50HZ 208-230V/60HZ	R404A G404	*			*	*		
L2105102-001	74	PROTETTORE TERMICO COMPRESSORE EMT2117GK 220-240V/50HZ	THERMAL PROTECTOR EMT2117GK 220-240V/50HZ	R404A G404	*			*			
L5105104-001	74	PROTETTORE TERMICO COMPRESSORE NEK2117GK 115V/60HZ-100V/50HZ	THERMAL PROTECTOR NEK2117GK 115V/60HZ-100V/50HZ	R404A G404	*		*			*	
L5105101-001	74	PROTETTORE TERMICO COMPRESSORE NB2117GK 115V/60HZ-100V/50HZ	THERMAL PROTECTOR NB2117GK 115V/60HZ-100V/50HZ	R404A G404	*		*				
A3405101-001	74	PROTETTORE TERMICO COMPRESSORE NEK2134GK 208-230V/60HZ	THERMAL PROTECTOR NEK2134GK 208-230V/60HZ	R404A G404		*			*		
A2405102-001	74	PROTETTORE TERMICO COMPRESSORE EMT2130GK 220-240V/50HZ	THERMAL PROTECTOR EMT2130GK 220-240V/50HZ	R404A G404		*		*			
A5405101-001	74	PROTETTORE TERMICO COMPRESSORE NEK2125GK 115V/60HZ-100V/50HZ	THERMAL PROTECTOR NEK2125GK 115V/60HZ-100V/50HZ	R404A G404		*	*			*	
TER2321004	74	PROTETTORE TERMICO COMPRESSORE NE2125GK 115V/60HZ-100V/50HZ	THERMAL PROTECTOR NE2125GK 115V/60HZ-100V/50HZ	R404A G404		*	*			*	
A2405104-001	74	PROTETTORE TERMICO EMT2130U 230V R290 2319137	OLP THERMAL PROTECTOR EMT2130U 230V R290 2319137	GREEN	*	*		*			
A5405104-001	74	PROTETTORE TERMICO NEK2134U 115V R290 2324063	OLP THERMAL PROTECTOR NEK2134U 115V R290 2324063	GREEN		*	*				
L3105102-001	75	RELE' COMPRESSORE NEK6144GK 208-230V/60HZ	RELAY NEK61447GK 208-230V/60HZ	R404A G404	*				*		
LD105103-001	75	RELE' COMPRESSORE NB2117GK 200-230V/50HZ 208-230V/60HZ	RELAY NB2117GK 200-230V/50HZ 208-230V/60HZ	R404A G404	*			*	*		
L2105103-001	75	RELE' COMPRESSORE EMT2117GK 220-240V/50HZ	RELAY EMT2117GK 220-240V/50HZ	R404A G404	*			*			
L5105105-001	75	RELE' COMPRESSORE NEK2117GK 115V/60HZ-100V/50HZ	RELAY NEK2117GK 115V/60HZ-100V/50HZ	R404A G404	*		*			*	
L5105102-001	75	RELE' COMPRESSORE NB2117GK 115V/60HZ-100V/50HZ	RELAY NB2117GK 115V/60HZ-100V/50HZ	R404A G404	*		*				
A3405102-001	75	RELE' COMPRESSORE NEK2134GK 208-230V/60HZ	RELAY NEK2134GK 208-230V/60HZ	R404A G404		*			*		
A2405101-001	75	RELE' COMPRESSORE EMT2130GK 220-240V/50HZ	RELAY EMT2130GK 220-240V/50HZ	R404A G404		*		*			

BIG BIZ: Listino Ricambi\Spare Part Price List 2020 Rev.09

BB											
CODICE	ESP.	DESCRIZIONE	DESCRIPTION	VERS.	BB1	BB2	115/ 60	230/ 50	220/ 60	100/ 50- 60	
A5405102-001	75	RELE' COMPRESSORE NEK2125GK 115V/60HZ-100V/50HZ	RELAY NEK2125GK 115V/60HZ-100V/50HZ	R404A G404		*	*			*	
CLI2283001	75	RELE' COMPRESSORE NE2125GK 115V/60HZ-100V/50HZ	RELAY NE2125GK 115V/60HZ-100V/50HZ	R404A G404		*	*			*	
A2405105-001	75	RELE' EMT2130U 230V R290 2334127	RELAY EMT2130U 230V R290 2334127	GREEN	*	*		*			
A5405105-001	75	RELE' NEK2134U 115V R290 2271155	RELAY NEK2134U 115V R290 2271155	GREEN		*	*				
L0102101-001	76	TUBO RAME D.6MM CONDENSATORE-COMPRESSORE BB1	BB1 CONDENSER COPPER PIPE D.6MM-COMPRESSOR	ALL	*		*	*	*	*	
L0202103-001	76	TUBO RAME D.6MM CONDENSATORE-COMPRESSORE BB2	BB2 CONDENSER COPPER PIPE D.6MM-COMPRESSOR	ALL		*	*	*	*	*	
DADOD.8ZFLAUT	77	DADO M8 FLANGIATO	M8 NUT	ALL	*		*		*	*	
DADOD.8ZFLAUT	77	DADO M8 FLANGIATO	M8 NUT	ALL		*	*	*	*	*	
DADOD.6ZFL	77	DADO M6 FLANGIATO	M6 NUT	ALL	*			*			
VTTE8X35Z	78	VITE TE M8X35MM	SCREW M8X35MM	ALL	*		*		*	*	
VTTE8X35Z	78	VITE TE M8X35MM	SCREW M8X35MM	ALL		*	*	*	*	*	
VTTE6X30	78	VITE TE M6X30MM	SCREW M6X30MM	ALL	*			*		*	
A0005110-001	79	MORSETTIERA PRESSOSTATO 02303611001	PRESSURE SWITCH CONNECTION WIRES	R404A G404	*	*	*	*	*	*	
A0002101-001	80	PRESSOSTATO R404A	R404A PRESSURE SWITCH	R404A G404	*	*	*	*	*	*	
P0202101-001	81	CONDENSATORE ARIA FERRO STFT 12118 BB1	BB1 IRON AIR CONDENSER STFT12118	ALL	*		*	*	*	*	
L0002103-001	81	CONDENSATORE ARIA FERRO STFT12218 BB2	BB2 IRON AIR CONDENSER STFT12218	ALL		*	*	*	*	*	
VTTE6X12Z	82	VITE TE M6X12MM	SCREW TE 6X12MM	ALL	*	*	*	*	*	*	
RONDELLA6X24PIA	83	RONDELLA PIANA 6X18	FLAT WASHER 6X18MM	ALL	*			*		*	
L0202107-001	84	TUBO RAME D.6MM TEE-FILTRO	COPPER PIPE D.6MM TEE-DRYER	ALL		*		*	*	*	
L0202108-001	84	ASSIEME TUBI RAME D.6MM TEE-TEE-FILTRO BB2	KIT COPPER PIPE D.6MM CUPPER TEE-CUPPER TEE-FILTER BB2	ALL		*	*				
L0102108-001	85	FILTRO ESSICCATORE BB1	BB1 DRYER	ALL	*		*	*	*	*	
A0002113-001	85	FILTRO ESSICCATORE BB2	BB2 DRYER	ALL		*	*	*	*	*	
L0102103-001	86	TUBO RAME D.6MM TEE-PRESSOSTATO A0002101-001 o A0002122-002	COPPER PIPE D.6MM TEE-PRESSURE SWITCH A0002101-001 or A0002122-002	ALL	*		*			*	
L0102103-001	86	TUBO RAME D.6MM TEE-PRESSOSTATO A0002101-001 o A0002122-002	COPPER PIPE D.6MM TEE-PRESSURE SWITCH A0002101-001 or A0002122-002	ALL		*	*	*	*	*	
A0102103-002	87	CORPO VALVOLA 1 VIA OLAB NC DN2 K09214-B	OLAB 1 WAY BODY VALVE NC DN2 K09214-B	ALL	*		*	*	*	*	
A0302101-002	87	BLOCCH. 3VIE NC DN1,2 K09122-A OLAB	OLAB 3 WAY BODY VALVE NC DN1,2 K09122-A	ALL		*	*	*	*	*	
AA605101-001	88	BOBINA 5C R04/RP1 100-120/50-60HZ UR CEME	CEME COIL 5C R04/RP1 100-120/50-60HZ UR	ALL		*	*			*	
AD605101-001	88	BOBINA 5C R1T/RP1 208-240V/50-60HZ UR CEME	CEME COIL 5C R1T/RP1 208-240V/50-60HZ UR	ALL		*		*	*		

BIG BIZ: Listino Ricambi\Spare Part Price List 2020 Rev.09

BB											
CODICE	ESP.	DESCRIZIONE	DESCRIPTION	VERS.	BB1	BB2	115/ 60	230/ 50	220/ 60	100/ 50- 60	
AF005102-001	88	BOBINA 100/50-60 CE 6000BH/E1FN OLAB	OLAB COIL 100/50-60 CE 6000BH/E1FN OLAB	ALL		*				*	
AA005102-001	88	BOBINA 120/50-60 UL 11000BH/G6IU-2 OLAB	OLAB COIL 120/50-60 UL 11000BH/G6IU-2 OLAB	ALL	*	*	*				
AD005103-001	88	BOBINA 230/50-60 CE 6000BH/K5FN OLAB	OLAB COIL 230/50-60 CE 6000BH/K5FN OLAB	ALL	*	*		*	*		
P0002110-001	89	CAPILLARE 0,91MMX3700MM BB1	BB1 0,91MMX3700MM CAPILLARY	R404A G404	*		*	*	*		
A0002108-001	89	CAPILLARE 0,91MMX2500MM BB1	BB1 0,91MMX2500MM CAPILLARY	ALL	*					*	
A0002109-001	89	CAPILLARE 0,91MMX5000MM BB2	BB2 0,91MMX5000MM CAPILLARY	ALL		*	*	*	*	*	
TEEDIRAMED6	90	TEE RAME D.6	D.6 CUPPER TEE	ALL		*	*	*	*	*	
L0105101-001	91	IMPIANTO ELETTRICO BIG BIZ 1	BIG BIZ 1 ELECTRIC INSTALLATION	R404A	*		*	*	*	*	
L0105103-001	91	IMPIANTO ELETTRICO BIG BIZ 1 VERSIONE SENZA RELE POTENZA E PRESSOSTATO	BIG BIZ 1 ELECTRIC INSTALLATION	R404A	*			*	*		
L0105104-001	91	IMPIANTO ELETTRICO BIGBIZ1 GREEN	BIG BIZ 1 GREEN ELECTRIC INSTALLATION	GREEN G404	*		*	*	*		
L0205101-001	91	IMPIANTO ELETTRICO BIG BIZ 2	BIG BIZ 2 ELECTRIC INSTALLATION	R404A		*	*	*	*	*	
L0205101-003	91	IMPIANTO ELETTRICO BB2/BL2 GREEN + TIMER	BIG BIZ 2 /BLARGE 2 GREEN ELECTRIC INSTALLATION +TIMER	GREEN G404		*	*	*	*		
A0005103-001	92	FUSIBILE f 5X20MM 315mA RAPIDO	FAST FUSE 315MA 5X20	ALL	*	*	*	*	*	*	
L0003101-002	93	RIDUTTORE BIBITA FREDDA BB 07_2014 X VASCA L0000115-002	ADAPTER FOR COLD DRINK 07_2014	ALL	*	*	*	*	*	*	
AA005101-001	95	RELE DI POTENZA 120V 668281100300	POWER RELAY 120V 668281100300	ALL	*		*			*	
AD005101-001	95	RELE DI POTENZA 240V 668282400300	POWER RELAY 240V 66822400300	ALL	*			*	*		
M0005151-001	96	MORSETTIERA CAVO ALIMENTAZIONE	POWER CORD SCREW TERMINAL BOARD	ALL	*	*	*			*	
A0006113-001	98	FILTRO ARIA NERO	BLACK PLASTIC AIR FILTER	ALL	*	*	*	*	*	*	
A0006113-003	98	FILTRO ARIA GIALLO	YELLOW PLASTIC AIR FILTER	ALL	*	*	*	*	*	*	
A0006113-004	98	FILTRO ARIA BLU	BLUE PLASTIC AIR FILTER	ALL	*	*	*	*	*	*	
A0006113-005	98	FILTRO ARIA BIANCO	WHITE PLASTIC AIR FILTER	ALL	*	*	*	*	*	*	
V4012201M3WBM	99	VENTOLA ALLUMINIO 200/34°	ALUMINUM FAN BLADE 200/34°	ALL		*	*	*	*	*	
A0000115-001	100	VITE TE FLANGIATA M5X20MM	SCREW TE M5X20MM	ALL	*	*	*	*	*	*	
L0001104-002	101	STAFFA RINFORZO STRUTTURA BB2	SUPPORT BRACKET BB2 STRUCTURE	ALL		*				*	
L0201109-001	102	STAFFA FISSAGGIO BLOCCHETTO VALVOLA BB2	FIXING BRACKET BODY VALVE BB2	ALL		*				*	
L0201110-001	103	STAFFA FISSAGGIO MOTOVENTOLA AGGIUNTIVA BB2	FIXING BRACKET FAN MOTOR BB2	ALL		*				*	
VTTE4X10Z	104	VITE BLOCCAGGIO STAFFA CON BLOCCHETTO VALVOLA OLAB	SCREW LOCK BRACKET	ALL		*				*	
L0205103-001	105	KIT IMPIANTO MOTOVENTOLA AGGIUNTIVA BB2	KIT WIRING PER FAN MOTOR BB2	ALL		*				*	
DADOD.4Z	106	DADO M4 ZINCATO	M4 NUT	ALL		*				*	
LA105101-001	107	MOTOVENTILATORE AGGIUNTO 17W 115V/50-60HZ	SECOND FAN MOTOR 17W 115V/50-60HZ	ALL		*				*	

BIG BIZ: Listino Ricambi\Spare Part Price List 2020 Rev.09

BB											
CODICE	ESP.	DESCRIZIONE	DESCRIPTION	VERS.	BB1	BB2	115/ 60	230/ 50	220/ 60	100/ 50- 60	
M0003138-001	108	MANIGLIA DISABILE	HANDLE FOR DISABLE PEOPLE	ALL	*	*	*	*	*	*	
M0004102-001	109	BOCCOLA ELICA ORIZZONTALE fino alla matricola 130602000	HORIZONTAL AUGER BUSHING untill S/N 130602000	ALL	*	*	*	*	*	*	
B0006113-001	110	CHIAVE SBLOCCO CUPOLA	COVER UNLOCK KEY	ALL	*	*	*	*	*	*	
A0201101-001	111	STAFFA PROTEZIONE MOTOVENTILATORE/RINFORZO STRUTTURA BB2	FAN MOTOR PROTECTION SUPPORT/ REINFORCEMENT BB2 STRUCTURE	ALL		*				*	
AF005103-001	112	FILTRO ANTIDISTURBO 20A	20A SUPPRESSOR FILTER	ALL	*	*				*	
A0005122-002	113	MOTORID. BRUSH. X-10487-2 GRANITA	BRUSHLESS GEAR MOTOR	GREEN G404	*	*	*	*	*		
A0105101-001	114	ALIM. SWITHING 100-240/24 LRS 50-24	POWER SWITCHING 100-240/24 LRS 50-24	GREEN G404	*	*	*	*	*		
A0002122-002	115	PRESSOSTATO NSDHA11B13101 R290 LAV.	R290 PRESSURE SWITCH NSDHA11B13101	GREEN	*		*				
A0002122-002	115	PRESSOSTATO NSDHA11B13101 R290 LAV.	R290 PRESSURE SWITCH NSDHA11B13101	GREEN		*	*	*	*		
A0002123-002	116	PRESSOST. NSDHM00D12100 R404A LAV	R404A PRESSURE SWITCH NSDHM00D12100	R404A	*		*				
A0002123-002	116	PRESSOST. NSDHM00D12100 R404A LAV	R404A PRESSURE SWITCH NSDHM00D12100	R404A		*	*	*	*		
L0002115-001	117	TUBO D.6 TEE-PRESS. A0002123-002 BB/BL	COPPER TUBE D.6 TEE-PRES. SWI. A0002123-002 BB/BL	R404A	*	*	*	*			
L0106103-002		IMBALLO BIG BIZ 1									
L0206101-002		IMBALLO BIG BIZ 2									