



HURAKAN

Sandwich and Salad Prep Tables

HKN-SPT60R2

Item #: HKN-SPT60R2/US Project: _____
Qty: _____ Date: _____ Approval: _____



Features

- ✓ Stainless steel construction with self-closing doors.
- ✓ Electronic control for temperature adjustment and food safety.
- ✓ Adjustable shelves and pre-installed heavy-duty casters.

Technical Data

Width	60 1/5 Inches
Depth	29 1/2 Inches
Height	42 3/8 Inches
Power Cord Length	98.4 Inches
Cutting Board Width	27 1/2 Inches
Interior Width	56 3/8 Inches
Right Door Opening Width	26 2/8 Inches
Cutting Board Depth	11 4/8 Inches
Interior Depth	19 7/8 Inches



Instructions and images in this manual are only for reference and may differ from the actual product. Launch the E-Manual.

www.equip.me



Technical Data

Height with Lid Open	46 4/8 Inches
Interior Height	23 4/8 Inches
Work Surface Height	35 1/4 Inches
Amps	4.8
Hertz	60 Hertz
Phase	1 Phase
Voltage	115 Volts
1/6 Size Pan Capacity	16 Pans
1/9 Size Pan Capacity	
Access Type	Doors NUT70NR1
BTU (LBP)	1365 BTU
Capacity	15 cu.ft.
Casters	yes
Compressor Location	Rear Mounted
Compressor Style	Side / Rear Breathing
Construction	Stainless Steel and Aluminum
Door Style	Swing
Door Type	Solid
Hinge Location	left+right
Horsepower	
Individual Shelf Capacity	88 lb.
Number of Doors	2 Doors
Number of Shelves	2 Shelf
Plug Type	NEMA 5-15P
Refrigerant Capacity	4.2 oz.
Refrigerant Type	R290
Refrigeration Type	Air Cooled
Temperature Range	33 - 41 Degrees F
Type	Prep Refrigeration



Plan View

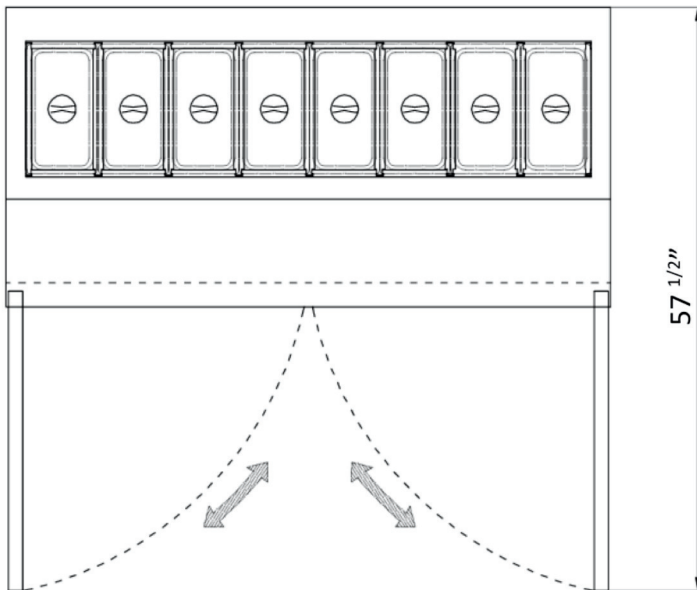
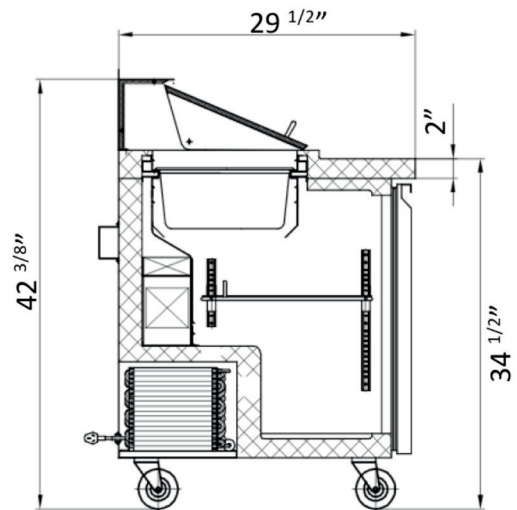
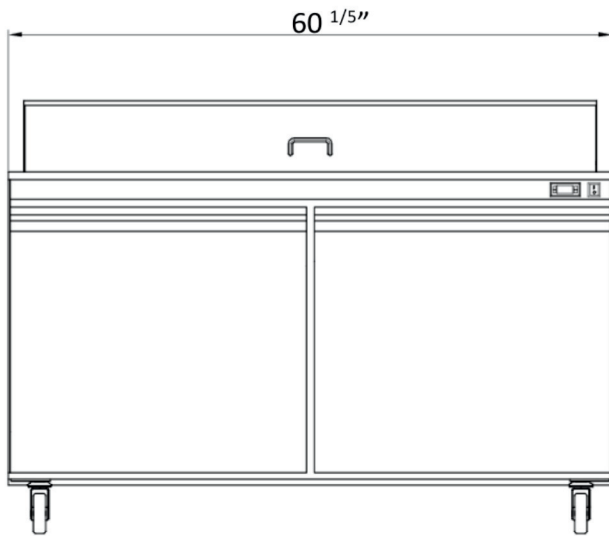



Notes & Details

1. **Compact Design:** With a height of 46 4/8 inches with the lid open, this prep table is designed to fit in tight spaces while still providing ample storage and work surface.
2. **Flexible Pan Capacity:** It can hold up to 6 pans of 1/6 size and 2 pans of 1/9 size, allowing for versatile ingredient storage and organization.
3. **Durable Construction:** Made of stainless steel and aluminum, this prep table is durable, resistant to corrosion, and easy to clean, ensuring long-term reliability in a busy kitchen environment.
4. **Convenient Access:** The door access type is swing with a hinge on the right side, providing easy access to stored ingredients and supplies.
5. **Temperature Control:** The refrigeration type is air-cooled with a temperature range of 33 - 41 degrees Fahrenheit, ideal for keeping ingredients fresh and at the desired temperature.
6. **Compressor Location:** The compressor is rear-mounted with a side/rear breathing style, optimizing space and airflow for efficient cooling performance.
7. **Mobility:** Equipped with casters, this prep table can be easily moved and positioned as needed for cleaning or rearranging in the kitchen.
8. **Safety and Compliance:** The plug type is NEMA 5-15P, and the refrigerant type is R290, meeting safety standards and regulations for commercial refrigeration equipment.
9. **Capacity and Organization:** With a capacity of 15 cubic feet, it offers enough space to store ingredients for sandwich and salad preparation, while the individual shelf capacity of 88 lbs ensures sturdy support for heavy items.

Overall, this sandwich and salad prep table combines functionality, durability, and energy efficiency, making it a practical and reliable choice for commercial kitchens and food service establishments.

ETL Sanitation



Intertek

This product has been certified by ETL, a division of the Intertek Group, to meet applicable sanitation standards required for use in the United States and Canada.

5-15P



5-15P

This unit comes with a NEMA 5-15P plug

ETL, US



Intertek

This product has been certified by ETL, a division of the Intertek Group, to meet applicable electrical product safety standards required for use in the United States.