

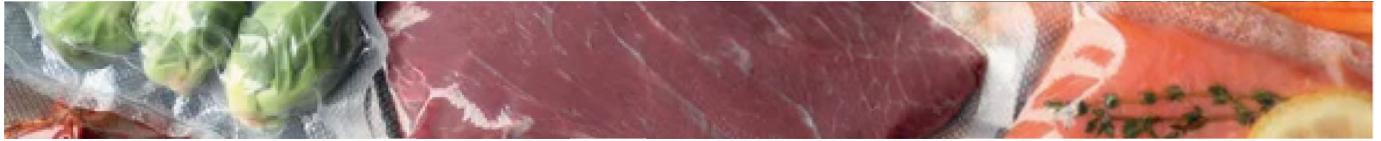

YOU CAN TRUST

## SEALING MACHINES

IBSF-300 / IBSF-450 / IBSF-600



**IBSF-300**  
12" IMPULSE BAG SEALER  
FOOT-OPERATED



**IBSF-450**  
18" IMPULSE BAG SEALER  
FOOT-OPERATED



**IBSF-600**  
24" IMPULSE BAG SEALER  
FOOT-OPERATED

### STANDARD FEATURES

Skyfood Foot-Operated Impulse Bag Sealers are available in different sizes, 12, 18 and 24" long seal bar to better suit your needs. Robust metal construction, these foot-operated bag sealers are essential tools in any food service and other commercial operations. Sealing food products helps protect them from getting stale or rotten, avoiding waste and increasing profit for your business. Ready to use, our Bag Sealers require no warm up time. Adjustable timer creates perfect seals for bags up to 12 mil thick. For use with PP (polypropylene) and PE (polyethylene) bags.

- Foot pedal operation
- Instantly use, no warm up time needed
- 7 timer settings to seal bags up to 12 mil thick
- Seal PP (polypropylene) and PE (polyethylene) bags
- On and Timer light indicators
- Include an adjustable worktable
- Easy to use and to clean
- Service kit available

ILLUSTRATIVE PHOTO, ACTUAL PRODUCTS AND ACCESSORIES ARE SUBJECT TO CHANGE WITHOUT NOTICE.



**Skyfood Equipment LLC**  
175 SW 7th Street, Ste 2416  
Miami, FL 33130

**Toll Free:**  
1-800-503-7534  
sales@skyfood.us

[www.skyfood.us](http://www.skyfood.us)



Follow us to keep up to date with the latest news and offers

/SkyfoodEquipment

/SkyfoodEquipment

/SkyfoodEquipment



YOU CAN TRUST

## SEALING MACHINES

IBSF-300 / IBSF-450 / IBSF-600

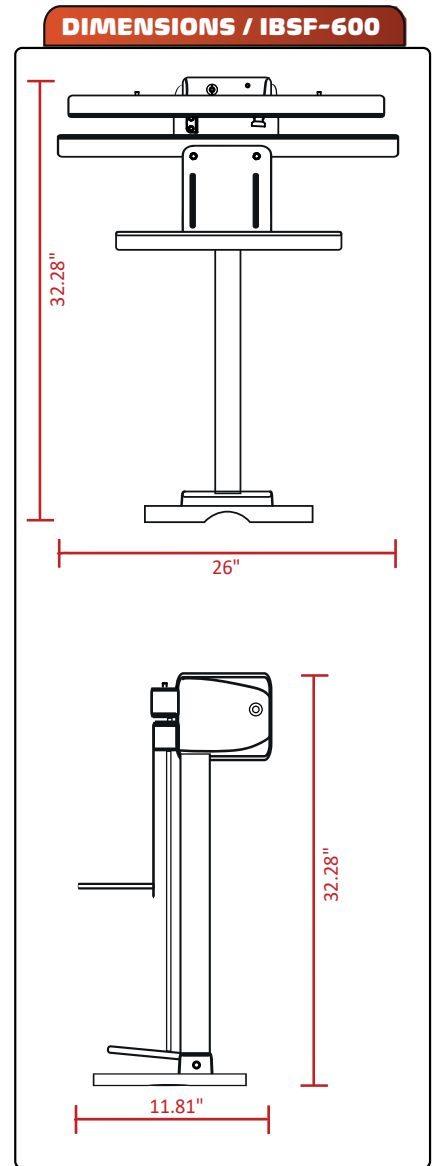
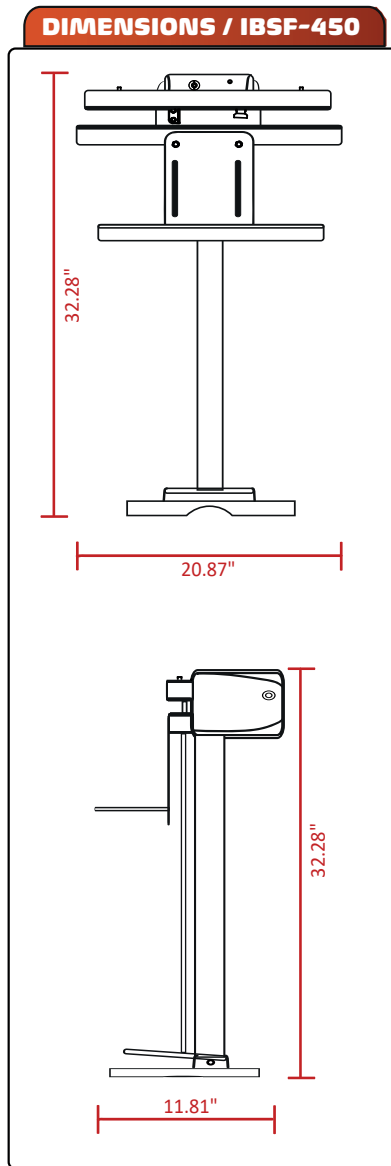
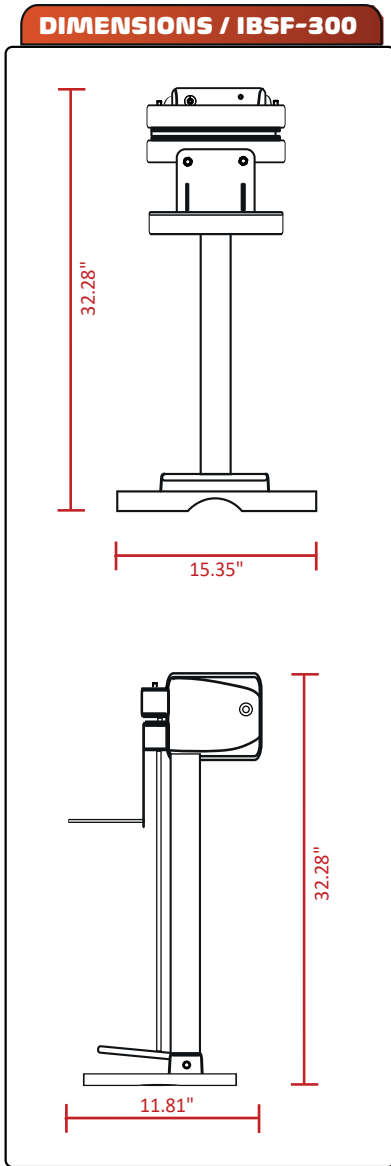

**WARRANTY 01 YEAR PARTS AND LABOR  
VALID IN THE CONTINENTAL UNITED STATES.**

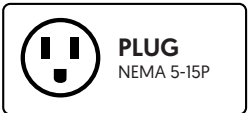

**ASSEMBLY REQUIRED**  
ASSEMBLY INSTRUCTIONS  
PROVIDED WITH MACHINE.

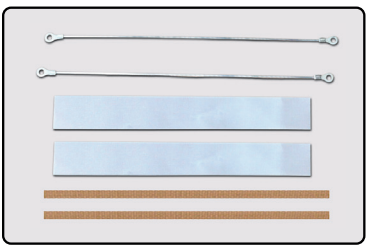

**ELEMENT SERVICE KIT**  
INCLUDES  
2 HEATING ELEMENTS  
2 PTFE STRIPS  
2 PTFE COVERS

**MADE IN TAIWAN**

Item	Voltage	Power Rating	Amps	Dimensions (W x D x H)	Weight (Net x Ship)	Seal Bar	Max. Bag Thickness	PLUG
IBSF-300	110/220 V	600 W	5.5	15.35" x 11.81" x 32.28"	37.5 lb x 39 lb	11.8" long x 1/16" (2 mm) wide	12 MIL (0.3mm)	NEMA 5-15P
IBSF-450	110/220 V	700 W	6.5	20.87" x 11.81" x 32.28"	44.1 lb x 46 lb	17.7" long x 1/16" (2 mm) wide	12 MIL (0.3mm)	NEMA 5-15P
IBSF-600	110/220 V	660 W	6	26" x 11.81" x 32.28"	48.5 lb x 49 lb	23.6" long x 1/16" (2 mm) wide	12 MIL (0.3mm)	NEMA 5-15P



**Skyfood Equipment LLC**  
175 SW 7th Street, Ste 2416  
Miami, FL 33130

**Toll Free:**  
1-800-503-7534  
sales@skyfood.us

[www.skyfood.us](http://www.skyfood.us)



ILLUSTRATIVE PHOTO, ACTUAL PRODUCTS AND ACCESSORIES ARE SUBJECT TO CHANGE WITHOUT NOTICE.