

CSP SERIES / STOCK POT STOVE



■ **CSP-18-3S
SHORT BODY**



■ **CSP-18-3 STANDARD BODY**



■ **CSP-2-18-3 DEEP BODY
FRONT/BACK BURNERS**

✓ **180,000 BTU**

✓ **90,000 BTU**
#304 Stainless Steel Legs

✓ **Welded #304 Stainless Steel**
For easy cleaning and long life



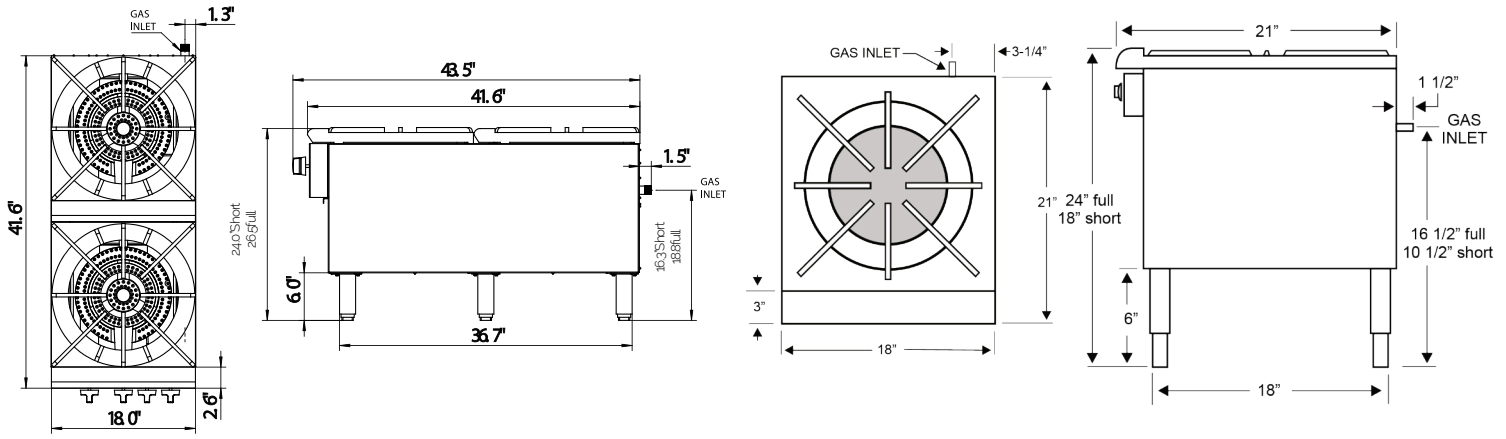





▶ **Available Options**
• **Stainless Steel Wok Adapter Ring**



MODEL	WIDTH	DEPTH	HEIGHT	BTU	Flame Ring	WT. (EST)*
CSP-18-3	18"	20-1/2"	24"	90,000	3-ring	105
CSP-18-3S	18"	20-1/2"	18"	90,000	3-ring	100
CSP-2-18-3	18"	43-1/2"	24"	180,000	3-ring each	195

*Note: Weight estimates are uncrated

▶ PRODUCT SPECIFICATIONS:

 BODY 18 Gauge #304 Stainless Steel, Fully Welded	 FRONT Removable 18 Gauge #304 Stainless Steel Panel	 GRATE Heavy Duty Painted Cast Iron w/ "Center-Slope" Hole	 BURNERS 3-ring 90,000 BTU in total Heavy Duty Painted Cast Iron	 DRIP PAN 18 Gauge #304 Stainless Steel
 VALVES Heavy Duty Brass	 GAS INLET 3/4 NPT	 GAS PRESSURE 4.0" Natural, 10.0" Propane (Inches Water Column)	 LEGS (FLOOR MODEL) 1-5/8" rd. X 16 Gauge #304 Stainless Steel tubing with Stainless Steel undershelf and adjustable feet.	

▶ NOTES:

Gas Pressure Regulator is supplied and must be installed
 Non-Combustible Locations Only:

- 0" Clearance sides and back
- Specify type of gas and altitude if over 2,000 feet

 Connerton reserves the right, without notice, to make changes and revisions in product specifications, materials and design, which in our opinion will provide better performance, durability and efficiency.