

INSULATED STAINLESS STEEL ROLL-IN OVEN WITH RACK MODEL RR-1332-D

FEATURES AND BENEFITS:

- Roll-In Rack designed for moving school prepackaged meals in baskets from prep area, central kitchen, commissary or cooler into oven.
- Roast, cook, bake, rethermalize and hold with precise temperature and humidity control. Power boosting switch allows end user flexibility to increase or reduce air flow.
- 18,000 or 12,000 Watts of power allows for rethermalization of prepared meals or bulk items. Maximum temperature 350°F. (176.5°C.).
- Standard solid state electronic control with large, clean, easy-to-read and operate LED digital display to ensure holding at precise food temperatures.
- Non-venting oven, permitted by most local codes, provides easy, inexpensive installation.
- Stainless steel construction and smooth interior covered corners for ease of cleaning and to prevent food particle/grease buildup.
- High temperature ceramic magnetic latch for “easy open” and silicone door gasket for proper seal.
- Safety conscious anti-microbial latch protects against spreading germs. Standard with right hand hinging; left hand hinging available upon request.



RR-1332-D

Standard (-DE)



All Ovens come standard with easy-to-read and operate LED digital controls.

Deluxe (-DX)



Deluxe Controls are available with 18 programmable menus and 3" food probe.

POWER UNIT OPTIONS:

- 18,000 Watts, 208 Volts, 3 Phase, 60 Hz.
- 18,000 Watts, 480 Volts, 3 Phase, 60 Hz.
- 12,000 Watts, 208 Volts, 3 Phase, 60 Hz.
- 12,000 Watts, 208 Volts, 3 Phase, 60 Hz.
- 8,000 Watts, 208 Volts, 1 Phase, 60 Hz.

Deluxe Models (-DX) have 18 factory or field programmed cook & hold cycles. Each programmed menu can be customized for exact time and temperature needs. Probe cooking includes one 3" food temperature probe and port.

ACCESSORIES and OPTIONS (Available at extra cost):

- Deluxe version with 18 programmable menus and 6" meat probe (or optional 3" food probe)
- Security Panel for Controls
- Key Lock Latch
- Wire Baskets
- Extra Roll-In Rack



RR-1332-D

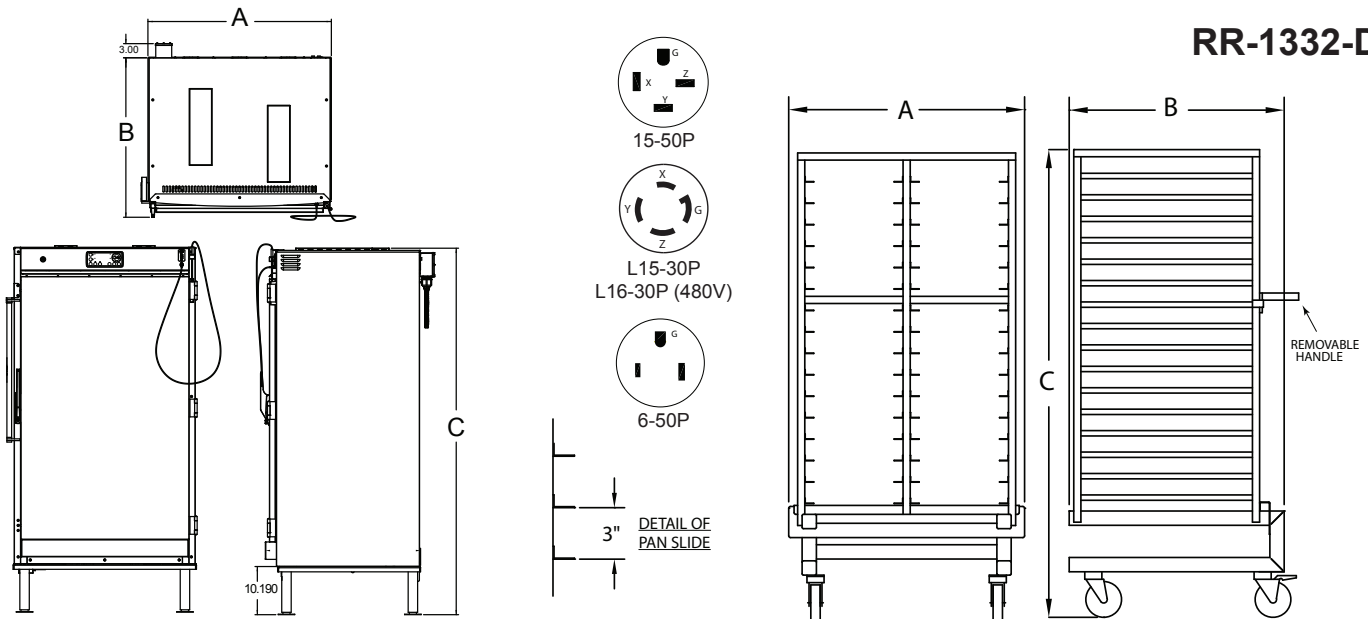

CRES COR MODEL NO.	CAPACITY / SIZE		DIM "A"	DIM "B"	DIM "C"	INSIDE DIMENSIONS			WEIGHT ACT.		
			WIDTH	DEPTH	HEIGHT	WIDTH	DEPTH	HEIGHT			
RR-1332-DE RR-1332-DX	1 RACK	IN	39	33-7/8	77-5/8	32-1/8	28-3/8	56-1/4	LBS	387	
		MM	991	859	197	816	721	1429	KG	176	
ROR-201-SBS-1332-D	32 BASKETS	13 X 26	IN	35-5/8	30-1/4	65-1/2	13-5/8	26	49-1/2	LBS	131
		330 X 660	MM	905	768	1663	346	660	1257	KG	59

INSIDE RACK WIDTH DIMENSION IS FOR ONE SIDE.

CABINET:

- Body: 22 ga. stainless steel.
- Inner liner: Formed 22 ga. stainless steel.
- Reinforcement: Internal framework of 14 ga. stainless steel channels, welded.
- Insulation: Fiberglass, thermal conductivity (K factor) is .23 at 75°F. 1-1/2" in back wall, door, base; 2" in side walls.
- Air tunnels: 20 ga. stainless steel, lift-out type, mounted on inner sides.

BASE:

- One piece construction, .190 aluminum.
- Legs: Heavy duty polished stainless steel 2" O.D. adjustable for leveling oven.

DOOR:

- Field reversible.
- Formed 22 ga. stainless steel.
- Latch: Chrome plated high pressure die cast zinc, composite handle, ceramic magnetic.
- Hinges: Heavy duty chrome plated die cast zinc, mounted inboard.
- Door Gaskets: Perimeter type, silicone.

ELECTRICAL COMPONENTS:

- Thermostat (retherm/hold): Solid state digital control, 140°F to 350°F (176.5°C).
- Switch: ON-OFF push button type.
- Power cord: Permanent, 8 ft., with:
 - Right angle straight blade plug for 50A., 3Ph.
 - Twistlock plug for 30A., 3Ph.
 - Right angle straight blade plug for 50A., 1Ph.
- Heaters (6): 2000 Watts each for 12KW; 3000 Watts each for 18KW.
- Switch: (1) Air volume.
- Blower motors: (6).
- Vent fans: (3).
- Fuses: (2) 6 Amp.

POWER REQUIREMENTS AVAILABLE:

- 18,000 Watts, 208 Volts, 3 Phase, 60 Hz., 50 Amp. Service
- 18,000 Watts, 480 Volts, 3 Phase, 60 Hz., 50 Amp. Service
- 12,000 Watts, 208 Volts, 3 Phase, 60 Hz., 50 Amp. Service
- 12,000 Watts, 480 Volts, 3 Phase, 60 Hz., 30 Amp. Service
- 8,000 Watts, 208 Volts, 1 Phase, 60 Hz, 50 Amp. Service

ROLL-IN RACK (ROR-201-SBS-1332-D):

- Angles (16 sets): Formed, permanently attached, spaced on 3" centers.
- 5" dia. swivel, modulus tires, 1-1/4" wide, load cap. 250 lbs. each, temp. range -45/+180°F. Delrin bearings. Two casters equipped with brakes.
- Capacity: 2 baskets side-by-side, 16 baskets high, 32 baskets total, 320 meals total.
- Total weight capacity for retherm: Maximum unit loading equals
- 150 lbs. equally distributed among 32 baskets at 4.66 lbs./basket, per Annex B in NSF Standard 4 "Performance Test Methods for Rethermalization Equipment".

NOTE: BASKETS NOT INCLUDED.

SHORT FORM SPECIFICATIONS

Cres Cor QuikTherm™ Roll-In Retherm Oven Model RR-1332-D. 18 ga. stainless steel, recessed control panel. Cabinet and Dutch doors 22 ga. stainless steel; stainless steel internal frame; coved corner interior. Fiberglass insulation in sides 2"; back, doors and base 1-1/2". High temperature anti-microbial magnetic latches. One piece base .190 aluminum. 2" dia. stainless steel legs. Includes Cres Cor Roll-In Rack Model ROR-201-SBS-1332-D: 16 angles on 3" centers; holds 32 baskets. 5" swivel modulus casters, Delrin bearings. Load capacity 250 lbs. each, temperature -45 to +180°F. 120 Volts, 60 Hz., 1 Phase. 2 year parts warranty. Provide the following accessories: _____. CSA-US, CSA-C, CSA to NSF4 listed.

In line with its policy to continually improve its products, CRES COR reserves the right to change materials and specifications without notice.



5925 Heisley Road • Mentor, OH 44060-1833
Phone: 877/CRES COR • Fax: 440/350-7267
www.crescor.com

© Crescent Metal Products, Inc. 2016 All rights reserved.

Litho in U.S.A.