

Front-Venting Refrigerators

- Create a seamless, built-in look that adds a clean, professional appearance, ideal for open kitchens or customer-facing areas.
- Ensure efficient operation in high-traffic areas by directing heat away from the interior, maintaining consistent airflow even in compact spaces.
- Unidirectional casters included for easy maneuverability and stability in tight spaces.



UCRE327-SS11A



UCRE332-SS11A

Model	Description	Voltage/Hz/Phase/Amps	Shipping Weight
UCRE327-SS11A	27" Front-Venting 1 Door Refrigerator	115 / 60 / 1 / 3.4	221 lb
UCRE332-SS11A	32" Front-Venting 1 Door Refrigerator	115 / 60 / 1 / 3.4	242 lb

Specifications
UCRE327-SS11A dimensions: 33 31/32" H x 27 21/32" W x 31 3/4" D
UCRE332-SS11A dimensions: 33 31/32" H X 32 9/32" W X 31 13/16" D
UCRE327-SS11A: volume of 6.39 cu ft, 1 epoxy coated shelf
UCRE332-SS11A: volume of 8 cu ft, 1 epoxy coated shelf
AISI 304 stainless steel interior and exterior
Autodefrost
CFC-free high density polyurethane insulated cabinet
Electronic Control
Environmentally friendly R290 refrigerant
Epoxy coated, sealed evaporator eliminates potential corrosion
Factory pre-wired for dedicated outlet, 11 ft cord and plug included NEMA 5-15P
NSF/ANSI Standard 7 compliant
Temperature range: 28°F to 46°F

Front (UCRE327-SS11A)

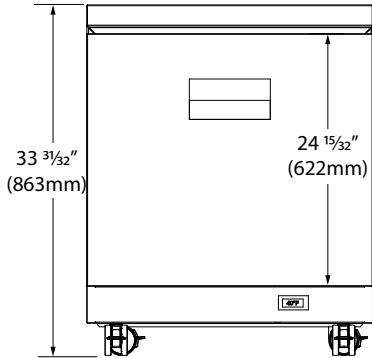

Top

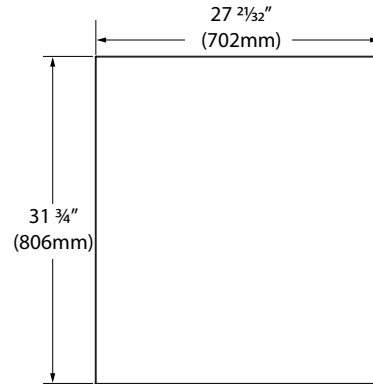

Front (UCRE332-SS11A)

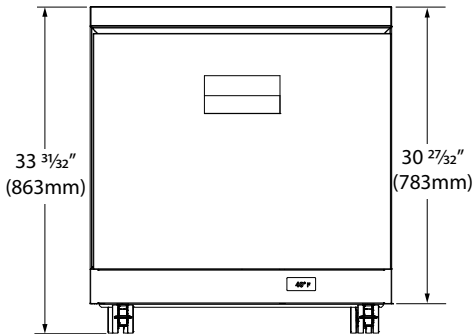

Top

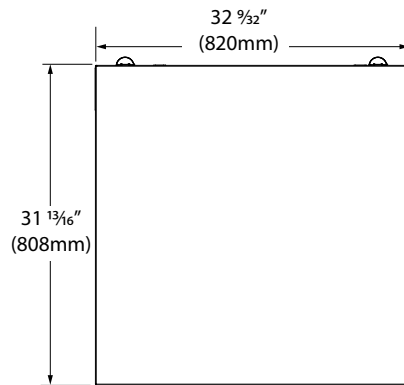

Side (all models)

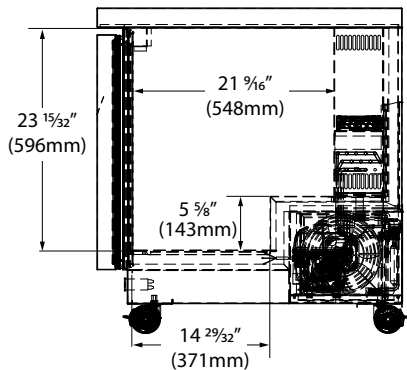

Commercial Warranty

3 Year (parts & labor) / 5 year sealed system (parts)
See complete warranty for details