



# BEVERAGE-AIR®

Project: _____	AIA#
Item: _____	
Location: _____	SIS#
Approved: _____	

**SMF49HC SINGLE ACCESS, FORCED AIR: SCHOOL MILK SERIES**

## SCHOOL MILK FORCED AIR COOLER

SMF49HC Single Access Cooler  
Hydrocarbon Series

**MODEL:**  
**SMF49HC-1-W-02**



**7 Year Parts/Labor Warranty**  
**7 Year Compressor Warranty**

### CABINET CONSTRUCTION

- White coated steel exterior
- Stainless steel interior
- Stainless steel lids, hinged door and door latches
- Full electronic control
- Heavy-duty epoxy coated steel wire floor racks standard
- Floor drain is centrally located for easy cleaning, connecting to drain hose with hose adapter
- Flexible compression door gaskets, ensures a tight seal
- Self-latching doors/lids with safety bumpers
- Exterior thermometer
- Cylinder lock
- 6" Heavy-duty plate casters (2 with locks)
- Balanced, forced-air refrigeration system provides rapid chilling of product

### OPTIONS & ACCESSORIES

- Corner bumpers
- Cafeteria tray slides
- Graphics

### REFRIGERATION SYSTEM

- Uses environmentally friendly, energy efficient R290 refrigerant, and meets all regulatory requirements for CARB, SNAP, DOE & more
- Maintains product temperature between 36°F to 40°F



  
Please verify qualifying units by visiting:  
[www.energystar.gov/cfs](http://www.energystar.gov/cfs)

3779 Champion Blvd., Winston-Salem, NC 27105  
1-888-845-9800 Fax: 1-336-245-6453  
Beverage-Air.com Sales@bevair.com



# BEVERAGE-AIR

## School Milk Cooler - Single Access

Model: SMF49HC-1-W-02

MODEL	SMF49HC-1-W-02
<b>EXTERNAL DIMENSIONAL DATA</b>	
Width Overall (in)	49"
Depth Overall (in)	33 5/8"
Height Overall with Casters (in)	47"
Number of Lids/Doors	Single Access
Depth with Door Open 90° (in)	48 1/2"
<b>INTERNAL DIMENSIONAL DATA</b>	
NET Capacity (cubic ft.)	19.66
Internal Width Overall (in)	46"
Internal Depth Overall (in)	30"
Internal Height Overall (in)	24 7/8"
<b>CASE CAPACITY</b>	
13" X 13" X 11"	12
19" X 13" X 11"	8
<b>ELECTRICAL DATA</b>	
Full Load Amperes	2.46
<b>REFRIGERATION DATA</b>	
Horsepower	1/4
Capacity (BTU/Hr)	1851
Heat Rejection (BTU/Hr)	2776.5
Charge (lbs/grams/ounces)	0.1562 / 70.8 / 2.5
<b>SHIPPING DATA</b>	
Gross Weight - Crated	437 lbs
Height - Crated	54"
Width - Crated	54"
Depth - Crated	38"

We reserve the right to change specifications and product design without notice. Such revisions do not entitle the buyer to corresponding changes, improvements, additions or replacements for previously purchased equipment. Dimensional tolerances +/- 1/4". Metric dimensions (MM).

### Model Views

Required Clearance: 4 3/8" bottom

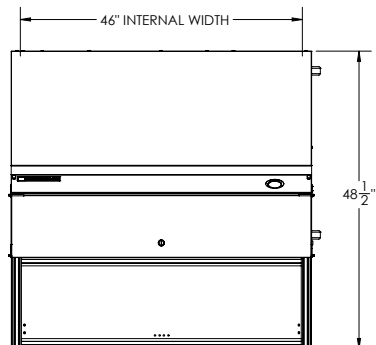

### PLAN VIEW

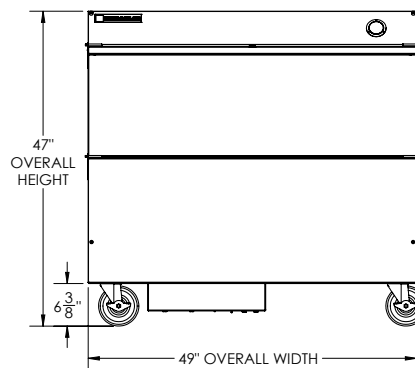

### ELEVATION VIEW

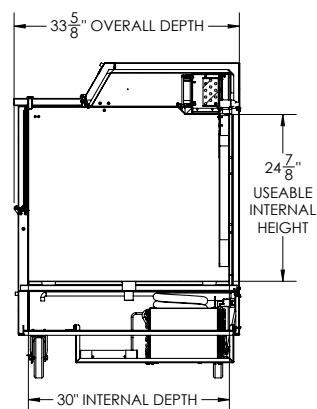

### SIDE VIEW

### ELECTRICAL CONNECTION



115/60/1  
NEMA 5-15P

Unit pre-wired at factory and include 8' long cord and plug set.

