

**Refrigeration Equipment
1-Glass Door Full Height Reach-In
Back Room Refrigerator 31" Long**

ITEM # _____

MODEL # _____

NAME # _____

SIS # _____

AIA # _____



738283 (KCHRI25R1GDR) 1-Glass Door Full Height Reach-In Back Room Refrigerator 31" Long

Short Form Specification

Item No. _____

1 glass door refrigerator with exterior back and bottom panels in galvanized steel, exterior side and top panels in prepainted steel; interior back, side, top and bottom panels in white High Impact Polystyrene. Control with cabinet temperature display. Self-closing door feature with lock and key. R290 gas in the refrigeration circuit. ETL Safety and Sanitation certifications. 3/5 Years warranty.

Main Features

- External digital temperature display.
- Removable gasket for easy cleaning operations.
- Fin & Tube Condenser improves performance in high temperature environments.
- Automatic Defrost Cooling System provides worry-free performance.
- Electronic Temperature Control, quick and simple to set, with control display for easy monitoring.
- Cabinet completely insulated with high density polyurethane for low environmental impact.
- Back bottom mounted cooling unit guarantee an easy access and cleaning.

Construction

- Lockable door.
- Pre-wired heavy duty power cord.
- Heavy duty door hinges.
- Magnetic gasket removable without tools for easy cleaning.
- PVC shelves.

Sustainability

- CFC and HCFC free, highly ecological refrigerant type: R290 (ecological gas in foam: cyclopentane). Hydrocarbon refrigerant gas R290 for the lowest environmental impact (GWP=3), to reduce green house and ozone depletion effects.
- High efficiency components to minimize the energy consumption still guaranteeing the highest performances.
- Hydrocarbon refrigerant gas R290 for the lowest environmental impact (GWP=3) - CFC and HCFC free.

Optional Accessories

- Shelf clips (4-pack) PNC 880611
- Shelf for 25" Reach-In PNC 880678

APPROVAL: _____

Front

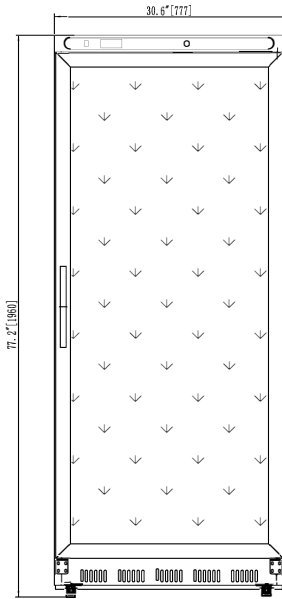

Side

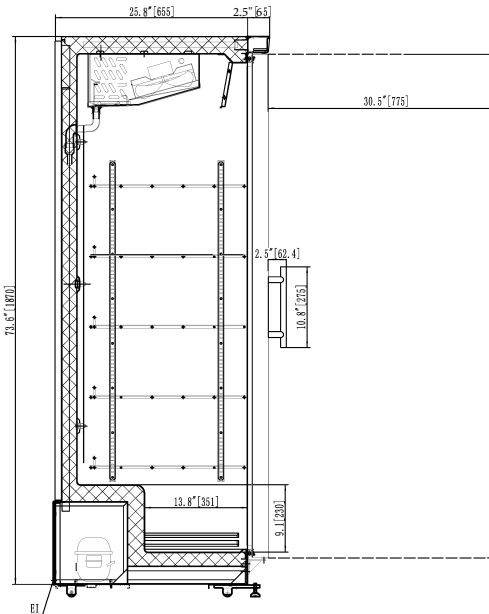

EI = Electrical connection

Top

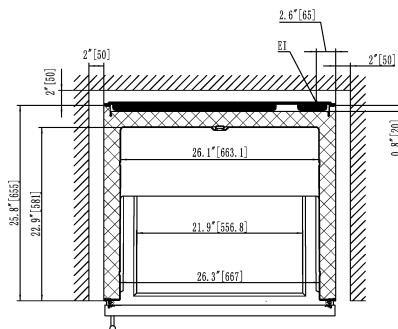

Electric

Supply voltage:	115 V/1 ph/60 Hz
Electrical power, max:	2.07 kW
Plug type:	USA NEMA 5-15P

Capacity:

Gross capacity:	22.7 cu.feet
-----------------	--------------

Key Information:

Door hinges:	Right Side
External dimensions, Width:	30 9/16" (777 mm)
External dimensions, Depth:	28 3/8" (720 mm)
External dimensions, Height:	77 3/16" (1960 mm)
Number and type of doors:	1 Glass
Internal Dimensions (depth):	22 3/4" (578 mm)
Internal Dimensions (height):	65 3/8" (1660 mm)
Internal Dimensions (width):	26 3/8" (670 mm)
Shipping height:	82 11/16" (2100 mm)
Shipping weight:	324 lbs (147 kg)
Number and type of grids (included):	3 - Vinyl-Coated steel
Type of external material:	Prepainted Steel
Type of internal material:	High Impact White Polystyrene
Warranty:	3 / 5 years
Approvals	ETL C&US;ETL SANITATION

Refrigeration Data

Condenser Type:	738283 (KCHRI25R1GDR)	Fin & Tube
Compressor power:		1/5 hp
Operating temperature min.:		32 °F
Operating temperature max.:		41 °F
Defrost type:		auto defrost

Sustainability

Current consumption:	3 Amps
Refrigerant type:	R290
GWP Index:	3

Refrigeration Equipment 1-Glass Door Full Height Reach-In Back Room Refrigerator 31" Long

The company reserves the right to make modifications to the products without prior notice. All information correct at time of printing.

