



BEVERAGE-AIR

Project: _____	AIA#
Item: _____	
Location: _____	SIS#
Approved: _____	

DD58HC DIRECT DRAW DISPENSER

DRAFT BEER EQUIPMENT-DIRECT DRAW DISPENSER

**MODEL:
DD58HC-1-B**

DD58HC Solid Door Dual Towers, One Single & One Dual Faucets
Hydrocarbon Series



**7 Year Parts/Labor Warranty
7 Year Compressor Warranty**

CABINET CONSTRUCTION

- Exterior features durable black painted steel with galvanized steel back
- Top and drip trays are heavy-duty stainless steel
- Interior is galvanized steel on walls and ceiling, reinforced floor and doorsills are heavy-duty stainless steel
- Full electronic control
- Dual towers, one (1) with single faucet and (1) with dual faucets
- 3-in-1 Draft solution uses a single stainless-steel tap to serve different beverages, such as wine, beer, and coffee (or other non-alcoholic beverages) through silver-lined, anti-microbial tubing that is 100% effective against the top 4 beverage spoiling bacteria
- 3" Stainless steel insulated dispensing tower
- Drain tube located at bottom front of cooler for connection to floor drain
- Door locks
- Self-closing doors with 120° stay-open feature
- Magnetic gaskets provide positive door seal
- Field reversible doors (hinge kit not included)
- Compressor available on left or right, specify at time of unit order

OPTIONS & ACCESSORIES

- Club top
- Stainless steel interior lining
- Stainless steel back
- Glass door
- Shelves
- Shelf clips
- Custom tower hole location
- Drip tray location option
- Wine models
- Faucet locks
- Glass rinser
- Right or left hinged door
- 2"- 3" Casters or 6" black legs
- 1- 6 Tap tower
- 2, 3 & 4 way manifolds
- Dual tap placement option
- No draft/hole cover option
- Remote option* (see note on back on page)

REFRIGERATION SYSTEM

- Refrigeration system uses R290 refrigerant to comply with all environmental concerns
- Automatic, non-electric defrost
- Epoxy coated evaporator coil
- Maintains product temperatures between 36°F and 38°F



Please verify qualifying units by visiting:
www.energystar.gov/cfs

3779 Champion Blvd., Winston-Salem, NC 27105
1-888-845-9800 Fax: 1-336-245-6453
Beverage-Air.com Sales@bevair.com



BEVERAGE-AIR®

Bar Equipment-Direct Draw Beer Dispenser Model: DD58HC-1-B

MODEL	DD58HC-1-B
EXTERNAL DIMENSIONAL DATA	
Width Overall	59"
Depth Overall	29"
Height Overall (floor to top of tap)	52 1/2"
Number of Doors	2
Depth with Door Open 90°	50 1/2"
Door Openings (in)	21" x 30"
INTERNAL DIMENSIONAL DATA	
NET Capacity (cubic ft.)	21.86
Internal Width Useable (in)	46 1/8"
Internal Depth Overall (in)	23 1/8"
Internal Height Overall (in)	27 3/8"
Number of 1/2 Kegs	3
ELECTRICAL DATA	
Full Load Amperes	2.5
REFRIGERATION DATA	
Horsepower	1/4
Capacity (BTU/Hr)	1702
Heat Rejection (BTU/Hr)	2553
Charge (lbs/grams/ounces)	0.2094 / 95 / 3.35
SHIPPING DATA	
Gross Weight - Crated	342 lbs
Height - Crated	45"
Width - Crated	62"
Depth - Crated	32"

*NOTE: Remote units are field wired and come with 6" legs. Refrigerant must be specified at time of order.

We reserve the right to change specifications and product design without notice. Such revisions do not entitle the buyer to corresponding changes, improvements, additions or replacements for previously purchased equipment. Dimensional tolerances +/- 1/4". Metric dimensions (MM).

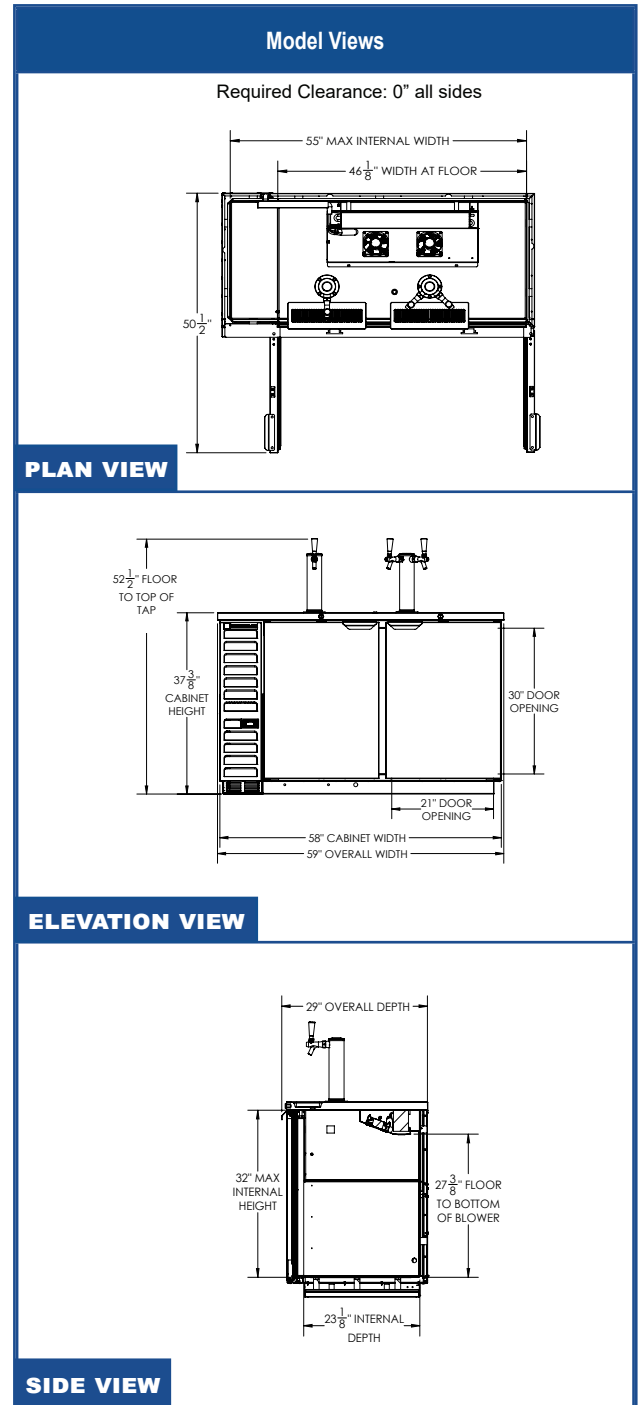
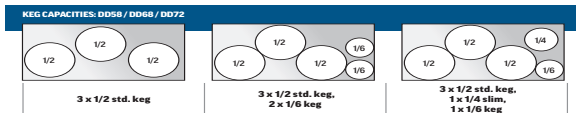

ELECTRICAL CONNECTION



115/60/1
NEMA 5-15P

Unit pre-wired at factory and include 8' long cord and plug set.

